

Propane Conversion Kit Instructions

For G124X SP/DP – Model Boilers

This kit and instructions are for converting the G124 X SP/DP– Model Boilers from Natural Gas to Propane.

REQUIRED INPUT RATES

G 124 X–18 74, 000 BTU/HR	G 124 X–25 103, 000 BTU/HR	G 124 X–32 132, 500 BTU/HR
------------------------------	-------------------------------	-------------------------------

WARNING

This conversion kit shall be installed by a qualified service agency in accordance with the manufacturer's instructions and all applicable codes and requirements of the authority having jurisdiction. If the information in these instructions is not followed exactly, a fire, explosion or production of carbon monoxide may result causing property damage, personal injury or loss of life. The qualified service agency performing this work assumes responsibility for the proper conversion of this appliance with this kit.

CAUTION: The gas supply shall be shut off prior to disconnecting the electrical power, before proceeding with the conversion.

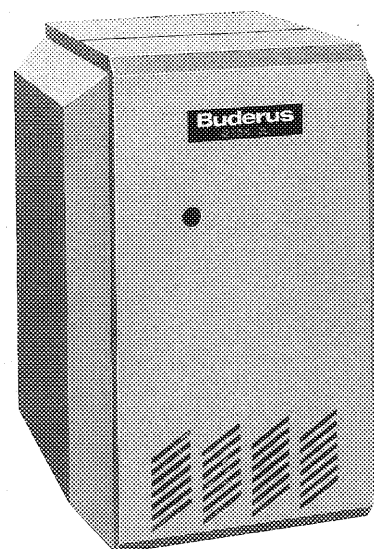

Notice: This manual must be retained for future reference!

Parts List for converting the boilers to propane

This kit contains the following parts.

- Honeywell gas valve conversion kit # 393 691 which includes:
 - black capscrew
 - pressure regulator adjusting screw
 - red spring
 - yellow label for gas control
- Pilot orifice GAF 8
- Main Gas Burner orifices and gaskets
- Label to be filled out and affixed to the appliance
- Instructions

TO CONVERT THE BOILER TO PROPANE, THE FOLLOWING INSTRUCTIONS SHALL BE ADHERED TO.

1. If the boiler has been in operation, shut off the main gas valve. If the boiler has not been placed into service, go to step 3.
2. Turn off all electric power to the appliance and set the thermostat to lowest setting.
3. Remove Control Access Panel from the boiler, fig. 1

Turn the gas control manual valve clockwise ↻ to the full "OFF" position, fig. 2.

Wait five (5) minutes to clear out any gas. Then smell for gas, including near the floor. If you smell gas, **STOP!** Follow "B" in the safety information printed on page 5. If you do not smell gas, go to the next step.

4. Disconnect the pilot line from the gas control, fig.3.
5. Disconnect the thermocouple from the gas valve, fig. 3

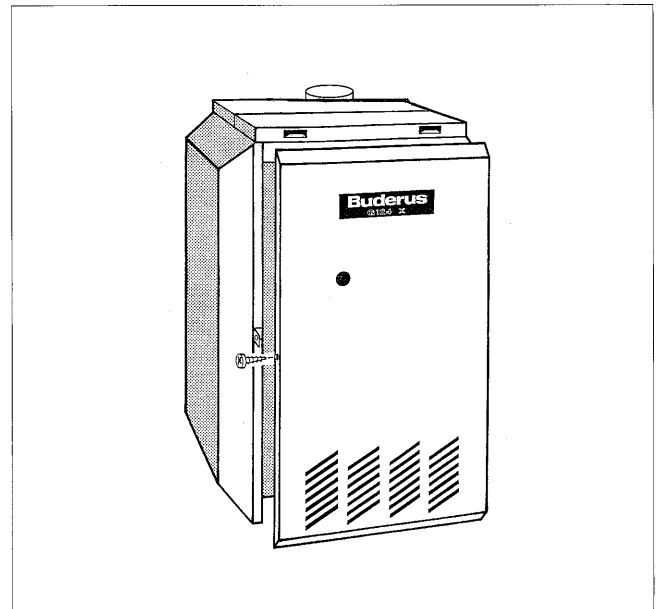

Fig.1

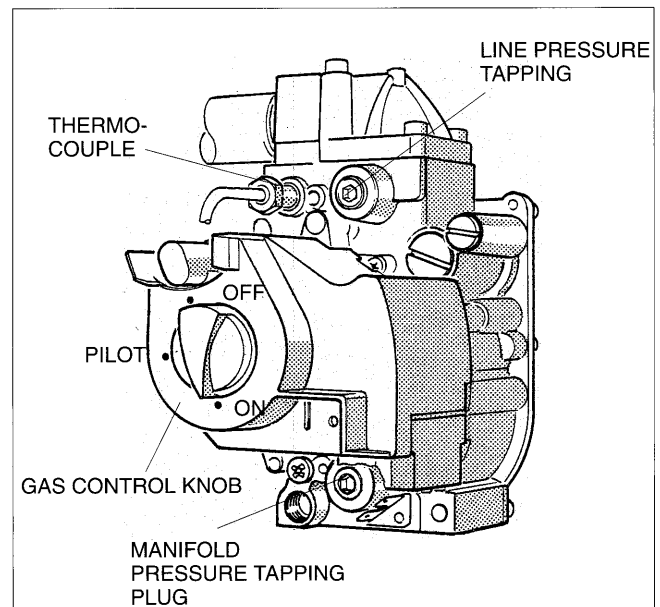

Fig.2

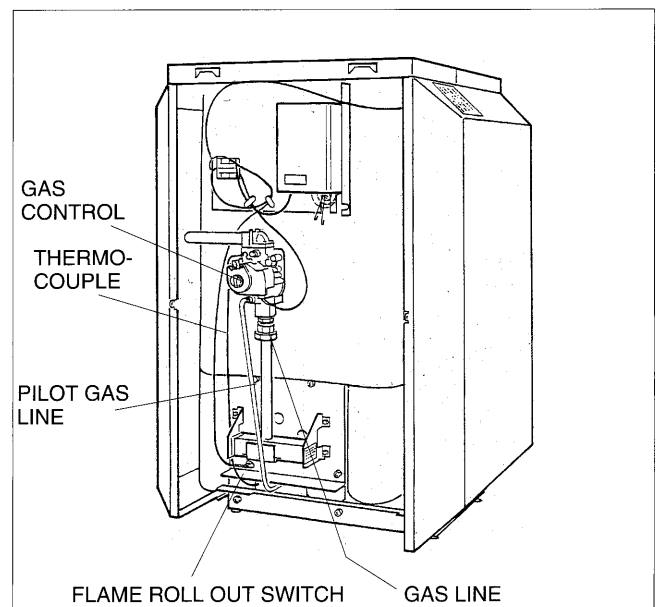



Fig.3

6. Remove the pressure regulator capscrew from the gas control, fig.4.
7. Remove the pressure regulator adjusting screw, fig.4.
8. Remove the stainless steel spring, fig.4.
9. Install the red spring contained in the Honeywell LP gas conversion kit into the gas control, fig.4.
10. Install the new pressure regulator adjusting screw. Install the adjusting screw flush with top of regulator.
Turn six (6) complete turns clockwise . This will supply a preliminary pressure of approximately 10.0 inches water column. The setting needs to be checked with a manometer after conversion of the manifold is completed.
11. Clean the gas control body and apply yellow label, shown below, to the gas valve so that is easily visible.

**ATTENTION
THIS VALVE HAS
BEEN CONVERTED
FOR USE WITH LP
GAS.**

12. Secure the gas supply piping to the slot in the top jacket panel with wire or rope.
13. Disconnect the union between the gas valve and the manifold. Place the gasket from the union in a safe place, fig. 3.

Caution: Label all wires prior to disconnecting when servicing controls. Wiring errors can cause improper and dangerous operation.

14. Label the flame roll-out switch wires and disconnect the wires from the flame roll-out switch, fig. 3.
15. Remove the 4 nuts and washers that secure the burner assembly to the boiler and remove the burner assembly from the boiler, fig. 3 and fig. 5.
16. Remove main gas orifices and washers from burner assembly fig. 5.
17. Install new orifices and washers supplied with kit. Ensure orifices are the proper size for your boiler application per the following table:

Propane Orifice Sizes			
Model	G124X-18	G124X-25	G124X-32
Orifice Size	1.80 mm	1.75 mm	1.70 mm
Quantity	2	3	4

Note :

These orifice sizes are for 0–2000 ft elevation only. For elevation 2001 ft–8000ft, see "Instructions for high altitude".

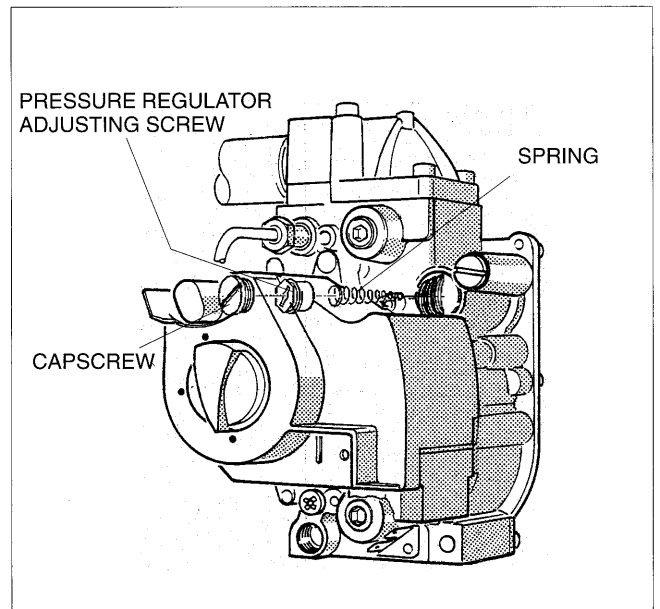

Fig.4

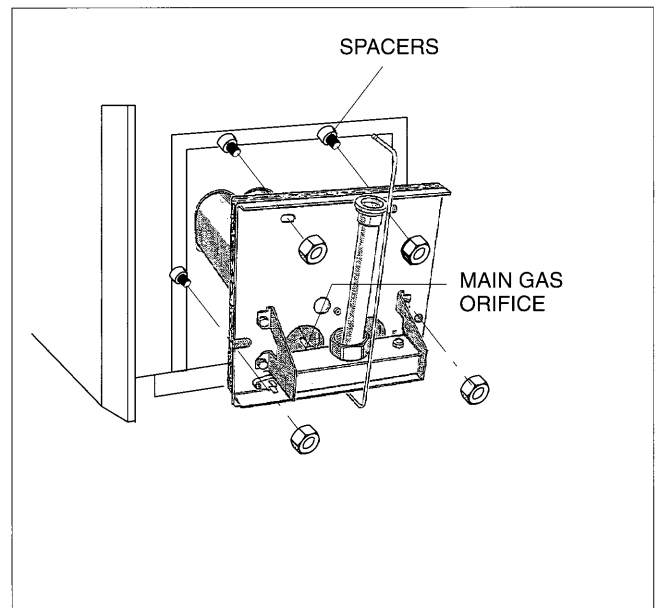

Fig.5

18. Disconnect the pilot gas line from the pilot assembly, fig. 6.
19. Remove pilot orifice.
20. Install new pilot orifice, GAF 8.
21. Install the pilot gas tubing in the pilot assembly.
22. Verify the pilot hood to main burner relationship shown in fig 6.
23. Install the burner assembly in the boiler in reverse order of removal. Ensure the spacers shown in fig. 5 are in place before installing the burner assembly in the boiler. Ensure the nuts are tightened firmly.
24. Reconnect the union between the gas valve and the manifold. Ensure that the gasket removed in step 13, is installed in the union.
25. Connect the flame roll – out switch wires to the flame roll–out switch.
26. Remove the wire or rope used to secure the gas supply piping in step 12.
27. Reconnect the pilot gas line to the gas valve, fig. 3.
28. Reconnect the thermocouple to the gas valve, fig. 3.
29. Fill out the required information on the conversion plate and affix the plate to the outside of the boiler jacket as close as possible to the existing rating plate.
30. If the boiler has not been placed into operation, follow the installation instructions in "**The Installation, Operation and Maintenance Manual**" supplied with the boiler. If the boiler has been in operation, then open the main gas shut–off valve. Test the gas piping on the input side of the gas control for leaks by applying a soap and water solution. If no leaks are found go to step 32. If any leaks are found, shut off the main gas piping shutoff valve.
31. Repair leaks and repeat step 30.
32. Shut off the main gas supply shut–off valve. Remove the line pressure tapping plug from gas control, fig. 2; install a test fitting, and hook up a manometer so that line pressure can be checked.
33. Remove the manifold pressure tapping plug from the gas control, install a test fitting and hook up a manometer so that manifold pressure can be checked, fig. 2.
34. Open the main gas piping shut–off valve and measure the supply pressure to the boiler. The supply pressure must be between 11 and 13 inches water column. If pressure is not between 11 and 13 inches water column, when boiler is running, call your service technician or gas supplier.
35. Follow the the lighting instructions next page.

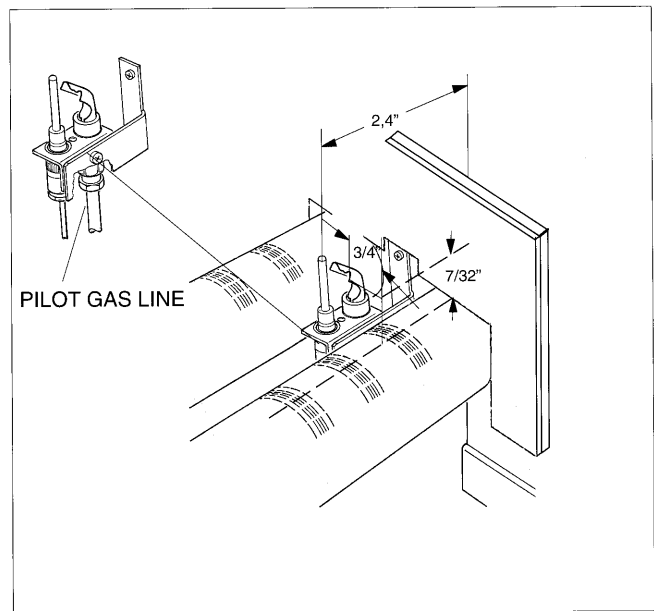

Fig.6: Pilot Assembly

Lighting Instructions

FOR YOUR SAFETY, READ BEFORE LIGHTING

WARNING: If you do not follow these instructions exactly, a fire or explosion may result causing property damage, personal injury or loss of life.

- A. This appliance has a pilot which must be lighted by hand. When lighting the pilot, follow these instructions exactly.
- B. **BEFORE LIGHTING** smell all around the appliance area for gas. Be sure to smell next to the floor because some gas is heavier than air and will settle on the floor.

WHAT TO DO IF YOU SMELL GAS

- Do not try to light any appliance.
 - Do not touch any electric switch, do not use any phone in your building.
 - Immediately call your gas supplier from a neighbor's phone. Follow the gas supplier's instructions.
 - If you cannot reach your gas supplier, call the Fire Department.
- C. Use only your hand to turn the gas control knob. Never use tools. If the knob will not turn by hand, don't try to repair it, call a qualified service technician. Force or attempted repair may result in a fire or explosion.
- D. Do not use this appliance if any part has been under water. Immediately call a qualified service technician to inspect the appliance and to replace any part of the control system and any gas control which has been under water.

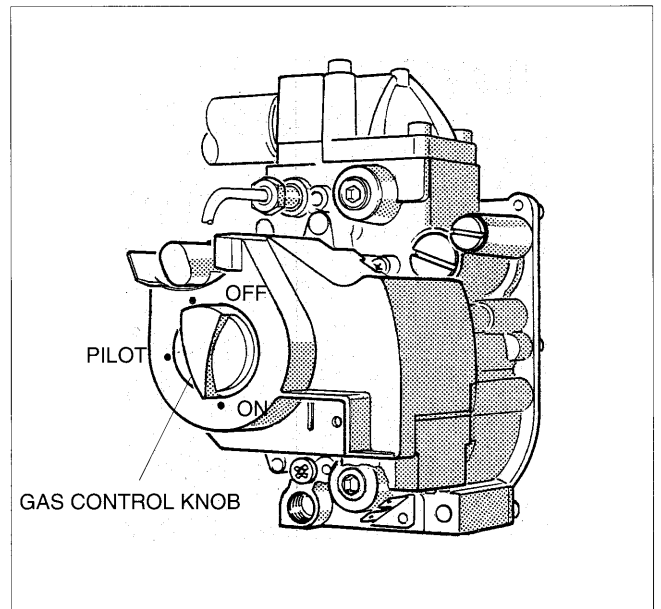





Fig.7

OPERATING INSTRUCTIONS

STOP! Read the safety information printed on page 5 in these instructions.



36. Wait five (5) minutes to clear out any gas. Then smell for gas, including near the floor. If you smell gas, **STOP!** Follow "B" in the safety information printed on page 5. If you do not smell gas, go to the next step.
37. Locate the pilot assembly by looking through the access hole in the burner assembly plate, fig.8.
38. Turn gas control knob counterclockwise  to "PILOT".
39. Push in red reset button all the way and hold in. Immediately light the pilot using the lighting rod provided, fig. 8 and a match. Continue to hold the red reset button in for about one (1) minute after the pilot is lit. Release the button and it should pop back up. Pilot should remain lit. If the pilot goes out, turn gas control knob clockwise  to "OFF", and repeat steps 36 through 39.

– If the button does not pop up when released, **stop.** Turn off main gas line shutoff valve, and immediately call your service technician or gas supplier.

– If the pilot will not stay lit after several tries, turn the gas control knob to clockwise  "OFF" and call your service technician or gas supplier.

40. Test pilot line for leaks with a soap solution. If no leaks are found go to step 42. If leaks are found, turn gas control knob clockwise  "OFF".

41. Repair leaks. Repeat steps 36 through 40.

42. Observe the pilot flame through hole in the burner assembly plate. The flame should envelop the thermocouple 3/8 – 1/2 inch, fig. 10. If the pilot flame is satisfactory then go to step 43. If the pilot flame is too small or too large, adjust the pilot using the pilot adjustment screw., fig. 9. Turn the inner adjustment screw clockwise  to decrease, or counterclockwise  to increase the pilot flame. After adjustment, replace the cover screw and tighten firmly.

43. Turn the gas control knob counterclockwise  to "ON". The knob can be turned to "ON" only if the red reset button is up.

44. Turn on all electric power to the appliance.

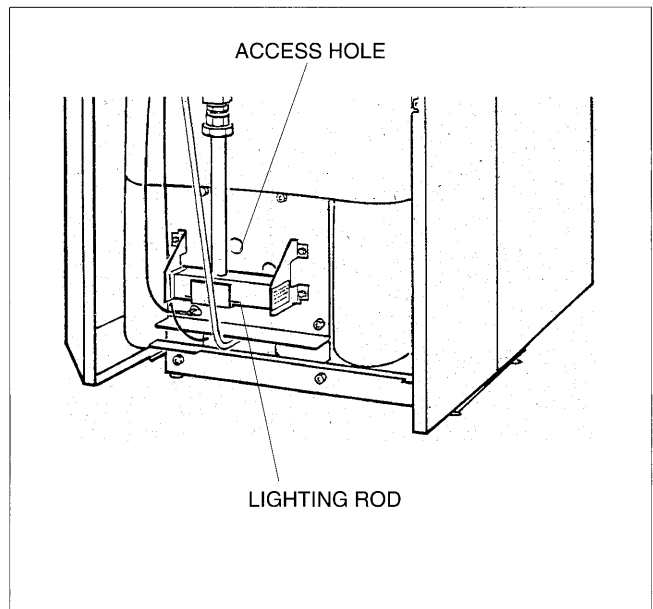

Fig.8

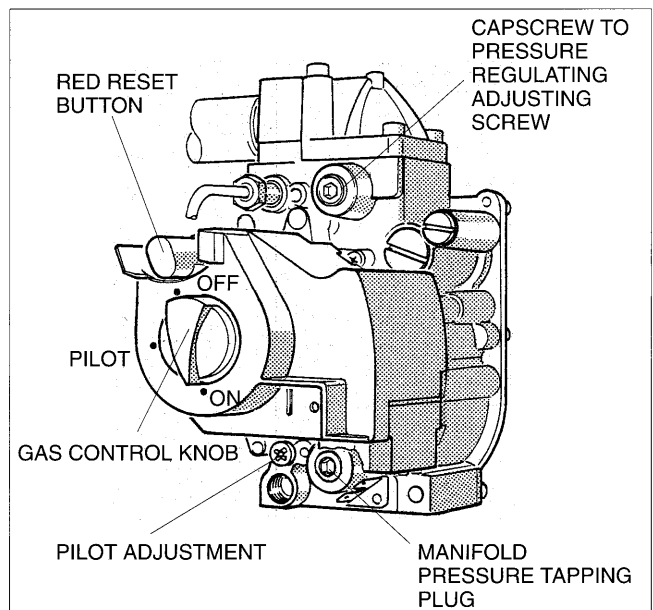

Fig.9

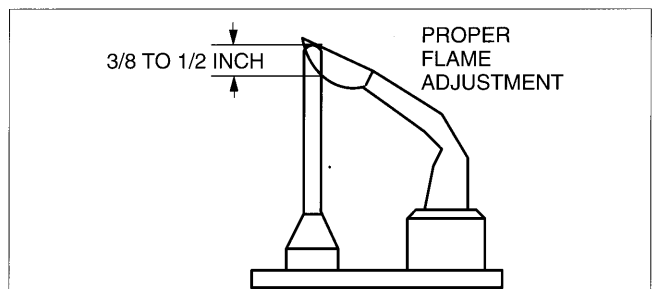

Fig.10

45. Ensure that there is a call for heat from the thermostat control.
46. The main burners should light at this time. If the main burners do not light, shut off the main gas piping shut-off valve, shut off all electric power to the appliance and call your service technician or gas supplier.
47. If the main burners light, then the gas fittings, union and orifices must be tested for leaks with a soap and water solution. If no leaks are found then go to step 49. If any leaks are found, turn gas control knob clockwise ↻ to "OFF". Turn off all electrical power to the appliance.
48. Repair leaks. Repeat steps 34 through 47.
49. The manifold pressure must be adjusted to the values shown in the table 4. To adjust the manifold pressure, remove the capscrew from the gas control, fig. 9. Turn the pressure regulating adjusting screw clockwise ↻ to increase, or counterclockwise ↺ to decrease the manifold pressure. This adjustment must be made while the boiler is in operation.
50. After adjustment, install the capscrew on the gas control, fig.9.
51. Observe the main burner flame through hole in the burner assembly plate. The flame should have a smooth, firm contour and be mostly blue in color, fig. 11. If the main burner flame is satisfactory, go to step 53. If main burner flame is lazy, yellow, or lifting off the burners, turn the gas control knob clockwise ↻ to "OFF". Shut off the main gas piping shut-off valve. Disconnect all electric power to the appliance and call your service technician or gas supplier.
52. Test the ignition safety shutoff means by turning the gas control knob clockwise ↻ to "OFF". The main burner and the pilot flame will extinguish. Turn the gas control knob counterclockwise ↺ to "PILOT". Wait three (3) minutes. Turn the gas control knob counterclockwise ↺ to "ON". There should be no gas flow to the main burners. Confirm zero (0) pressure on the manifold with manometer. If there is gas flow, immediately turn the gas control knob clockwise ↻ to "OFF". Shut off the main gas piping shutoff valve. Disconnect all electrical power to the appliance and call your service technician or gas supplier. If there is no gas flow, go to step 53.
53. Turn the gas control knob clockwise ↻ to "OFF".
54. Shut off the main gas piping shut-off valve.
55. Turn off electric power to the appliance.
56. Remove the pressure test fittings from the line pressure and manifold pressure taps in the gas control and replace the plugs.

57. Repeat steps 36 through 38, 43 through 46 and 51 to place the appliance back in operation. Check the plugs in the gas control with a soap and water solution. If no leaks are found go to step 59. If any leaks are found, shut off the main gas piping shut-off valve and turn the gas knob clockwise ↻ to "OFF". Turn off all electrical power to the appliance
58. Repair leaks. Open the main gas shut-off valve and repeat step 57.
59. Wash off the soap and water solution used to test for leaks to ensure no corrosive affects from the soap.
60. Replace the control access panel.

Model G124 X	Propane gas
18	9.8 Inches Water Column
25	10.3 Inches Water Column
32	10.0 Inches Water Column

Table 4: Required Manifold Pressure

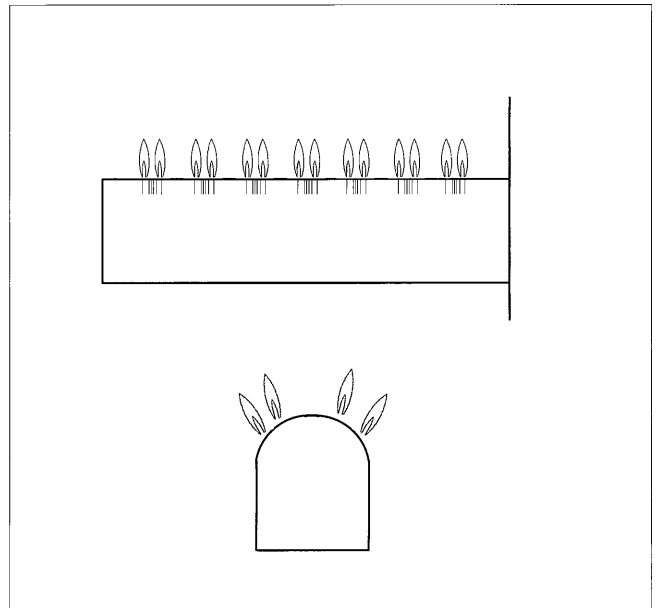

Fig. 11

Addresses

Installing contractor

Manufacturer:

Buderus Hydronic Systems, Inc.

16 Industrial Way

Salem, N.H. 03079

Phone: (603) 898-0506 Fax: (603) 898-1055

Subject to change without notice!

Printed in Germany