

Wall-mounted and floor-standing boilers

For heating contractors

Please read carefully prior to installation.



This product has been tested and is certified for both the US and Canadian markets and meets all applicable US and Canadian standards.

About these instructions

These instructions describe the installation options for the xM10 series of function modules for:

- wall-mounted boilers
- floor-standing boilers
- wall mounting

For boilers installed in non-standard situations, installation of the modules is described in the relevant boiler instructions.

Subject to technical modifications.

Constant development may lead to minor deviations in the illustrations, functional steps and specifications from those described/shown.

Updating your documentation

Please let us know if you have any suggestions which would improve our documentation or if you have noticed any errors.

1	Safety	4
1.1	Intended use	4
1.2	Please observe these notes.	5
1.3	Disposal.	5
2	Product description	6
3	Wall-mounted boilers	7
4	Floor-standing boilers12
5	Wall mounting17

1 Safety

This chapter contains general safety instructions, which you should observe when installing the xM10 function modules.

Severe personal injury and even death, as well as property damage, may follow if you ignore safety instructions.

1.1 Intended use

The xM10 function modules must only be used in combination with the energy management system (EMS) from Buderus.

The function module has protection class IP 40, which means that it must not be installed in any area where there is risk of water spray. The total length of the bus cable must not exceed 330 ft. (100m).

1.2 Please observe these notes



WARNING!

RISK OF LIFE

from electric shock.

- Always follow electrical code requirements when working on electrical installations.



PLEASE NOTE

Only use original Buderus spare parts. Damage caused by the use of spare parts not supplied by Buderus are excluded from the Buderus warranty.

1.3 Disposal

Dispose of defunct function modules in an environmentally responsible manner, through an approved organisation.

2 Product description

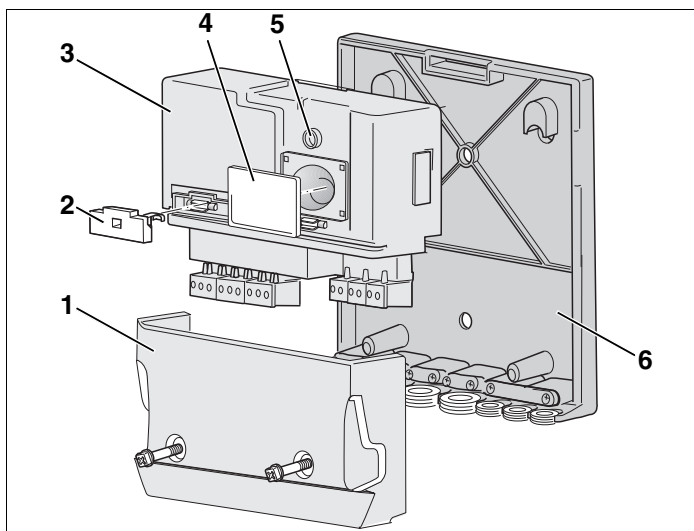

Fig. 1 xM10 function module (in this case wall-mounted)

Item 1: Terminal cover

Item 2: Fuse holder

Item 3: Function module

Item 4: Identification plate and access to the spare fuse and the dial (for MM10 only)

Item 5: Operation/fault LED

Item 6: Wall bracket



PLEASE NOTE

If you are installing the MM10, ensure that the dial behind the identification plate (Fig. 1, **Item 5**) is set to position 2 (corresponding to heating zone 2).

3 Wall-mounted boilers

This chapter describes installation of the xM10 function modules in a wall-hung boiler (in this example Logamax plus GB142).

Up to two function modules will fit inside a wall-hung boiler.

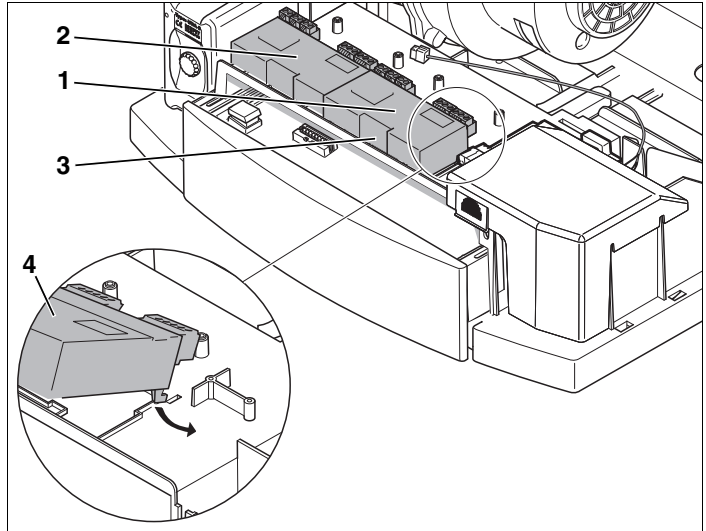

Fig. 2 Slide the function module into position, then push down ensuring that the lock is engaged

Item 1: Function module in slot 1

Item 2: Function module in slot 2

Item 3: Lock

Item 4: Function module

- Remove cover from the boiler (see the installation and maintenance instructions).
- Fit the function module (Fig. 2, **Item 4**) in the recesses using the locking tabs and push down to engage the lock (Fig. 2, **Item 3**.)

Making electrical connections



WARNING!

RISK OF LIFE

from electric shock.

- Isolate the heating system from electrical power by shutting off the emergency shut off switch, or the heating system circuit breaker, and take measures to prevent accidental reactivation.

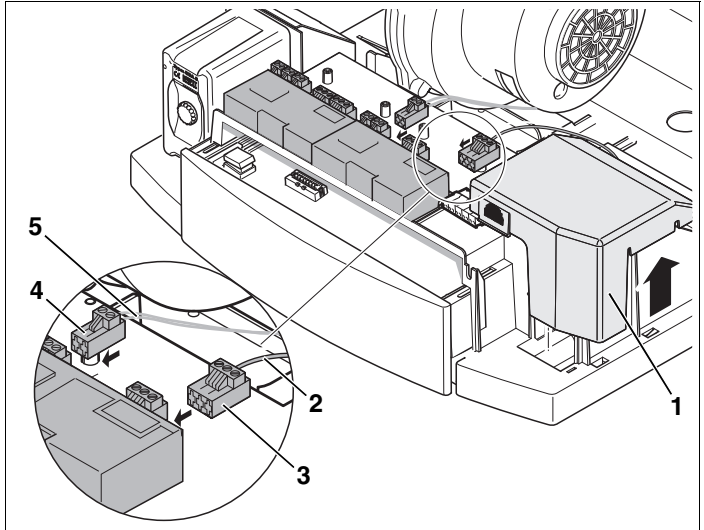

Fig. 3 Electrical connections

Item 1: Terminal box for boiler

Item 2: Mains supply cable (in cable harness)

Item 3: Terminals for 120-V inputs or outputs (e. g. for main power connection or pumps)

Item 4: Low-voltage terminals (e. g. for bus system or temperature sensors)

Item 5: Bus cable (in cable harness)

Using the terminals provided, connect the main power cable, bus cable and other components (e. g. pumps, temperature sensors etc.) to the function module according to the application. The exact assignment (components - terminals) is shown in the connection diagrams supplied with the equipment.

- Remove cover from terminal box (Fig. 3, **Item 1**).
- Carefully take the main power cable (Fig. 3, **Item 2**) and bus cable (Fig. 3, **Item 5**) from the boiler's cable harness and connect them to terminals (Fig. 3, **Item 3 and 4**) of the function module.
- Carefully connect other components to terminals (Fig. 3, **Item 3 and 4**) on the function module in accordance with the connection diagram.

If you install a second function module, bridge the mains supply cable and bus cable from the first to the second function module using the cables provided.



PLEASE NOTE

Ensure that the hot and neutral cables are connected to the correct terminals, and that the system is protected by a properly sized circuit breaker.

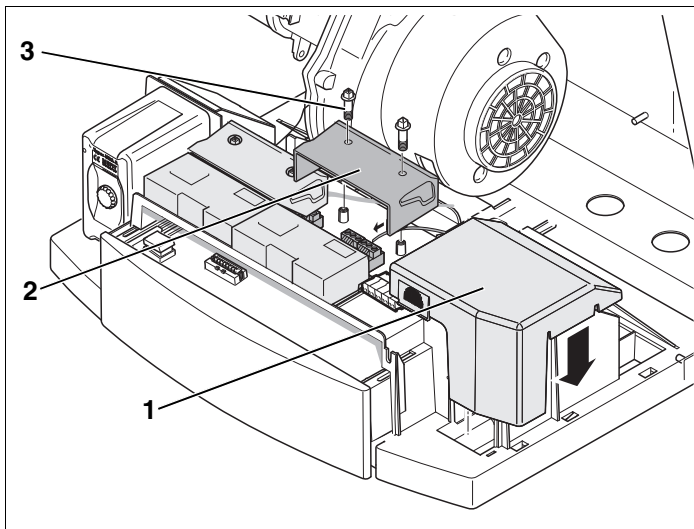

Fig. 4 Close terminal cover

Item 1: Terminal box cover

Item 2: Terminal cover on function module

Item 3: Phillips screw with square head

- Replace cover on terminal box (Fig. 4, **Item 1**).
- Replace terminal cover on function module (Fig. 4, **Item 2**).
- Tighten the Phillips screws (Fig. 4, **Item 3**) either with a Phillips screwdriver or with a bleeder key.
- Close the boiler cover.
- Commission the heating system and controller.

**PLEASE NOTE**

Connected pumps can sometimes start immediately after the system is powered up unless the controller has detected the function module. The heating system must be filled to ensure that the pumps do not run dry.

**PLEASE NOTE**

An RC35 control unit must be installed to ensure problem-free operation of the function modules.

- When commissioning the system, carry out all the required settings with the help of the service instructions provided.
- Check that the system conditions are set correctly in the control unit.

4 Floor-standing boilers

This chapter describes installation of the xM10 function modules in the Logamatic MC10 controller on floor-standing boilers.

Up to two function modules will fit inside an MC10 on a floor-standing boiler.

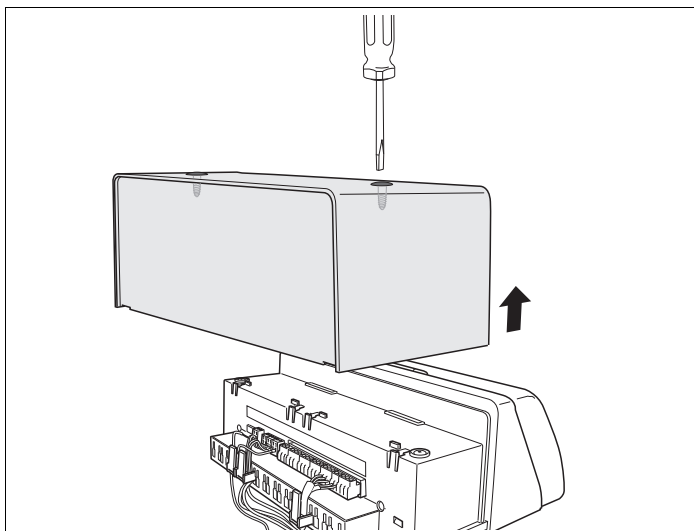

Fig. 5 Remove the cover

- Undo the 2 screws on the top of the cover (Fig. 5).
- Remove the cover by pulling upward as indicated by the arrow.

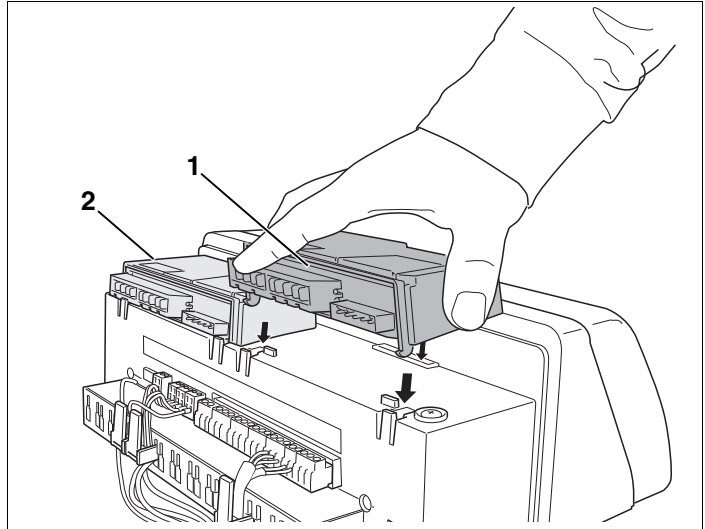

Fig. 6 Slide the function module into position, then push down, ensuring the lock is engaged

Item 1: Function module in slot 1

Item 2: Function module in slot 2 (if needed)

- Engage the hooks on the front of the function module to the tabs on the controller.
- Push down the back side of the module to engage the lock.

Making electrical connections



WARNING!

RISK OF LIFE

from electric shock.

- Isolate the heating system from electrical power by shutting off the emergency shut off switch, or the heating system circuit breakers, and take measures to prevent accidental reactivation.

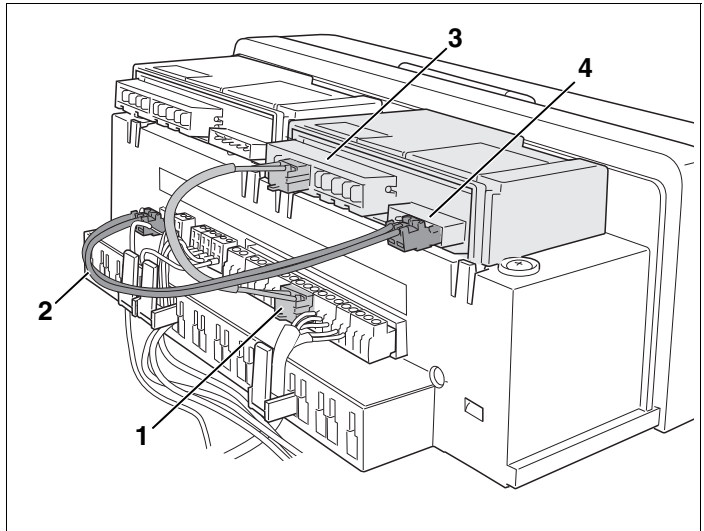

Fig. 7 Electrical connections

Item 1: Main power cable

Item 2: Bus cable

Item 3: Terminals for 120 V inputs or outputs (e. g. for mains connection or pumps)

Item 4: Low-voltage terminals (e. g. for bus system or temperature sensors)

Using the terminals provided, connect the main power cable, bus cable and other components (e. g. pumps, temperature sensors etc.) to the function module according to the application. The exact assignment (components - terminals) is shown in the connection diagrams supplied with the equipment.

- Carefully take the main power cable and bus cable (Fig. 7, **Item 1** and **2**) from the boiler's controller and connect them to terminals (Fig. 7, **Item 3** and **4**) on the first function module.
- Carefully connect other components to terminals (Fig. 7, **Item 3** and **4**) on the function module in accordance with the connection diagram.

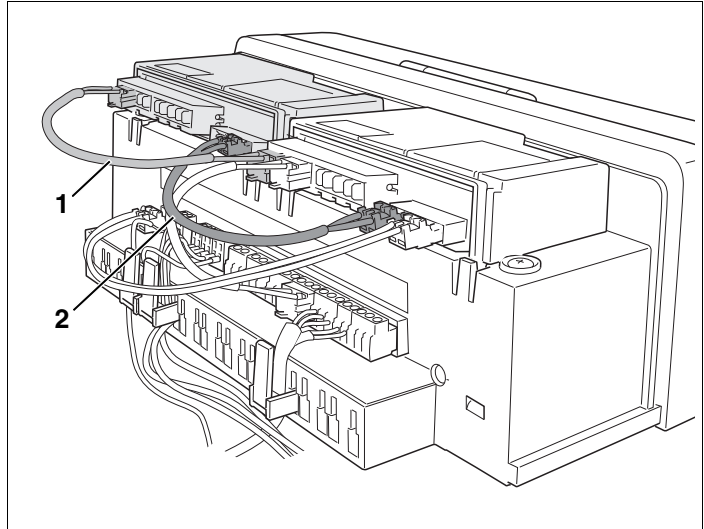

Fig. 8 Providing power to the second function module

Item 1: Main power cable

Item 2: Bus cable

If you install a second function module you must bridge the main power cable and bus cable from the first to the second function module using the cables provided.

Using the terminals provided, connect the main power cable, bus cable and other components (e. g. pumps, temperature sensors etc.) to the function module according to the application. The exact assignment (components - terminals) is shown in the connection diagrams supplied with the equipment.

- Carefully connect the main power cable and bus cable (Fig. 7, **Item 1** and **2**) from the first function module to the terminals on the second function module.
- Carefully connect other components to the terminals on the function module in accordance with the connection diagram.
- It is not necessary to fit the terminal cover.
- Commission the heating system and controller.

**PLEASE NOTE**

Connected pumps can sometimes start immediately after the system is powered up unless the controller has detected the function module. The heating system must be filled to ensure that the pumps do not run dry.

**PLEASE NOTE**

An RC35 control unit must be installed to ensure problem-free operation of the function modules.

- When commissioning the system, carry out all the required settings with the help of the service instructions provided.
- Check that the system conditions are set correctly in the control unit.

5 Wall mounting

This chapter describes the wall mounting of xM10 function modules.

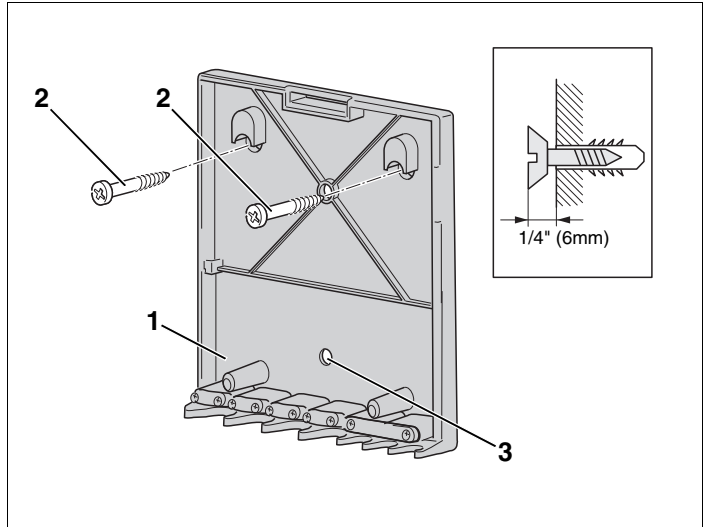

Fig. 9 Install wall bracket

Item 1: xM10 wall bracket

Item 2: Screws (4 × 45)

Item 3: Hole for more secure attachment

- Mark hole positions for the wall bracket (Fig. 9, **Item 1**).
- Drill holes according to the wall bracket's drilling template (Fig. 9, **Item 1**) 1/4" (6mm).
- Insert wall anchors in the holes and screw in the screws provided (Fig. 9, **Item 2**) until their heads are 1/4" (6mm) off the wall.

- Hook the wall bracket into position (Fig. 9, **Item 1**) and tighten screws. If necessary, secure the bracket (Fig. 9, **Item 1**) to the wall using its extra hole (Fig. 9, **Item 3**).

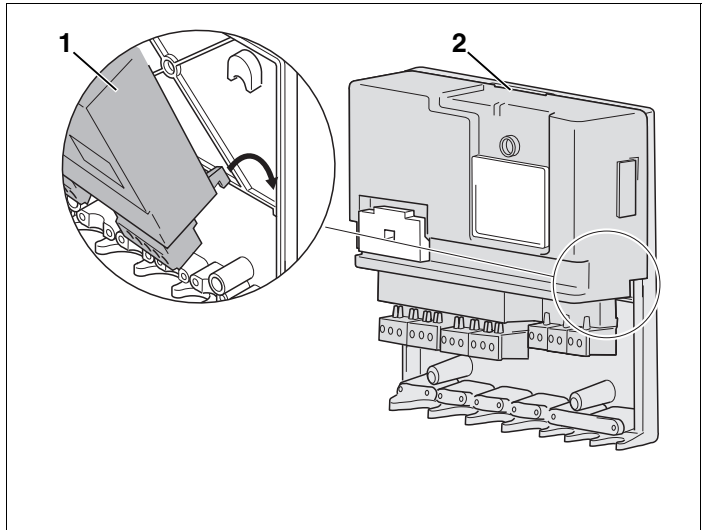

Fig. 10 Slide the function module into position, then push down, ensuring that the lock is engaged

Item 1: Function module

Item 2: Lock

- First fit the bottom tabs of the function module (Fig. 10, **Item 1**) in the wall holder. Then push the top into the wall bracket until the lock (Fig. 10, **Item 2**) engages.

Make electrical connections**WARNING!****RISK OF LIFE**

from electric shock.

- Isolate the heating system from electrical power by shutting off the emergency shut off switch, or the heating system circuit breaker, and take measures to prevent accidental reactivation.

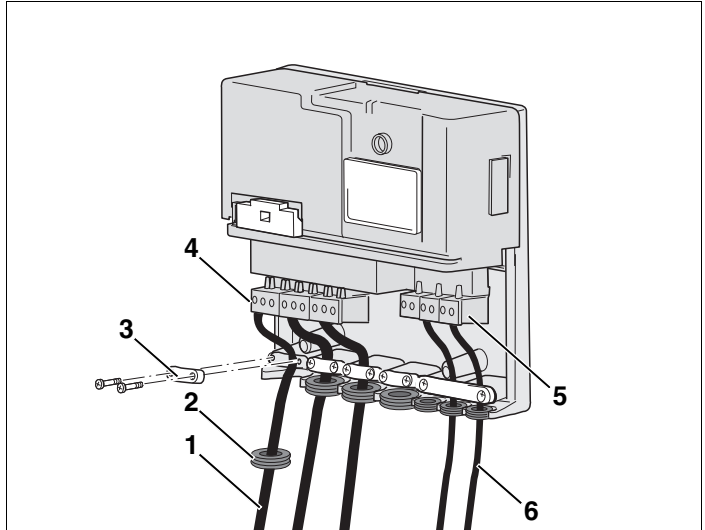

Fig. 11 Electrical supply connections

- Item 1:** Main power cable
- Item 2:** Rubber sleeve (e. g. for mains connection)
- Item 3:** Strain relief (e. g. for mains connection)
- Item 4:** Terminals for 120 V inputs or outputs (e. g. for main power connection or pumps)
- Item 5:** Low-voltage terminals (e. g. for bus system or temperature sensors)
- Item 6:** Bus cable

Using the terminals provided, connect the main power cable, bus cable and other components (e. g. pumps, temperature sensors etc.) to the function module according to the application.

The exact assignment (components - terminals) is shown in the connection diagrams supplied with the equipment.

- Start by fitting the rubber sleeves (Fig. 11, **Item 2**) over the cable.
- Carefully connect the main power cable (Fig. 11, **Item 1**, the bus cable (Fig. 11, **Item 6** and other components to terminals (Fig. 11, **Item 4** and **5** on the function module in accordance with the connection diagram.
- Secure the strain relief devices (Fig. 11, **Item 3**) correctly using the clips provided.



PLEASE NOTE

Ensure that the hot and neutral cables are connected to the correct terminals and that the system is protected by a properly sized circuit breaker.

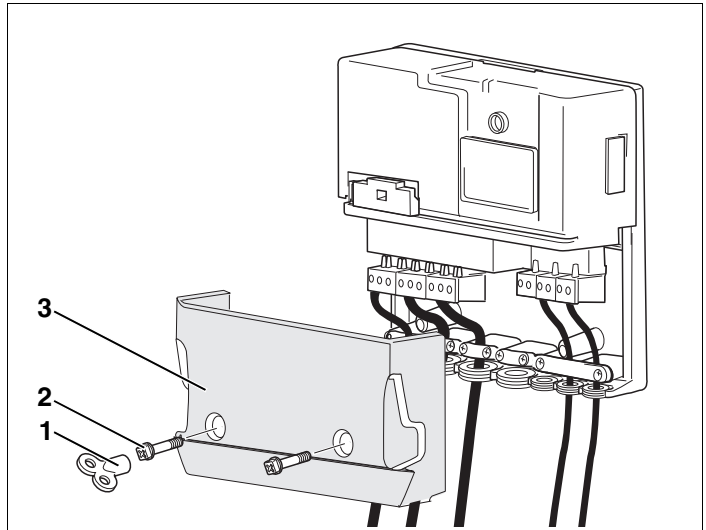

Fig. 12 Fit terminal cover

Item 1: Bleed key and/or screwdriver

Item 2: Phillips screw with square head

Item 3: Terminal cover

- Fit the terminal cover (Fig. 12, **Item 3**).
- Tighten the Phillips screw (Fig. 12, **Item 2** either with a Phillips screwdriver or with a bleeder key (Fig. 12, **Item 1**).
- Commission the heating system and controller.

**PLEASE NOTE**

Connected pumps can sometimes start immediately after the system is powered up unless the controller has detected the function module. The heating system must be filled to ensure that the pumps do not run dry.

**PLEASE NOTE**

An RC35 control unit must be installed to ensure problem-free operation of the function modules.

- When commissioning the system you should carry out all the required settings with the help of the service instructions provided.
- You should also check that the system conditions are set correctly in the control unit.

United States and Canada

Bosch Thermotechnology Corporation

50 Wentworth Avenue

Londonderry, NH 03053

U.S.A.

Tel. 603-552-1100

Fax 603-584-1681

www.buderus.net

Products manufactured by

Bosch Thermotechnik GmbH

D-35573 Wetzlar

www.buderus.de

Bosch Thermotechnology Corporation reserves the right to make changes without notice due to continuing engineering and technological advances.

Buderus