

Gas valve replacement instructions

Condensing gas boiler



Required Input Rates

Logamax plus GB162-80 kW 290,000 btu/hr	Logamax plus GB162-100 kW 333,000 btu/hr
--	---

This instruction is for replacing the gas valve for the GB162 model boilers with Natural Gas.

WARNING!

Replacement of a gas valve must be done by a qualified service agency in accordance with the manufacturer's instructions and all applicable codes and requirements of the authority having jurisdiction.

The information in these instructions must be followed to minimize the risk of fire or explosion or to prevent property damage, personal injury or death. The qualified service agency is responsible for the proper installation of this kit.

The installation is not proper and complete until the operation of the converted boiler is checked as specified in the manufacturer's instructions supplied with the gas valve.

CAUTION!

The gas supply shall be shut off prior to disconnecting the electrical power, before proceeding with the conversion.

Notice! Save these instructions for later use.

Logamax plus

**GB162-80 kW
GB162-100 kW**

For the contractor

Please read these instructions carefully

Contents

1	Safety considerations	3
1.1	Application purpose	3
1.2	Hazard definitions	3
1.3	Observe the following symbols	3

2	Parts list	4
----------	-------------------	----------

3	Gas valve replacement	5
3.1	Testing for gas leaks	7
3.2	Inlet gas pressure	7
3.3	Checking and adjusting the gas/air ratio	8
3.4	Carrying out a tightness test in operating conditions	9
3.5	Measuring the carbon monoxide content (CO)	9
3.6	Lighting Instructions	10

4	Operating Instructions	11
----------	-------------------------------	-----------

1 Safety considerations

For use in Canada the gas valve replacement shall be carried out in accordance with the requirements of the provincial authorities having jurisdiction and in accordance with the requirements of the CAN-B149.1 and CAN1-B149.2 Installation Code. See also E.I.V.

Please observe the following safety instructions.

1.1 Application purpose

This document describes how to replace the gas valve for the Logamax plus GB162-80 kW/100 kW.

1.2 Hazard definitions

The following defined terms are used throughout the documentation to bring attention to the presence of hazards of various risk levels. Notices give important information concerning the operation of the product.



DANGER:

Indicates the presence of hazards that will cause severe personal injury, death or substantial property damage.



WARNING:

Indicates the presence of hazards that can cause severe personal injury, death or substantial property damage.



CAUTION:

Indicates presence of hazards that will or cause minor personal injury or property damage.



CAUTION:

Risk of electric shock.
Indicates presence of hazards due to electric shock.



Indicates special instructions on installation, operation or maintenance that are important but not related to personal injury or property damage.

1.3 Observe the following symbols



DANGER:

due to explosion of gas.

- ▶ Work only on gas components when you have a license to do so.
- ▶ Note that the assembly of gas and vent connections, the initial start-up, the electrical connections, the maintenance and service can only be performed by a licensed service contractor or technician.



DANGER:

due to electricity.

- ▶ Prior to doing any work on the heating system, disconnect all electrical power to the appliance at the emergency switch.
- ▶ It is NOT sufficient to shut off only the appliance control!

2 Parts list

The gas valve spare part for the 80 kW/100 kW
7746900399 includes:

- assembly # 774601465A
 - gas valve Natural Gas
 - venturi
 - orifice # 432.438A (dia. 8.40 mm / 0.331 inch)
- bag
- these instructions
- o-ring (fan-venturi)
- sealing (gas pipe)
- Torx keys Tx25 and Tx30
- Torx screws (flange).

3 Gas valve replacement

To replace the gas valve the following instructions must be adhered to:



DANGER:

flammable gas explodes.
Only carry out work on gas conduits and fittings if you are licensed for such work.

Shut down the boiler

- ▶ Turn off the gas supply underneath the boiler.
- ▶ Switch off the heating system using the main switch (→ fig. 1).
- ▶ Disconnect the electrical power to the boiler.
- ▶ Set the thermostat or other operating control to lowest setting.

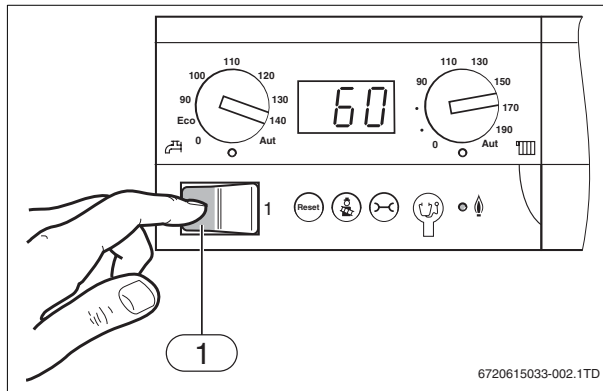

Fig. 1 Mains switch

- ▶ Open the boiler door by turning the vent key through ¼ rotation (→ fig. 2).

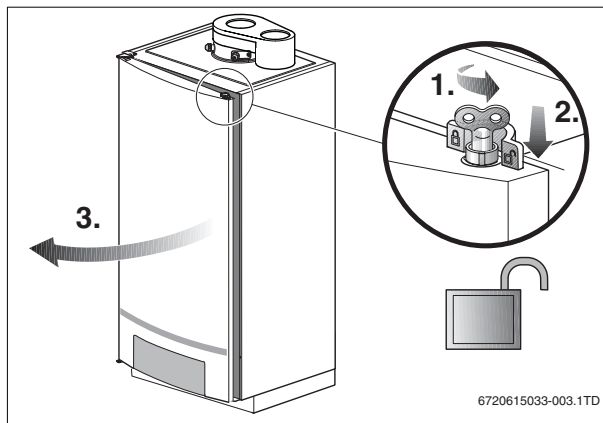

Fig. 2 Opening the boiler door

Changing the gas valve assembly

- ▶ Loosen the screw connection on the gas valve (→ fig. 3, [1]) and pull the plugs (→ fig. 3, [2]) from the gas valve.

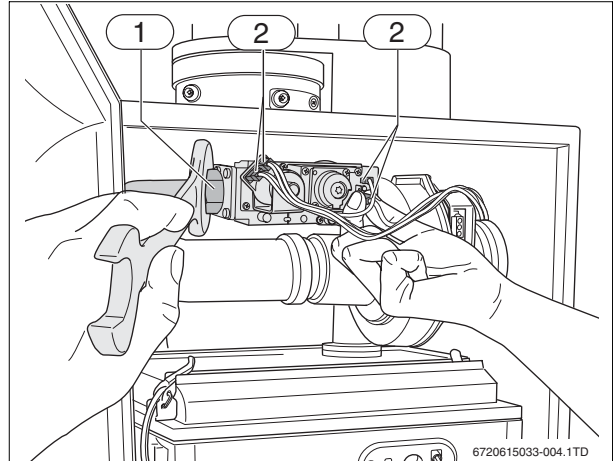

Fig. 3 Undoing the connections to the gas valve

- ▶ Pull both plugs from the fan unit (→ fig. 4, [1]).

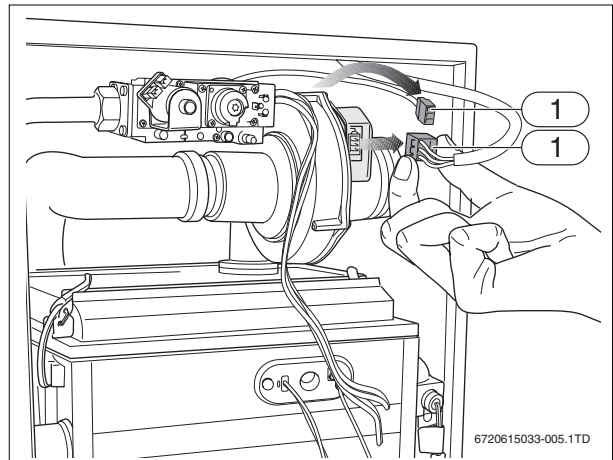

Fig. 4 Removing the connectors from the fan

- ▶ Pull the air suction tube from the fan (→ fig. 5).

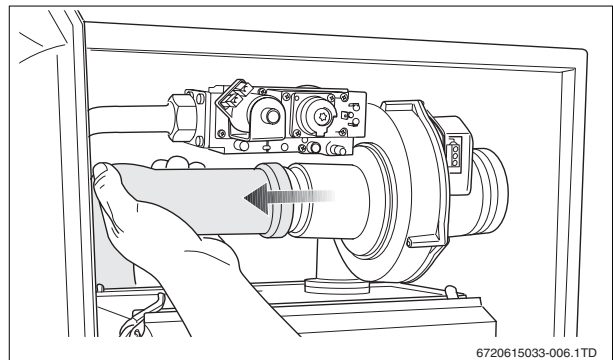

Fig. 5 Pulling the air suction tube from the fan

- ▶ Loosen both retaining clips on the burner cover (→ fig. 6).

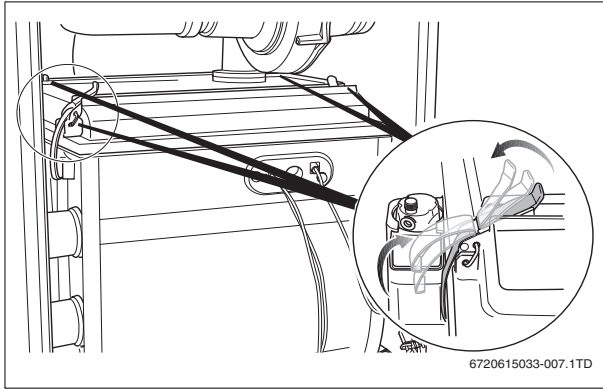

Fig. 6 Opening the retaining clips

- ▶ Remove the burner cover together with the fan unit and the gas valve (→ fig. 7).

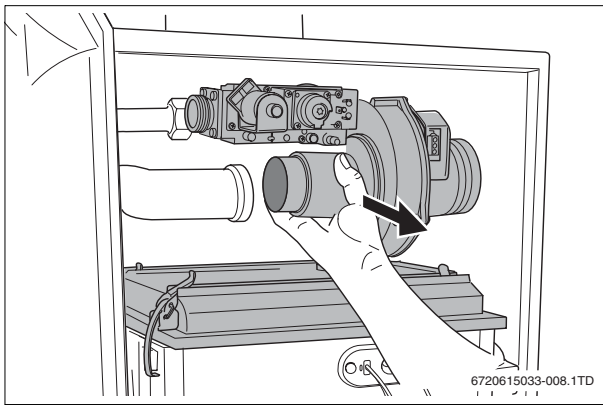

Fig. 7 Removing the burner cover with the gas/air unit

- ▶ Undo the three screws (→ fig. 8, [1]) and remove the gas valve with the venturi from the fan unit (→ fig. 8, [2]).
- ▶ Take the gas valve and venturi from the box.

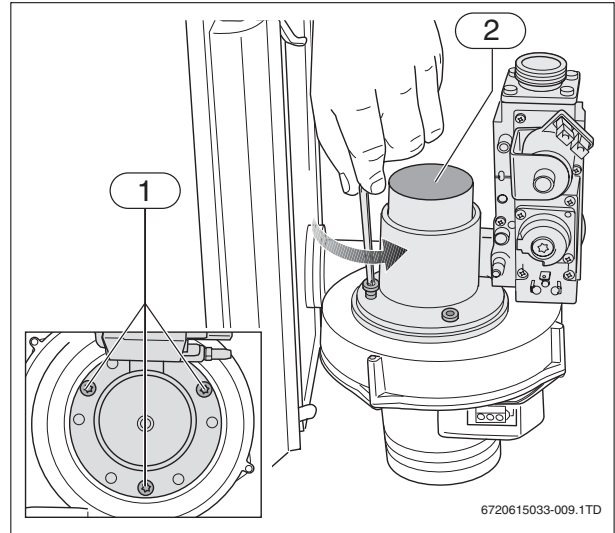

Fig. 8 Removing the screws and gas valve with venturi

- ▶ Install the venturi and gas valve on the fan unit using a new O-ring (→ fig. 9) and follow the instructions above in reverse order.

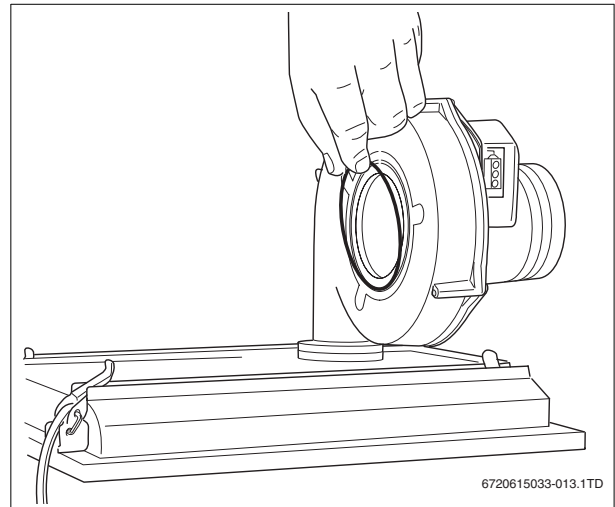

Fig. 9 Placing a new O-ring on the fan unit

- ▶ Install the gas flange from the natural gas assembly on the new gas valve (→ fig. 10, [1]).

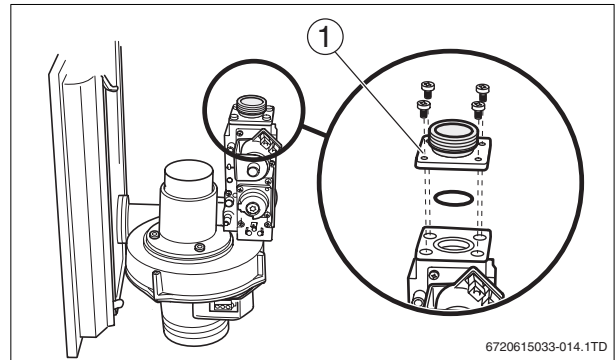

Fig. 10 Installing the gas flange

Thermal power gas boiler	Type of gas supply	Altitude in ft (m)	Gas orifice diameter in mm (inch)	Venturi article number
GB162-80 kW/100 kW	Natural gas	0 - 4,000 (0 - 1,220)	8.40 (0.331)	73983

Tab. 1 Gas orifice diameter

- ▶ Remove the seal from the gas pipe and install a new seal (→ fig. 11).

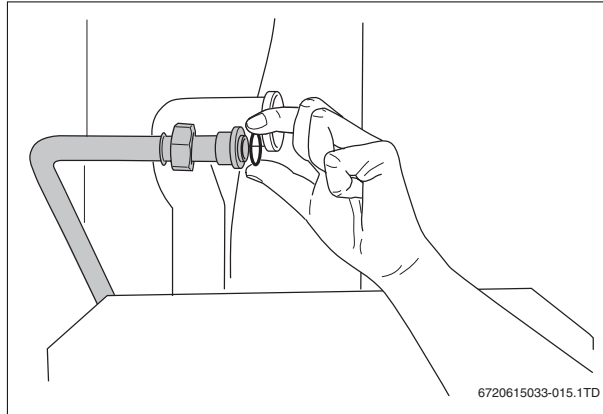

Fig. 11 Installing a new seal on the gas pipe

- ▶ Refit all parts in reverse order. When re-installing the burner plate, make sure that the notch is on the right-hand side (→ fig. 12).
- ▶ Carry out the start-up activities and complete a new start-up report.
- ▶ Also check all joints and gaskets affected by the installation activities while carrying out the tightness test in operating conditions.
- ▶ Close the boiler door and lock the fastener by turning the vent key through ¼ rotation in a clockwise direction.

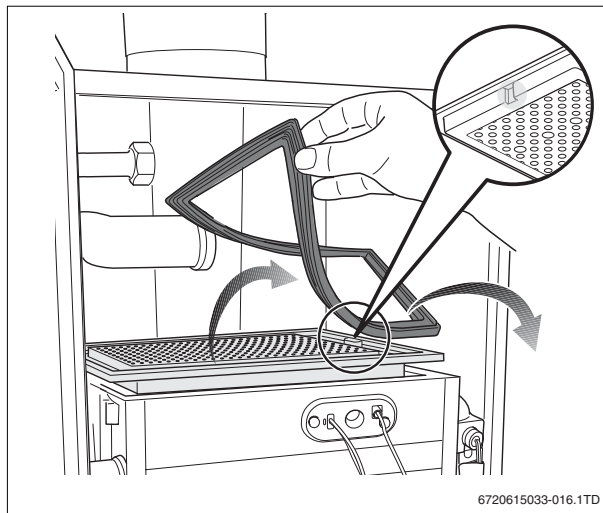

Fig. 12 Re-installing the burner plate

3.1 Testing for gas leaks

Prior to start-up of the boiler you must check the external tightness of the gas supply valve and confirm this in the start-up report.



CAUTION:

due to a short circuit.

- ▶ Cover damageable parts before leak testing.
- ▶ Do not spray the leak testing agent onto cables, plugs or electrical connection lines. Do not allow it to drip onto them either.



DANGER:

Leaks may be caused to pipes and screw connections during commissioning and maintenance activities.

- ▶ Carry out a proper leak test.
- ▶ Only use approved leak detection agents for leak detection.

- ▶ Disconnect the heating system from the power supply.
- ▶ Check the exterior tightness of new conduit sections up to and including the direct sealing point on the gas burner fitting. The maximum test pressure allowed on the input of the gas burner fitting is 60 inch W.C. (150 mbar).
- ▶ Check the input rates after to the values on the front page.

3.2 Inlet gas pressure

- ▶ Open at least one thermostatic radiator valve if present to allow water to flow through the boiler. Do not switch on the boiler.
- ▶ Close the gas shut-off valve. Loosen the screw plug on the inlet gas pressure testing nipple by two turns (→ fig. 13, [1]).
- ▶ Connect the pressure gauge connection hose to the testing nipple (→ fig. 13, [2]).
- ▶ Slowly open the gas shut-off valve.

The boiler and its individual shutoff valve must be disconnected from the gas supply piping system during any pressure testing of that system at test pressures in excess of 60 inch W.C. (150 mbar).

The boiler must be isolated from the gas supply piping system by closing its individual manual shutoff valve during any pressure testing of the gas supply piping system at test pressures equal to or less than 60 inch W.C. (150 mbar).

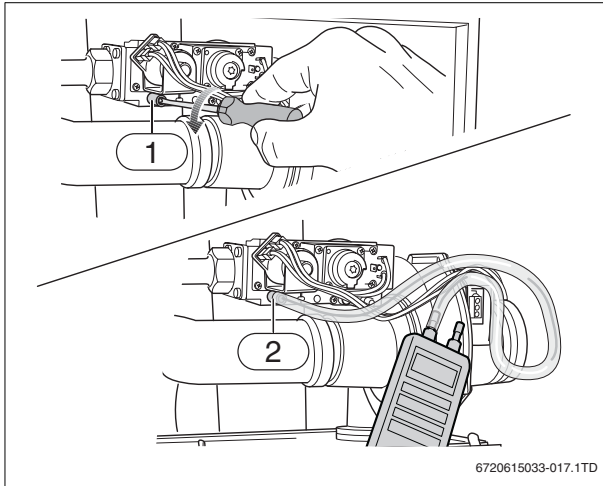

Fig. 13 Measuring the gas supply pressure

- ▶ Briefly press on the control panel cover to open it.

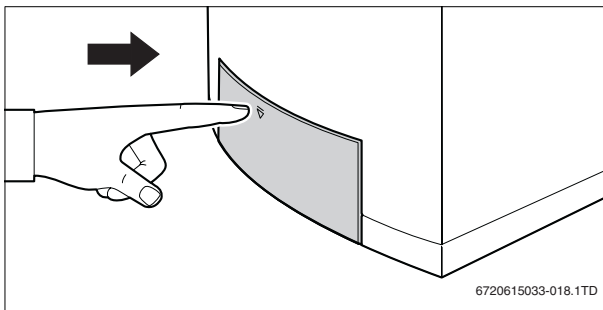





Fig. 14 Opening the control panel

- ▶ Switch on the heating system by setting the main switch to position "1" (→ fig. 1, page 5).
- ▶ Press the "Chimney Sweep"  button and hold it (for approx. two seconds) until the display shows a decimal point.

- ▶ Measure the gas connection pressure as soon as the "Burner" LED lights and enter this value in the start-up report.

The inlet gas pressure must be:

- for natural gas - min. 7.0 to 10.5 inch W.C. (17.4 to 26.1 mbar), nominal supply pressure 8.0 inch W.C. (19.9 mbar)
- ▶ Repeatedly press the "Service"  button until the temperature indication is displayed.
- ▶ Press the "Chimney Sweep"  button to end the measurement procedure.
- ▶ Close the gas shut-off valve.
- ▶ Remove the connection hose again and tighten the screw plug on the testing nipple.
- ▶ Open the gas shut-off valve again.



- ▶ Contact the relevant gas utility company if the required inlet gas pressure is not available.
- ▶ Install a gas pressure regulator before the gas burner fitting if the supply pressure is too high.

3.3 Checking and adjusting the gas/air ratio

- ▶ Switch off the heating system using the main switch.
- ▶ Loosen the screw plug on the measuring nipple for the burner pressure by two rotations (→ fig. 15, [1]).
- ▶ Set the pressure gauge to zero.
- ▶ Use a hose to connect the plus terminal of the pressure gauge to the burner pressure measuring nipple (→ fig. 15, [2]).

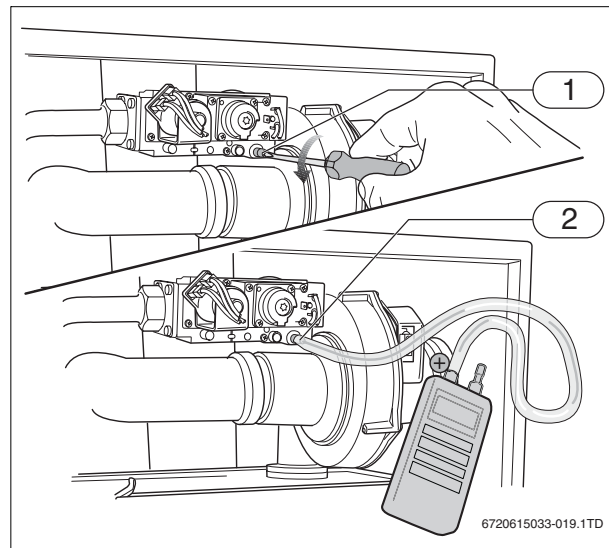







Fig. 15 Checking the gas/air ratio

- ▶ Switch on the heating system using the main switch.
- ▶ Press the "Chimney Sweep"  button and hold it (for approx. two seconds) until the display shows the decimal point.
- ▶ Press and hold the "Chimney Sweep"  and "Service"  buttons (for approx. five seconds) until the display shows "Lxx" (e. g. L80).
- ▶ Set the boiler to partial load "L25" for the 80 kW and "L20" for the 100 kW boiler by pressing the "Chimney Sweep"  button (higher values) or the "Reset"  button (lower values).
- ▶ Read out the differential pressure. The differential pressure (pGas – pAir) must be -0.02 inch W.C. (- 5 Pa) (± 0.02 inch W.C. = ± 5 Pa) (read-out on pressure gauge: -0.04 – 0 inch W.C. = -10 – 0 Pa).
- ▶ Enter the value measured in the start-up report.

- ▶ If the gas/air ratio is not correct it can be adjusted using the adjustment screw (→ fig. 16, [1]). The adjustment screw is located behind the cover screw.

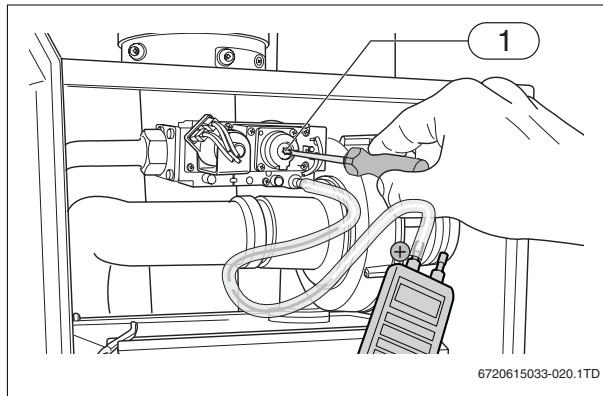

Fig. 16 Setting the gas/air ratio

- ▶ Repeatedly press the "Service" (⚙️) button until the temperature indication is displayed.
- ▶ Press the "Chimney Sweep" (🧹) button until the decimal point is cleared from the display.
- ▶ Switch off the heating system using the main switch.
- ▶ Remove the measurement set-up, tighten the screw in the burner pressure measuring nipple.
- ▶ Switch on the heating system using the main switch.

3.4 Carrying out a tightness test in operating conditions

- ▶ Check all gaskets and joints in the burner gas circuit for leaks while the burner is operational, using a foaming agent.



DANGER:

Leaks may be caused to pipes and screw connections during start-up activities if flammable gas explodes.

- ▶ Only use approved leak detection agents for leak detection such as a soapy water solution.



CAUTION:

due to a short circuit.

- ▶ Cover damageable parts before leak testing.
- ▶ Do not spray the leak testing agent onto cables, plugs or electrical connection lines. Do not allow it to drip onto them either.

3.5 Measuring the carbon monoxide content (CO)

- ▶ Measure the carbon monoxide content on the flue gas sampling point (→ fig. 17, [1]).

The CO values in an air-free condition must be below 400 ppm or 0.04 vol. %.

Values of 400 ppm and up indicate that the burner adjustment may be wrong, the gas burner fitting or the heat exchanger are dirty or that there may be burner faults.

- ▶ You must establish and resolve the cause. The boiler must be operational when you do this.

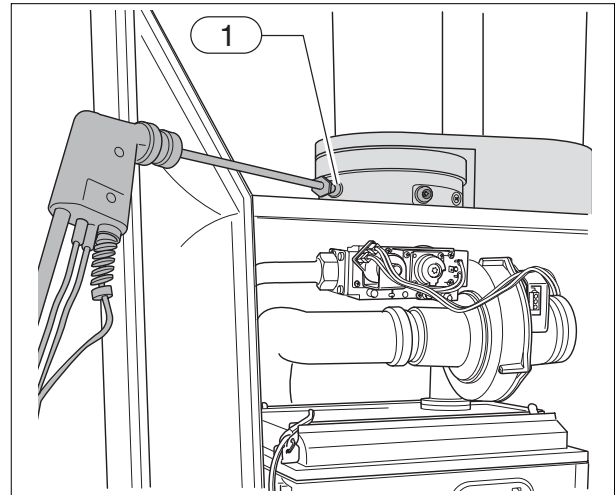

Fig. 17 Measuring the carbon monoxide content

3.6 Lighting Instructions

For your safety, read before lighting.

**WARNING:**

due to not follow these instructions.

- ▶ If you do not follow these instructions exactly, a fire or explosion may result causing property damage, personal injury or loss of life.
- ▶ Follow these operating instructions.

**DANGER:**

What to do if you smell gas:

- ▶ No open fire! Do not smoke!
- ▶ Avoid formation of sparks! Do not touch any electric switch, phone, electric plug or bell!
- ▶ Shut off main gas supply.
- ▶ Open windows and doors!
- ▶ Notify all occupants!
- ▶ Leave the building!
- ▶ Immediately call your gas supplier, heating contractor or fire department from a phone outside the building!

A) This boiler is equipped with an ignition device which automatically lights the pilot. Do not try to light the pilot by hand.

B) Check for smell of gas around the boiler area. Be sure to smell next to the floor because some gas is heavier than air and will settle on the floor.

C) Do not use this boiler if any part has been under water. Immediately call a qualified service technician to inspect the boiler and to replace any part of the control system and any gas control which has been under water.

4 Operating Instructions

Start up the boiler

STOP!

Read the safety precautions on page 10 of this manual.

- ▶ Wait five (5) minutes to clear out any gas. Then smell for gas, including near the floor. If you smell gas, STOP! Follow "B" in the safety information on page 10. If you do not smell gas, go to the next step.
- ▶ Fit the casing again.
- ▶ Open the gas shut-off valve.
- ▶ Set the thermostat or other operation control to desired setting.
- ▶ Connect the heating system to the power supply.
- ▶ Switch on the heating system using the main switch (→ fig. 18).

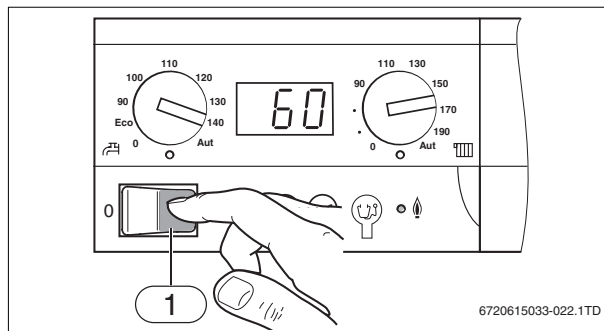

Fig. 18

United States and Canada

Bosch Thermotechnology Corp.
50 Wentworth Avenue
Londonderry, NH 03053
Tel. 603-552-1100
Fax 603-584-1681
www.buderus.net
U.S.A.

Products manufactured by
Bosch Thermotechnik GmbH
Sophienstrasse 30-32
D-35576 Wetzlar
www.buderus.de

Bosch Thermotechnology Corp. reserves the right
to make changes without notice due to continuing
engineering and technological advances.

6720615152 0002

Buderus