



CAUTION!

Observe the safety instructions of this installation and maintenance manual before placing the boiler in operation.

DANGER!

If installation, adjustment, modification, operation or maintenance of the heating system is carried out by an unqualified person, this may result in danger to life and limb or property damage. The directions of this installation and maintenance manual must be followed precisely. Contact a qualified service company, service provider or the gas company if support or additional information is required.

CAUTION!

The operating manual is a component of the technical documentation and must be handed over to the operator of the heating system. Discuss the instruction in this manual with the owner or operator of the heating system to ensure that they are familiar with all information required for operation of the heating system.

NOTICE!

In the Commonwealth of Massachusetts this appliance must be installed by a licensed plumber or gas fitter.

Logano plus GB312



Table of Contents

1	Product description	4	7	CSD-1 Kit	31
1.1	Package contents	6	7.1	Operating Addendum for the GB312 in High Temperature Applications	33
1.2	Dimensions and specifications	7			
2	Installing the boiler	10	8	Internal boiler wiring diagram	34
2.1	Recommended wall clearances	10			
2.2	Leveling the boiler	11	9	MC10 wiring diagram	35
3	Water quality requirements	12	10	Sequence of operations	36
3.1	Maintenance of user manual	12			
3.2	Prevention of damage by corrosion	12	11	High altitude adjustment	37
3.3	Water hardness	13	11.1	General	37
3.4	Checking max quantity of first fill water based on water quality	13	11.2	Adjustments	37
3.5	pH requirements	13	11.3	CO ₂ adjustment of the burner / adjustment of the gas valve	37
3.6	Operator's log	15	11.4	Setting for speed of burner fan	40
4	Openings for combustion air supply & venting	16	12	Examples of installations	42
5	Venting requirements	17	12.1	Legend	42
5.1	Connecting the air supply (for direct vent operations)	19	12.2	Single boiler systems	43
5.2	Installing the wall exit for air supply pipe	19	12.3	Multiple boiler systems	49
5.3	Installing the roof exit for air pipe	20	13	Pump and low loss header selection	57
5.4	Design of flue and air pipe for balanced flue operation (refer to NFPA54 ANSI Z223.1 for dimensions)	21	13.1	Pump & low loss header (hydro-separator) selection	57
5.5	Venting system calculation/sizing chart	22	13.2	Low loss header selection per manufacturer	58
6	Piping the boiler	26			
6.1	Connecting central heating supply	26			
6.2	Fitting the heating system return	26			
6.3	Installing the DHW Tank	26			
6.4	Installing the condensate drain	26			
6.5	Connecting the fuel supply	27			
6.6	Pipe sizing	29			

1 Product description

The Logano plus GB312 (Fig. 1) is supplied with a fully factory-fitted and ready-wired Logamatic BC10 basic programmer.

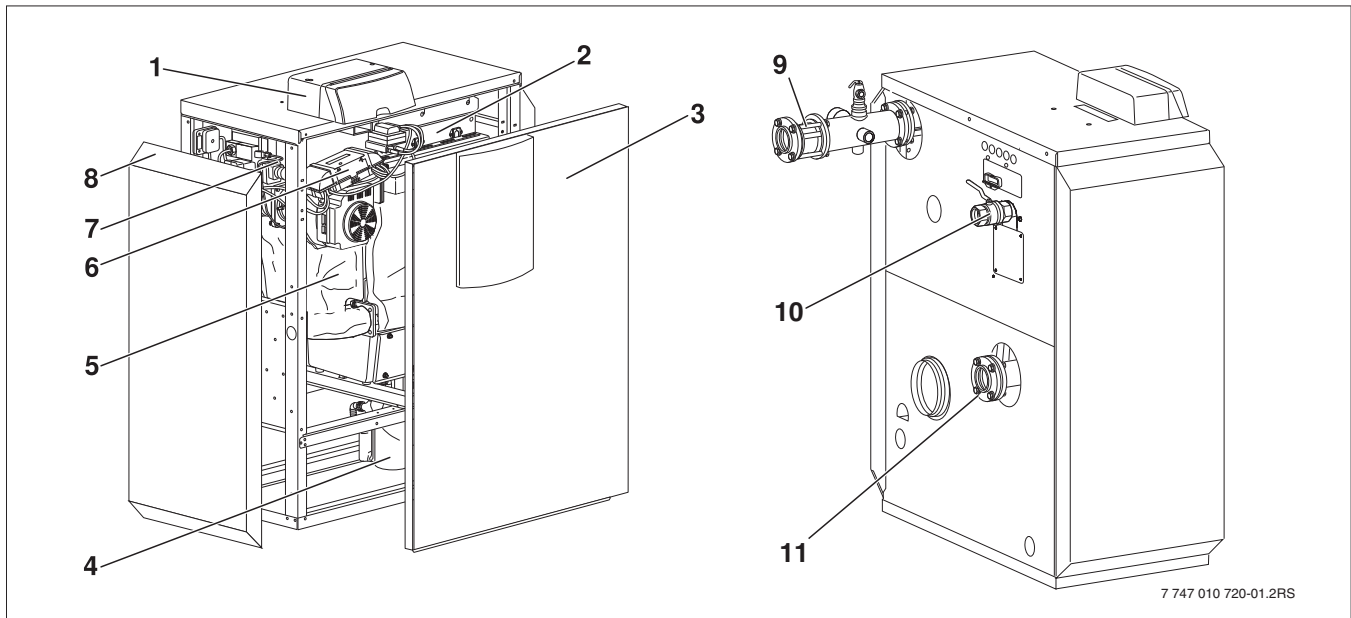

Fig. 1 Logano plus GB312 - main components

- 1 Programmer (MC10 and BC10)
- 2 Gas burner
- 3 Boiler front panel
- 4 Trap
- 5 Boiler heat exchanger with insulation
- 6 Burner control unit
- 7 Gas valve
- 8 Boiler outer casing
- 9 B-kit with flow check valve (supplied as standard, not factory installed)
- 10 Gas isolating valve (supplied as standard, not factory installed)
- 11 Mating flange, 2½" (included in B-kit, not factory installed)

The main components of the Logano plus GB312

(□Fig. 1) are:

- Programmer — Item 1
- Frame and casing — Item 8
- Boiler heat exchanger with insulation — Item 5
- Gas burner — Item 2
- B-kit (standard B-kit comprising temperature/pressure gauge, pressure relief valve, supply manifold, mating flange for flow/return piping, not factory installed)
- Gas isolating valve — Item 10

The programming unit monitors and controls all electrical boiler components.

The boiler heat exchanger transfers the heat generated by the burner to the heating water. The thermal insulation reduces radiant and standby heat loss.

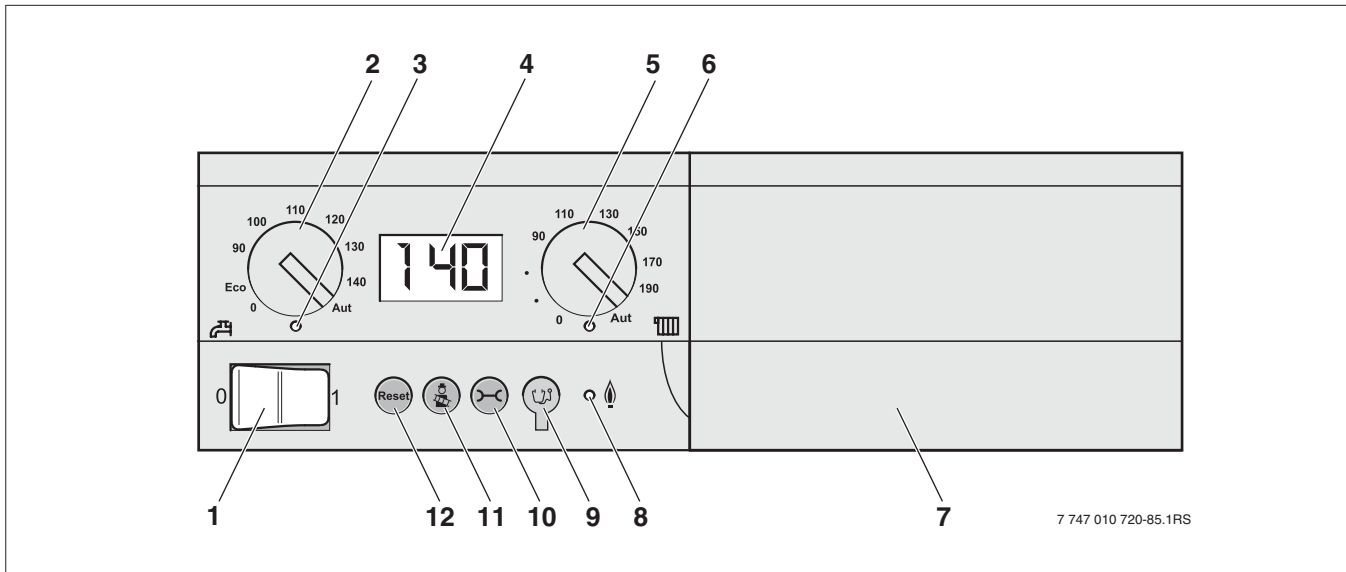

Fig. 2 Logamatic BC10 basic programmer - controls

- 1 On/off switch
- 2 Dial for DHW set point
- 3 "DHW heating" LED
- 4 Status display screen
- 5 Control knob for maximum boiler temperature
- 6 "Heat demand" LED
- 7 Base plate with slot for a programming unit e.g. RC35 (available : Fall 2008) (behind the cover panel)
- 8 "Burner" LED (ON/OFF)
- 9 Socket for connecting diagnostic plug
- 10 "Status display" button
- 11 "Flue gas test" button
- 12 "Reset" button

Logamatic BC10 basic programmer (□Fig. 2). The Logamatic

BC10 basic programmer enables basic operation of the heating system. It provides functions such as the following for that purpose:

- Turning the heating system on/off
- Setting the DHW temperature and the maximum boiler temperature in heating mode
- Status display

On overall picture of the controls of the Logamatic BC10 basic programmer can be obtained from Fig. 2.

Many other functions for the convenient control of your heating system are available with a programming unit (such as the RC35*).

* The RC35 is to be used as a master control, as well as a boiler service tool.

1.1 Package contents

The Logano plus GB312 is supplied complete with BC10 basic control unit and MC10 programming unit.

- On delivery, check that the packaging is undamaged.
- Check that all package contents are present.
- Dispose of packaging in an environmentally responsible manner.

Component	Packaging
Boiler (fully assembled with outer casing, Logamatic MC10 programming unit, BC10 and gas isolating valve)	1 box on a pallet
Technical documentation	1 foil package
Set of adjustable feet	1 foil package
B-kit (temperature/pressure gauge, pressure relief valve, supply connector flow/return mating flange, check valve)	1 box

1.2 Dimensions and specifications

1.2.1 Logano plus GB312 dimensions

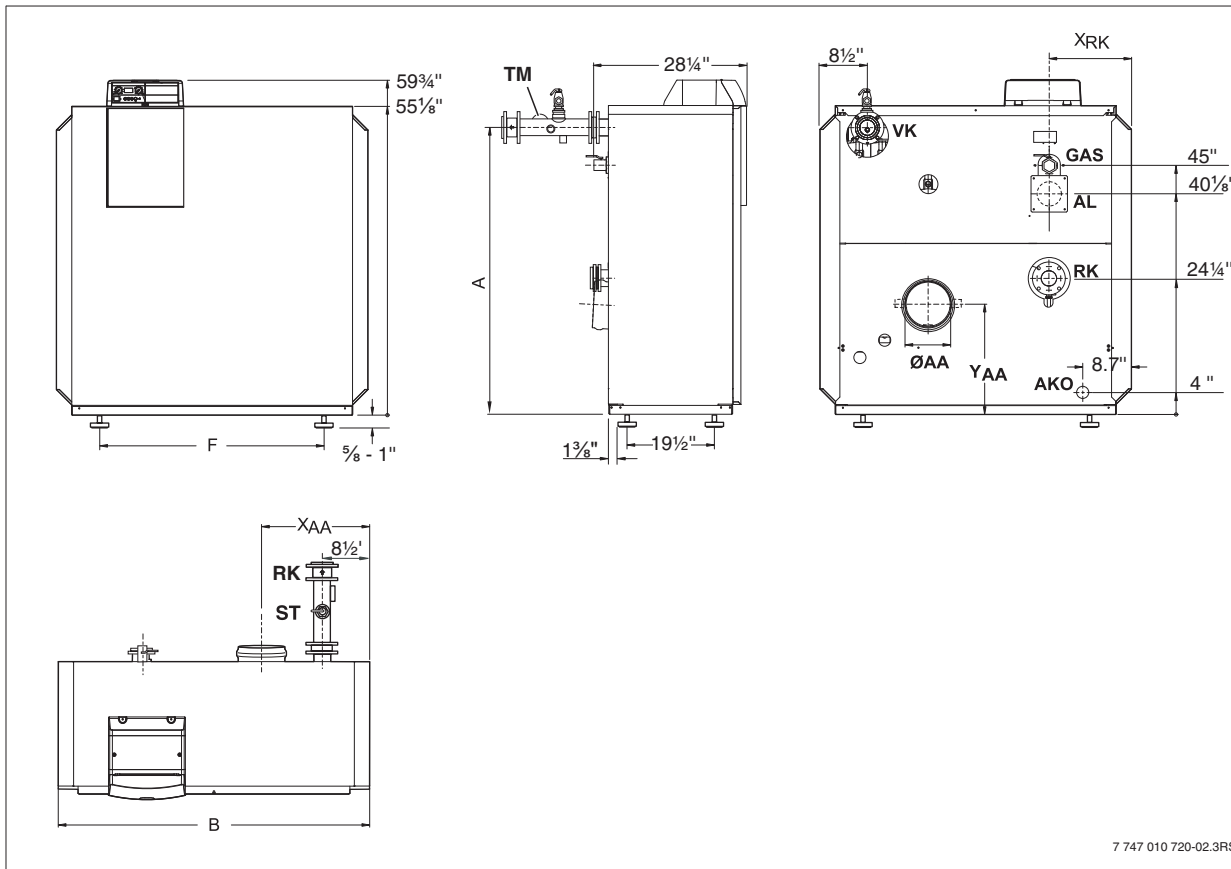

Fig. 3 Connections and dimensions for Logano plus GB312 (sizes in inches)

- AA = Flue connection
- AL = Combustion air pipe connection (balanced flue operation only)
- VK = Boiler supply
- AKO = Condensate outlet
- GAS = Gas connection + main isolating valve
- ST = Pressure relief valve connection
- RK = Boiler return
- TM = Pressure/temperature gauge

Boiler size (output - no. of heat exchanger sections)	Model	90 - 4	120 - 4	160 - 5	200 - 6	240 - 7	280 - 8	
Width B	Inches	39 $\frac{1}{8}$		47 $\frac{3}{8}$		55 $\frac{1}{2}$		
Dimension XAA	Inches	13 $\frac{1}{8}$		15 $\frac{1}{8}$	17 $\frac{1}{4}$	19 $\frac{1}{4}$	21 $\frac{3}{8}$	
Dimension XRK (= XAL = XGAS)	Inches	10 $\frac{5}{8}$		14 $\frac{3}{4}$	10 $\frac{5}{8}$	14 $\frac{3}{4}$	10 $\frac{5}{8}$	
Dimension F	Inches	31 $\frac{1}{2}$		39 $\frac{3}{4}$		48		
Dimension A	Inches	51 $\frac{1}{2}$		51 $\frac{1}{2}$				
AA = Flue pipe diameter	Inches	6 $\frac{3}{8}$			8			
Flue adaptor for desired manufacturer's flue system		6 $\frac{3}{8}$ " x 5"		6 $\frac{3}{8}$ " x 6"		8" x 8"		
Dimension YAA	Inches	18 $\frac{1}{2}$			19 $\frac{1}{2}$			
Dimension ZAA	Inches	5 $\frac{3}{4}$			12 $\frac{1}{4}$			
AL = Diameter of combustion air pipe (balanced flue only)	Inches	4 (Use rubber plumbing adaptor to connect)						
Connections VK and RK		2 $\frac{1}{2}$ " NPT						

Tab. 1 Dimensions and connection sizes

Boiler size (output - no. of heat exchanger sections)	Model	90 - 4	120 - 4	160 - 5	200 - 6	240 - 7	280 - 8	
Connection ST (B-kit)		¾" NPT					1" NPT	
Diameter GAS		1" NPT			1 ¼" NPT			

Tab. 1 Dimensions and connection sizes

1.2.2 Specifications



Observe all standards and guidelines applicable to the installation and operation of the heating system in your country. The information on the boiler rating plate is definitive and it is imperative that it is observed.

Boiler size (output - no. of heat exchanger sections)	Model	90 - 4	120 - 4	160 - 5	200 - 6	240 - 7	280 - 8	
Natural gas								
I-B-R Input	max. load	Btu/hr	328,300	440,500	588,300	732,600	880,700	1,028,800
	min. load	Btu/hr	132,150	132,000	176,000	220,000	264,000	309,000
I-B-R gross output 180/80 ° F	max. load	Btu/hr	305,000	409,000	544,000	676,000	810,000	944,000
I-B-R net rating 180/80 ° F	max. load	Btu/hr	265,000	356,000	473,000	588,000	704,000	821,000
Rated heat input 122/86 ° F (50/30 ° C)	max. load	Btu/hr	307,090	409,460	545,940	682,430	818,910	955,400
	min. load	Btu/hr	128,050	127,390	171,190	212,310	255,220	298,140
Flue gas mass flow rate 180/80 ° F	max. load	lb/min	4.85	6.53	9.14	11.40	13.88	16.15
Flue gas mass flow rate 122/86 ° F	max. load	lb/min	5.05	7.12	9.29	11.61	14.02	16.65
Flue gas temperature 180/80 ° F	max. load	° F	83	90	127	138	140	134
Flue gas temperature 122/86 ° F	max. load	° F	120	133	129	131	131	135
CO2 content, natural gas	max. load	%	9.1					
	min. load	%	9.1					
Available flue pressure (flue draft + air supply pressure)		in. W.C.	0.4 (100 Pa)					
Air supply volumetric flow rate		cfm	95	95	130	160	190	220
Blower			G1G 170					
Honeywell gas valve			V4730C1071		V4730C1097		V4730C1063	
Gas injector diameter			17.0					
Natural gas calorific value 1075 BTU/ft3		mm	17.0					
Heating water circuit								
Boiler water capacity		US gallons	4.2	4.2	5.3	6.3	7.1	7.9
Primary pressure drop		psi	→ Fig. 4 (graph)					
Maximum flow temperature, heating/hot water mode (at full output)		° F	180/180					
High temperature cut-out safety limit (manual reset high limit setting)		° F	200					
Boiler size (output - no. of heat exchanger sections)	Unit		90 - 4	120 - 4	160 - 5	200 - 6	240 - 7	280 - 8
Permissible operating pressure	psi		50					
Electrical data								
Enclosure class			IP 40					
Mains power supply	V/Hz		120 V / 60 Hz					
Power consumption	max. load	W	84	150	190	230	270	370
	min. load	W	40	40	45	50	50	50
Maximum permissible fuse rating	A		10 (slow blow)					
Appliance dimensions and weight								
Transport clearance dimensions, width x depth x height	Inches		34x25x60		42x25x60		50x25x60	
Weight	lbs		455		530		585	

Tab. 2 Specifications

Buderus

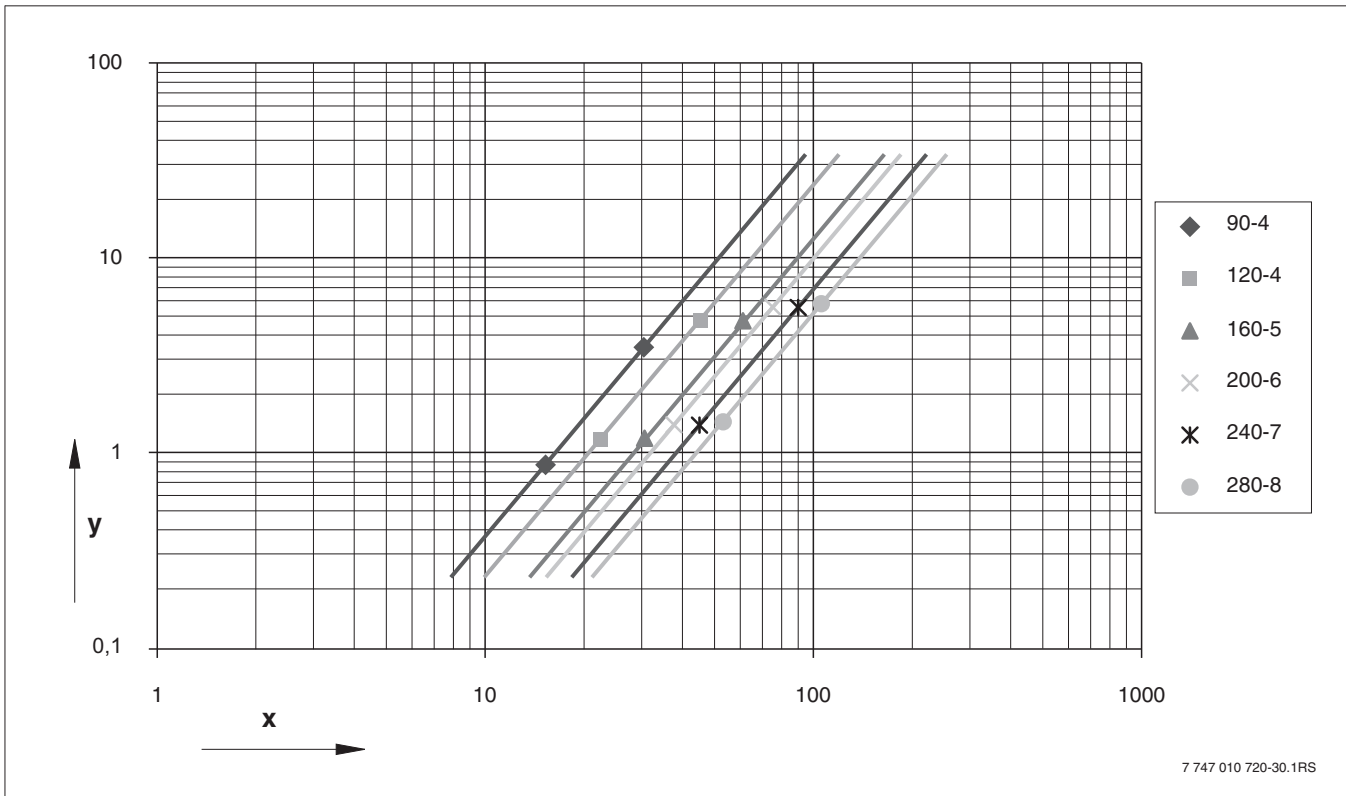

Fig. 4 Primary circuit flow resistance, GB312 with check valve

x Flow rate in gal/min (GPM)
 y Primary pressure drop in psi

Boiler rating	Gas flow rate
	Natural gas Calorific value 1075 BTU/ft
90 - 4	324.6
120 - 4	434.4
160 - 5	579.0
200 - 6	720.6
240 - 7	868.8
280 - 8	1013.4

Tab. 3 Gas flow rate (based on gas temperature of 60 °F and air pressure of 30 in. Hg)

The boiler is factory-set for: – Natural gas

Note:

- This series of boiler is not available for LP (Liquid Propane)
- There is no field retrofit kit available to convert this series boiler to LP gas

2 Installing the boiler

2.1 Recommended wall clearances

When deciding on the installation site, the clearances for the flue piping and the connecting pipes must be observed (□Fig. 9 and Section 5.1, Connecting the flue system and water and gas piping).

Dimension	Wall clearance (inch)	
	minimum	Recommended
A	20	28
B ¹⁾	22	28
C	20	28
D	20	28
E ¹⁾	6	14

Tab. 4 Recommended and minimum wall clearances (dimensions in inches). It is imperative that the minimum clearance (dimension E) is maintained.

1) This clearance dimension is dependent on the flue system fitted



Where applicable, allow extra wall clearances for additional components such as DHW tank, pipe connections or other flue components, etc.

Notes: (multiple boiler installations)

- A.** Minimum clearance between boilers
- Refer to "D" dimension for side by side installations
 - Refer to "B" and "E" dimension for back to back installations
- B.** See Table 4 for all other clearance dimensions.

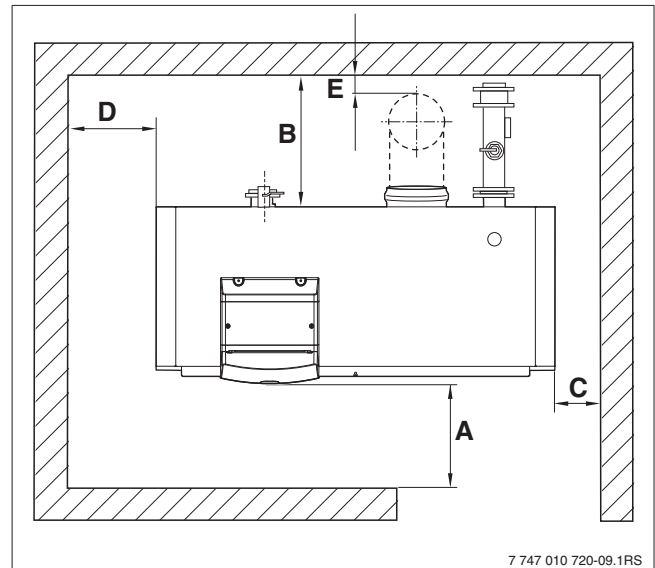

Fig. 5 Wall clearances in the boiler room

2.2 Leveling the boiler

To prevent air collecting in the boiler and to allow the condensate to drain freely from the condensate pan, the boiler must be leveled.



Caution: Risk of boiler damage due to inadequate load-bearing capacity of floor or unsuitable base.

- Make sure that the surface on which the boiler stands has sufficient load-bearing capacity.
 - The boiler may stand on a base made of combustible material but not on carpet.
-
- Place the boiler in its final position.
 - Level the boiler horizontally by turning the adjustable feet and using a spirit level.

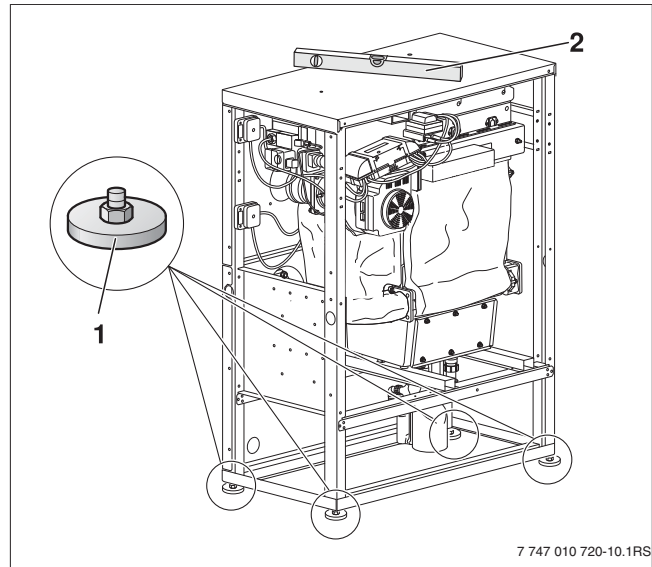

Fig. 6 Leveling the boiler

- 1 Adjustable feet
- 2 Spirit level

3 Water quality requirements

Poor water quality can damage heating systems due to scale formation and corrosion.

About this chapter:

This operator's log contains important information regarding the treatment of water for boilers containing aluminium materials.

This document shows you how to keep a log of water treatment. It explains with the aid of an example how to make the necessary calculations and record the figures. A record book table is included at the end of this chapter. This operator's log is intended for the system user as well as qualified heating engineers, who – as a result of their training and experience – are skilled in dealing with heating systems.

Warranty claims in respect of GB312 boilers are only valid in conjunction with the requirements specified herein and properly completed annual service records in the operator's log and the servicing and maintenance log.

3.1 Maintenance of user manual

In addition to the quantity of first-fill and replenishment water added to the system, you should also record its calcium carbonate [CaCO₃] concentration (hardness) in this log book (See page 15).

3.2 Prevention of damage by corrosion

Additional protection against corrosion

Corrosion damage occurs if oxygen constantly enters the heating water due, for example, to:

- undersized expansion vessels
- faulty expansion vessels
- open-vented systems.

If the system cannot be constructed as a sealed system, anti-corrosion measures such as system separation by means of a heat exchanger are necessary.



USER NOTE

- If the appliance is installed in an existing heating system, dirt may accumulate in the boiler, leading to localized overheating, corrosion and noise.
- Always install a WYE-STRAINER in existing heating systems.

Installing a dirt trap like an WYE-strainer and a desludging device is required. This must be installed in the heating system in the immediate vicinity of the boiler, in an easily accessible position between the boiler and the lowest point in the return of the system, and cleaned at every annual service.

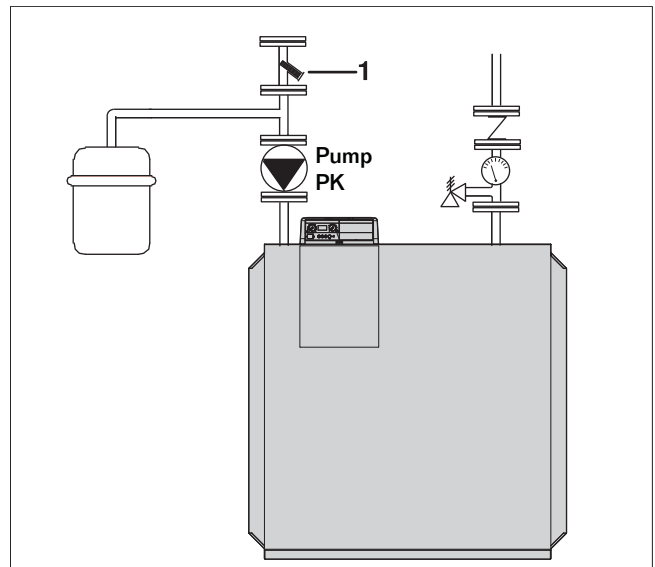

Fig. 7 WYE Strainer location

1 WYE Strainer

3.3 Water hardness

Use only clean municipal water to fill the system. In order to protect the appliance against limescale damage over its entire service life and in order to ensure trouble-free operation, the total amount of limescale-forming substances in the first-fill and replenishment water used in the heating system must be limited.

3.4 Checking the maximum quantity of first-fill water based on water quality



USER NOTE

If the system capacity exceeds the calculated allowable water volume V_{\max} , damage to the boiler can result.

To check the permissible water quantities based on water quality, either use the following calculation methods or consult the graphs.

Calculation basis

The first-fill and replenishment water has to meet certain requirements that are dependent on the total boiler output and the resulting total volume of water in the heating system. Use the following formula to calculate the maximum quantity of fill water that may be introduced without treatment:

$$V_{\max} (\text{ft}^3) = 0.0243 \times \frac{Q_{\text{out}} (\text{Btu/h})}{\text{CaCO}_3 (\text{ppm})}$$

Formula for calculating the maximum quantity of (untreated) water that may be introduced

V_{\max} = maximum volume of untreated first-fill and replenishment water in ft^3 that may be introduced into the system over the entire service life of the boiler (1 ft^3 = 7.48 gallon)

Q_{out} = Total boiler output in Btu/h (see Tab. 1)

CaCO_3 = Calcium carbonate concentration (hardness) in ppm (1 ppm = 1 mg/l)

Information about the calcium carbonate (CaCO_3 , hardness) concentration of the municipal water can be obtained from your local water company.

Example calculation:

Calculation of the maximum permitted quantity of first-fill and replenishment water, V_{\max} , for a heating system with a total boiler output of 955,400 Btu/h (boiler size 280–8). Water hardness analysis figures quoted in ppm (CaCO_3).

$Q_{\text{out}} = 955,400 \text{ Btu/h}$
Hardness (CaCO_3) = 280 ppm

Maximum permissible water volume V_{\max}

$$V_{\max} = 0.0243 \times \frac{955,400 \text{ Btu/h}}{280 \text{ ppm}} = 83 \text{ ft}^3$$

Boiler size	Boiler output Q_{out} [Btu/h] 122/86°F
90-4	307,090
120-4	409,460
160-5	545,940
200-6	682,430
240-7	818,910
280-8	955,400

Tab. 5 Boiler output

3.5 pH requirements

- The optimal range of pH for the boiler system fluid is 7.0 to 8.5.
- pH must be checked and recorded at each yearly maintenance in order to keep the warranty valid.
- Failure to do so will immediately void the warranty on the heat exchanger
- Adjusting pH if it is out of range (7.0pH to 8.5pH)
 - Flush system with fresh municipal water, run the system up to temperature for an hour and check pH.
 - OR
 - Add Rhomar Protek 922 to the system at a volume of 1 gallon of Protek 922 to 25 gallons of system volume.

Limit curves

As an alternative to calculation, the V_{max} figure may be taken from the following graphs.

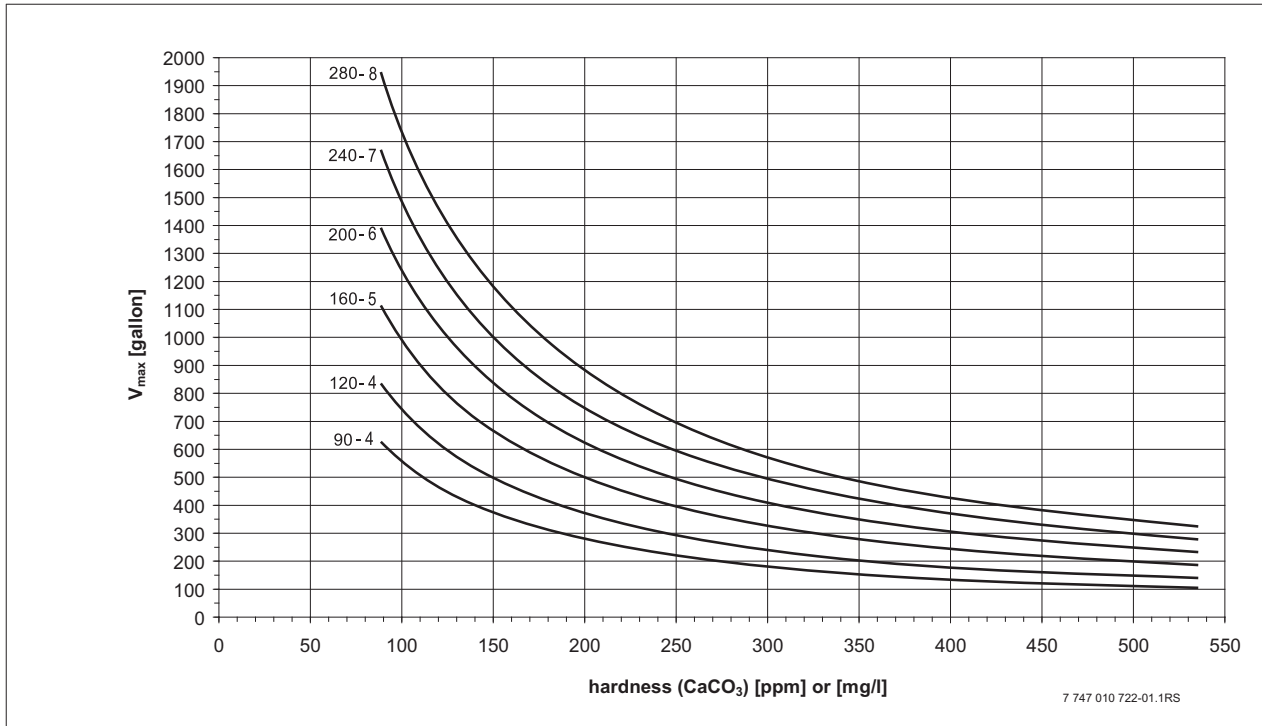

Fig. 2 Water treatment limit curves for the various boiler sizes

The rule for V_{max} is:

Above the limit curve = water treatment necessary

Below the limit curve = no water treatment necessary

(Units: $1\text{ft}^3 = 7.48$ gallon, $1\text{ppm} = 1\text{mg/l}$, $1\text{grain/gal} = 17.1\text{ ppm or mg/l}$)



USER NOTE

Any additives introduced into the heating system water must be approved by the manufacturer for use with aluminum boilers.

When is water treatment necessary?

- If the quantity of fill water actually needed is less than V_{max} , untreated water may be introduced.
- If the quantity of fill water actually needed is more than V_{max} , water treatment is necessary.
- To reduce the amount of scale, the two approved additives Noble Company Noburst AL and Rhomar RhoGard may be used (these products are also used as antifreeze). They can reduce the amount of scale introduced by the fill water by 50% and 60% respectively.
- Do not use water from salt bedding type exchangers (ion exchanger) used to soften water.

Buderus

3.6 Operator's log

Details of GB312 heating system: _____
Date commissioned: _____
Max. water volume V_{max} : _____ gal at **CaCO₃ concentration of** _____ ppm
Anti freeze product used? Rhomar Rho Gard (50-60% Concentration): Noble Company Noburst AL (50% Concentration):

	Date	Water volume untreated (measured) gal	CaCO ₃ - concentrati- on ppm	Total water volume untreated gal	Concentration of anti- freeze in system %	Company (stamp) Signature
Total fill water in gal						
Added water in gal						

4 Openings for combustion air supply and venting

To ensure an adequate combustion air supply and venting of the heating system, suitable measures must be taken in accordance with the National Fuel Gas Code, NFPA 54 (ANSI Z223.1), Section 5.3, Air for Combustion and Ventilation, or the local building code. In Canada the regulations in accordance with CAN/CSA B 149.1 and 2 Installation Codes apply.



Caution: Risk of boiler damage and malfunctions due to missing or inadequate openings for combustion air and venting of the boiler room.

The openings for combustion air supply and venting are always required regardless of whether the combustion air is drawn from the room (conventional flue) or supplied directly to the boiler through ducts (balanced flue). Inadequate venting of the boiler room may result in excessive ambient temperatures. This can damage the boiler. Inadequate combustion air supply may cause malfunctions in operation.

- Make sure that air inlet or outlet vents are not closed off or their size reduced and that they are adequately dimensioned.
- The boiler must not be operated until the obstruction has been removed.
- Draw the operator's attention to any deficiencies and the potential dangers.



Caution: Risk of boiler damage from contaminated combustion air.

- Never use cleaning agents that contain chlorine or halogenated hydrocarbons (e.g. in spray cans, solvents and cleaning agents, paints, glues).
- Do not store or use such substances in the boiler room.
- Avoid excessive dust accumulation.



If impurities in the combustion air are possible (e.g. installation near swimming pools, dry cleaners or hairdressing salons), operation independent of room air is recommended.



Caution: Dangers posed by explosive and easily combustible materials.

- Do not use or store easily combustible materials (paper, lace curtains, clothing, thinners, paints, etc.) near the boiler.
- Maintain a clearance of 16 inches from the boiler.

Overall air supply within the building

Make sure that the boiler room has two permanent air vents that are connected to one or more other rooms. When calculating the cross-sectional areas of the vent apertures, the total burner output of all gas-fired appliances in the connected rooms must be taken into account. Each vent must have a minimum cross-section of one square inch per 1000 Btu/h of the total burner output of all gas-fired appliances inside the connected rooms. Make sure that the cross-sectional area of each vent is at least 100 square inches. One of the vents must be no more than 12" from the ceiling and the other no more than 12" from the floor of the boiler room, measured from the outer edge of the vent aperture. The smallest dimension of all inlet and outlet vents must be not less than 3".

Total air supply from outside the building

Make sure that the boiler room has two permanent air vents, one of which must not be more than 12" from the ceiling and the other not more than 12" from the floor of the boiler room, measured from the outer edge of the vent aperture. The vents must be connected either directly or via air ducts to the outside or to rooms that have an unobstructed connection to the open air (crawl passage or roof space). The smallest dimension of all inlet and outlet vents must be not less than 3"

- If there is a direct connection to the outside, each opening must have a minimum cross-section of one square inch per 4000 Btu/h of the total combustion output of all gas-fired appliances inside the closed room.
- If there is a connection to the outside through a ventilated attic with vertical ventilation ducts, each vent aperture must have a minimum cross-section of one square inch per 4000 Btu/h of the total burner output of all gas-fired appliances inside the closed room. The attic must be ventilated at both ends of the house.
- If there is a connection to the outside through horizontal ventilation ducts, each vent aperture must have a minimum cross-section of one square inch per 2000 Btu/h of the total burner output of all gas-fired appliances inside the closed room. The duct cross sectional area must not be smaller than the free area of the inlet.
- If there is a connection to the outside through a ventilated attic and ventilated crawl space, each opening must have a minimum cross-section of one square inch per 4000 Btu/h. The attic must be ventilated at both ends of the house.

5 Venting requirements

This chapter details how to install the boiler. The steps are:

- Exhaust and air supply system
- Heating circuit connection
- Connecting the fuel supply
- Making the electrical connections

General notes

The boiler requires a flue system approved for Category IV (condensing, positive pressure; to ANSI Z21.13/ CSA4.9). The material must consist of 316L or AL 29-4C stainless steel and conform to UL 1738 or UL 103.

In Canada, flue system material must conform to ULC-636.

We recommend flue systems made by the following manufacturers:

Stainless steel flue system for U.S.A and Canada			Table 6
Manufacturer	Flue System	AL29-4C Starter Adapter Part No.	
Heatfab	Saf-T Vent EZ Seal	GB312/90 to GB312/160 = 9601GB ADAPTER (6" nominal size)	
		GB312/200 to GB312/280 = 9801GB ADAPTER (8" nominal size)	
Z-Flex	Z-Vent IV special gas vent	GB312/90 to GB312/160 = 2SVSGBA06 (6" nominal size)	
		GB312/200 to GB312/280 = 2SVSGBA08 (8" nominal size)	
Metal Fab	Corr Gaurd	GB312/90 to GB312/160 = 6CFGBA (6" nominal size)	
		GB312/200 to GB312/280 = 8CFGBA (8" nominal size)	
Pro-Tech	Fasnseal	GB312/90 to GB312/160 = FSA-GB312-6 (6" nominal size)	
		GB312/200 to GB312/280 = FSA-GB312-8 (8" nominal size)	
Security Chimney	CI-System	GB312/90 to GB312/160 = tbd (6" nominal size)	
		GB312/200 to GB312/280 = tbd (8" nominal size)	

CPVC flue system for U.S.A only				Table 7
CPVC Manufacturer	Specification	Manufacturer	CPVC Starter Adapter Part No.	
Spears	CPVC pipe to	Heatfab	GB312/90 to GB312/160 = 96GBCPVC ADAPTER (6" nominal size)	
	Schedule 80 ASTM D1784		GB312/200 to GB312/280 = 98GBCPVC ADAPTER (8" nominal size)	
		Z-Flex	GB312/90 to GB312/160 = 2SVSGBP06 (6" nominal size)	
			GB312/200 to GB312/280 = 2SVSGBP08 (8" nominal size)	
		Metal Fab	GB312/90 to GB312/160 = 6CGBPA (6" nominal size)	
			GB312/200 to GB312/280 = 8CGBPA (8" nominal size)	
		Pro-Tech	GB312/90 to GB312/160 = FSA-GB312-6-PVCF (6" nominal size)	
			GB312/200 to GB312/280 = FSA-GB312-8-PVCF (8" nominal size)	
		Security Chimney	GB312/90 to GB312/160 = tbd (6" nominal size)	
			GB312/200 to GB312/280 = tbd (8" nominal size)	

Note: Please contact the manufacturers listed above to order.

If a plastic system (CPVC) is used in Canada, it must be approved as a type "BH gas venting system" (ULC S636).

The components, adhesives and adhesive primers specified by the flue system manufacturer must be used. Only components, adhesives, adhesive primers, etc. made by the same manufacturer may be used.

The following flue system is approved for use in Canada:

CPVC flue system for Canada		Table 8
Manufacturer	Flue System	
IPEX*	System 636 CPVC	

* This system is only available up to 4" size & only applies to GB312/90 for 55ft TEL or the GB312/120 for 30ft TEL.

Flue/air supply system installation must comply with Part 10, Venting of Equipment, of the National Fuel Gas Code NFPA 54 (ANSI Z223.1), or CAS B.149 or other applicable local building code regulations.

The flue and air supply system (for design of air supply connection □ Section 5.5) must be designed for a max. pressure of 0.40 inches W.C. (100 Pa) for the overall system (exhaust and air supply system).

Observe the following points when installing the flue ducting:

- The cross-sectional area of the flue pipe must be calculated according to the applicable regulations.
- Select the shortest possible route for the exhaust pipe.
- Install flue pipes with an upward slope from the boiler ($\frac{1}{4}$ " per foot minimum).

We recommend the fitting of a protective grille (bird screen) to the flue pipe terminal.

For details of correct dimensioning, contact the venting manufacturer concerned providing a complete sizing dimensions of the venting system.



All instructions relating to all parts of the flue system, and especially the instructions of the flue system manufacturer, must be followed. Use only flue pipes with the appropriate diameter for the output rating of the boiler and made by the recommended manufacturers listed in Table 6, 7 or 8.

Flue system for multi-boiler systems (cascading systems)

These instructions relate only to single-boiler systems. Flue/air supply systems for multi-boiler systems must be designed by qualified heating engineers and approved and guaranteed by the flue system manufacturer. The flue system must prevent back-flow of flue gas through boilers that are not in operation.



In the case of exhaust systems sealed with silicon from a cartridge, the silicon must be allowed to cure for 24 hours before commissioning the boiler.



Danger: Risk of fatal injury from escaping flue gases in the boiler room.

- The seal in the condensate pan flue connection must be present, undamaged and correctly inserted.
- Fitting a barometric damper in the flue system is not permitted.



Caution: Risk of system damage due to inadequate condensate drainage.

- The condensate that forms in the flue pipe must be drained away from the boiler via the condensate drain on the condensate pan.
- Always use a condensate neutralizer.
- Provide periodic maintenance to the condensate drain piping and neutralizer system to ensure proper operation.



Caution: Risk of system damage due to inadequate condensate drainage.

- **In high temperature applications it is necessary to use mineral oil in the condensate trap to maintain a trap seal so CO gases do not escape into the boiler room.**



Caution: Disruption of operation due to high wind.

If no T-piece or 90° downward-turned elbow is fitted on the end of flue pipe, high winds may cause the boiler to shut down.

- Always make sure that there is a T-piece or a 90° downward-turned elbow fitted depending on the design of the flue system.
- Use only a T-piece or 90° downward-turned elbow (Category IV) made by the selected flue system manufacturer.



With regard to possible restrictions and inspections for flue systems, consult the local building and fire safety authorities. Observe the national regulations.

In the Commonwealth of Massachusetts the legal requirements concerning the installation and maintenance of carbon monoxide detectors must be followed.



Danger: Risk of fatal injury due to poisoning by escaping flue gas.

- After carrying out any of the installation instructions referred to, check that all connections throughout the entire flue system are properly joined and sealed.
- Check seams and joints for leaks.
- Have the entire flue system checked once a year by a qualified heating contractor.

5.1 Connecting the air supply (for direct vent operations)

The combustion air is supplied to the boiler either through an external wall connection, through a chimney flue or through a separate pipe in the chimney flue. For balanced flue operation, a suitable air supply system must be used (made of PVC or CPVC, or galvanized steel). The flue and air supply system (for design of flue connection □ Section 6, page 21) must be designed for a max. pressure of 0.40 inches W.C. for the overall system (exhaust and air supply system).



We recommend that the air supply pipe diameter matches the flue pipe diameter.

Boiler rating	Required air supply volumetric flow rate [ft ³ /min]	Recommended air supply pipe diameter [inches]
90 - 4	95	5
120 - 4	95	6
160 - 5	130	6
200 - 6	160	8
240 - 7	190	8
280 - 8	220	8

Tab.9 Air supply volumetric flow rate/Air supply pipe diameter

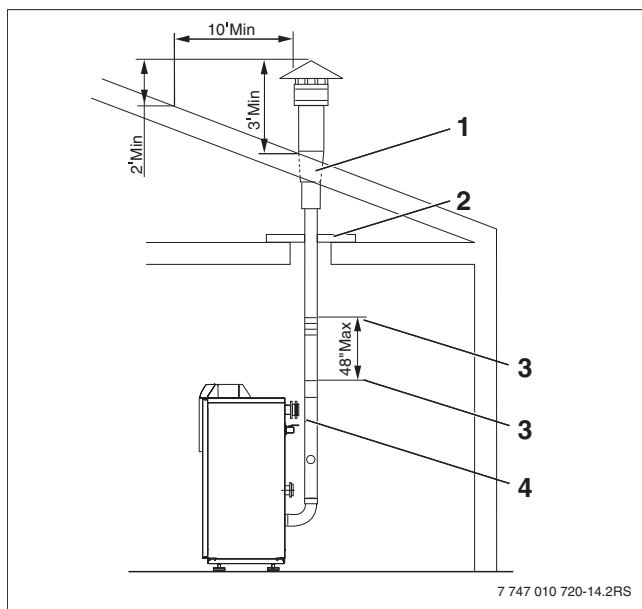

Fig. 9 Vertical flue system

- 1 Roof penetration
- 2 Fire protection collar
- 3 Fastening the flue pipe
- 4 Flue pipe adaptor (available separately)

- Remove the side panel if not already removed.
- Unscrew the cover plate from the rear panel.

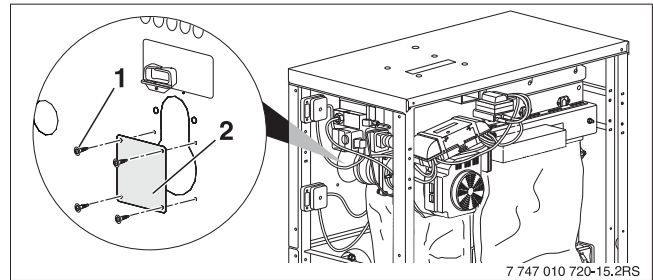

Fig. 10 Connecting the air supply for balanced flue operation

- 1 Screw
- 2 Cover plate



Use a 90° elbow for the combustion air inlet at the entrance to the boiler to avoid an interference with the gas connection.

- Connect the air pipe 90° elbow to the air pipe socket through the rear panel and seal.
- Construct the air supply pipe using a standard air pipe system according to the national requirements.
- After making the connection at the boiler, increase air supply pipe to sizes shown in Table 9 external to boiler

We recommend the fitting of a protective grille (bird screen) to the air pipe terminal. For details of correct dimensioning, contact the manufacturer concerned.

5.2 Installing the wall exit for air supply pipe

To prevent possible recirculation of exhaust gas, the exhaust system installer must take account of effects such as the prevailing wind conditions, any eddy zones, the specifics of the site, etc. in the design of the flue and air supply systems. Buderus can not be held responsible for such potentially detrimental effects on boiler operation. The clearances detailed or illustrated in Fig. 12 and Fig. 16 should be seen as the absolute minimum and may in some circumstances not be adequate for specific installations.

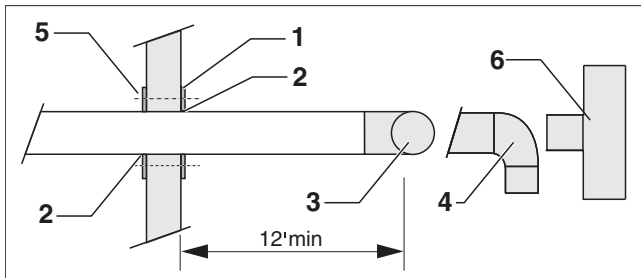

Fig. 11 Design of air supply or exhaust pipe wall exit

- 1 Outer wall retaining plate
- 2 Sealant
- 3 T-piece or 4) 90° elbow
- 4 90° elbow - down turned
- 5 Inner wall centering and retaining plate
- 6 Tee termination (optional)



Contact vent pipe manufacturer for installation guidelines to support vertical lengths of pipe.

Note: For exhaust applications, the distance for clearance to combustible must be maintained. Refer to NFPA54 (ANSI Z223.1) for details.

5.3 Installing the roof exit for air pipe

To prevent possible recirculation of flue gas, the flue system installer must take account of effects such as the prevailing wind conditions, any eddy zones, the specifics of the site, etc. in the design of the flue and air supply systems. Buderus can not be held responsible for such potentially detrimental effects on boiler operation. The clearances detailed or illustrated should be seen as the absolute minimum and may in some circumstances not be adequate for specific installations.

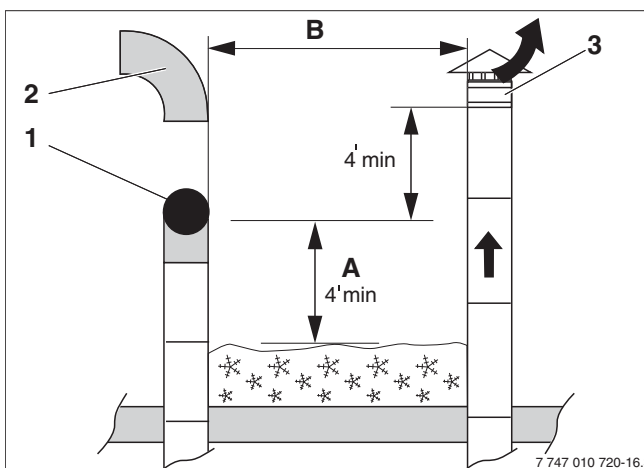

Fig. 12 Design of air pipe roof exit

- 1 T-piece or 2) 90° elbow
- 3 Flue outlet
- B Minimum horizontal distance from air intake of another appliance = 10 ft, minimum distance from own air intake for directly vented appliances = 4 ft.

5.4 Design of flue and air pipe for balanced flue operation (refer to NFPA54 ANSIZ223.1 for dimensions)

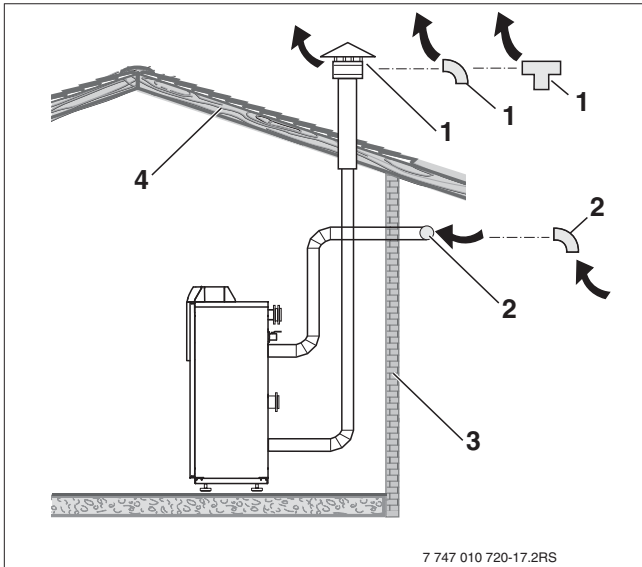

Fig. 13 Wall-exit air supply pipe, roof-exit exhaust

- 1 Flue outlet (type of outlet depends on chosen manufacturer, e.g. 90° elbow or T-piece) See Fig. 9.
- 2 Air inlet (T-piece fitted horizontally or 90° elbow)
- 3 External wall
- 4 Roof

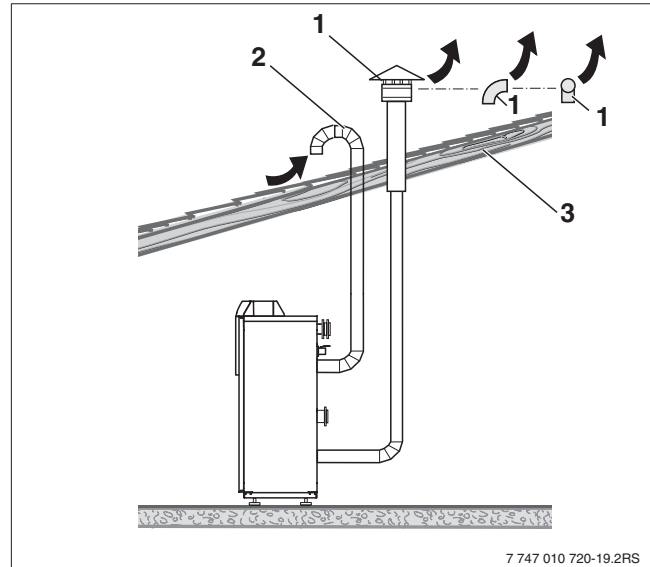

Fig. 15 Roof-exit air supply pipe and exhaust

- 1 Flue outlet (type of outlet depends on chosen manufacturer, e.g. 90° elbow or T-piece), observe clearances specified in Fig. 5
- 2 Air inlet terminal (90° elbow pointing away from flue outlet)
- 3 Roof

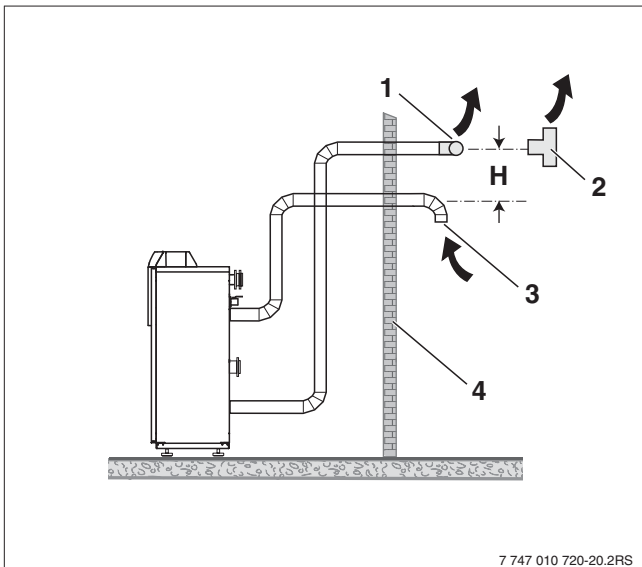

Fig. 14 Wall-exit air supply pipe and exhaust

- 1;2 Flue outlet (external-wall flue requires horizontally or vertically mounted T-piece), observe clearances specified in Fig. 11
- 3 Air intake terminal (90° elbow facing vertically downwards)
- 4 External wall
- H Refer to NFPA54, ANSIZ223.1 National Fuel Gas Code for details

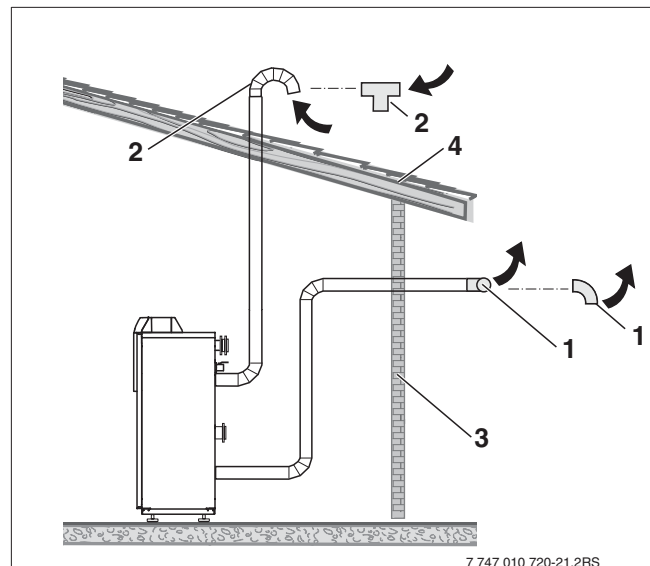

Fig. 16 Roof-exit air supply pipe, wall-exit exhaust

- 1 Flue outlet (external-wall flue requires horizontally mounted T-piece or 90° elbow facing downwards)
- 2 Air inlet (90° elbow or T-piece)
- 3 External wall
- 4 Roof

5.5 Venting system calculation/sizing chart

GB312 are Cat. IV positive pressure, induced draft condensing gas boilers

Note:

Total equivalent lengths in tables 10, 11 and 12 are guidelines and for reference only. Please contact chimney manufacturer directly for specific chimney design.

Calculation example

Calculate the vent pipe and combustion air pipe for the following:

Vertical vent and vertical combustion air pipe

vent pipe:

- 1 each - 90 degree elbow = 7ft equivalent length
- 1 each - rain cap = 10ft equivalent length
- 68 lineal feet of pipe = 68ft equivalent length
- Total = 85ft total equivalent length

combustion air pipe:

- 3 each - 90 degree elbow = 21ft equivalent length
- 1 each - inlet termination = 10ft equivalent length
- 50 lineal feet of pipe = 50ft equivalent length
- Total = 81ft total equivalent length

What size vent (exhaust) pipe is needed? 5" diameter
What size combustion air pipe is needed? 5" diameter

5.5.1 Vertical Vent and Vertical Combustion Air Inlet (Natural Gas)
 (See Figure 15)

Operating Conditions:

- Total flue & combustion air supply system pressure: 0.40"WC
 - Vent calculated on 0.2" WC
 - Combustion air calculated on 0.2" WC
- Min. Gross Stack Temp: 150 F
- CO2 percentage: NG: 9 %

Venting Parameters:

- Exhaust horizontal: termination tee
- Exhaust vertical: rain cap
- Sealed Comb. Intake (all models): PVC piping with 90° downward elbow
- 90° elbow = 7ft equivalent length
- 45° elbow = 4ft equivalent length
- Rain cap termination = 10ft equivalent length
- 1 lineal foot of pipe = 1ft equivalent length

GB312 Venting System Table		Vent (Exhaust) Outlet Vertical			Table 10	
Models	Input (MBH)	Vent Connection at Boiler	Venting Diameter (inches)	Total Equivalent Length of Vent (max)	Vent Diameter for (minus one) size diameter and TEL in feet	Vent Diameter for (minus two) size diameter and TEL in feet
GB312-90	328	6"	6"	100	5" = 100ft	4" = 55ft
GB312-120	440	6"	6"	100	5" = 80ft	4" = 30ft
GB312-160	588	6"	6"	100	5" = 50ft	4" = NA
GB312-200	733	8"	8"	100	7" = 100ft	6" = 70ft
GB312-240	881	8"	8"	100	7" = 100ft	6" = 55ft
GB312-280	1029	8"	8"	100	7" = 100ft	6" = 35ft

GB312 Venting System Table		Combustion Air (inlet) Vertical				
Models	Input (MBH)	Combustion Air Inlet Connection at Boiler	Combustion Air Pipe Diameter (inches)	Total Equivalent Length of Combustion Air Pipe (max)	Combustion Air Pipe Diameter (minus one inch) maximum TEL in feet	Combustion Air Pipe Diameter (minus two inch) maximum TEL in feet
GB312-90	328	4"	5"	100	4" = 55ft	3" = NA
GB312-120	440	4"	6"	100	5" = 95ft	4" = 30ft
GB312-160	588	4"	6"	100	5" = 50ft	4" = NA
GB312-200	733	4"	8"	100	7" = 100ft	6" = 70ft
GB312-240	881	4"	8"	100	7" = 100ft	6" = 55ft
GB312-280	1029	4"	8"	100	7" = 100ft	6" = 35ft

Note: Breeching pressure measured at outlet of boiler vent connection.

Buderus

5.5.2 Vertical Vent and Horizontal Combustion Air Inlet (Natural Gas) (See Figure 13)

Operating Conditions:

- Total flue & combustion air supply system pressure: 0.40"WC
 - Vent calculated on 0.2" WC
 - Combustion air calculated on 0.2" WC
- Min. Gross Stack Temp: 150 F
- CO2 percentage: NG: 9 %

Venting Parameters:

- Exhaust horizontal: termination tee
- Exhaust vertical: rain cap
- Sealed Comb. Intake (all models): PVC piping with 90° downward elbow
- 90° elbow = 7ft equivalent length
- 45° elbow = 4ft equivalent length
- Rain cap termination = 10ft equivalent length
- 1 lineal foot of pipe = 1ft equivalent length

GB312 Venting System Table		Vent (Exhaust) Outlet Vertical			Table 11	
Models	Input (MBH)	Vent Connection at Boiler	Venting Diameter (inches)	Total Equivalent Length of Vent (max)	Vent Diameter for (minus one) size diameter and TEL in feet	Vent Diameter for (minus two) size diameter and TEL in feet
GB312-90	328	6"	6"	100	5" = 100ft	4" = 55ft
GB312-120	440	6"	6"	100	5" = 80ft	4" = 30ft
GB312-160	588	6"	6"	100	5" = 50ft	4" = NA
GB312-200	733	8"	8"	100	7" = 100ft	6" = 70ft
GB312-240	881	8"	8"	100	7" = 100ft	6" = 55ft
GB312-280	1029	8"	8"	100	7" = 100ft	6" = 35ft

GB312 Venting System Table		Combustion Air (inlet) Horizontal				
Models	Input (MBH)	Combustion Air Inlet Connection at Boiler	Combustion Air Pipe Diameter (inches)	Total Equivalent Length of Combustion Air Pipe (max)	Combustion Air Pipe Diameter (minus one inch) maximum TEL in feet	Combustion Air Pipe Diameter (minus two inch) maximum TEL in feet
GB312-90	328	4"	5"	100	4" = 40ft	3" = NA
GB312-120	440	4"	6"	100	5" = 75ft	4" = NA
GB312-160	588	4"	6"	100	5" = NA	4" = NA
GB312-200	733	4"	8"	100	7" = 100ft	6" = 45ft
GB312-240	881	4"	8"	100	7" = 100ft	6" = NA
GB312-280	1029	4"	8"	100	7" = 100ft	6" = NA

Note: Breeching pressure measured at outlet of boiler vent connection.

5.5.3 Horizontal Vent and Horizontal Combustion Air Inlet (Natural Gas) (See Figure 14)

Operating Conditions:

- Total flue & combustion air supply system pressure: 0.40"WC
 - Vent calculated on 0.2" WC
 - Combustion air calculated on 0.2" WC
- Min. Gross Stack Temp: 150 F
- CO2 percentage: NG: 9 %

Venting Parameters:

- Exhaust horizontal: termination tee
- Exhaust vertical: rain cap
- Sealed Comb. Intake (all models): PVC piping with 90° downward elbow
- 90° elbow = 7ft equivalent length
- 45° elbow = 4ft equivalent length
- Rain cap termination = 10ft equivalent length
- 1 lineal foot of pipe = 1ft equivalent length

GB312 Venting System Table		Vent (Exhaust) Outlet Horizontal			Table 12	
Models	Input (MBH)	Vent Connection at Boiler	Venting Diameter (inches)	Total Equivalent Length of Vent (max)	Vent Diameter for (minus one) size diameter and TEL in feet	Vent Diameter for (minus two) size diameter and TEL in feet
GB312-90	328	6"	6"	100	5" = 100ft	4" = 40ft
GB312-120	440	6"	6"	100	5" = 75ft	4" = NA
GB312-160	588	6"	6"	100	5" = NA	4" = NA
GB312-200	733	8"	8"	100	7" = 100ft	6" = 45ft
GB312-240	881	8"	8"	100	7" = 100ft	6" = NA
GB312-280	1029	8"	8"	100	7" = 65ft	6" = NA

GB312 Venting System Table		Combustion Air (inlet) Horizontal				
Models	Input (MBH)	Combustion Air Inlet Connection at Boiler	Combustion Air Pipe Diameter (inches)	Total Equivalent Length of Combustion Air Pipe (max)	Combustion Air Pipe Diameter (minus one inch) maximum TEL in feet	Combustion Air Pipe Diameter (minus two inch) maximum TEL in feet
GB312-90	328	4"	5"	100	4" = 40ft	3" = NA
GB312-120	440	4"	6"	100	5" = 75ft	4" = NA
GB312-160	588	4"	6"	100	5" = NA	4" = NA
GB312-200	733	4"	8"	100	7" = 100ft	6" = 45ft
GB312-240	881	4"	8"	100	7" = 100ft	6" = NA
GB312-280	1029	4"	8"	100	7" = 65ft	6" = NA

Note: Breeching pressure measured at outlet of boiler vent connection

5.5.3 Horizontal Vent and Vertical Combustion Air Inlet (Natural Gas) (See Figure 16)

Operating Conditions:

- Total flue & combustion air supply system pressure: 0.40"WC
 - Vent calculated on 0.2" WC
 - Combustion air calculated on 0.2" WC
- Min. Gross Stack Temp: 150 F
- CO2 percentage: NG: 9 %

Venting Parameters:

- Exhaust horizontal: termination tee
- Exhaust vertical: rain cap
- Sealed Comb. Intake (all models): PVC piping with 90° downward elbow
- 90° elbow = 7ft equivalent length
- 45° elbow = 4ft equivalent length
- Rain cap termination = 10ft equivalent length
- 1 lineal foot of pipe = 1ft equivalent length

GB312 Venting System Table		Vent (Exhaust) Outlet Horizontal			Table 13	
Models	Input (MBH)	Vent Connection at Boiler	Venting Diameter (inches)	Total Equivalent Length of Vent (max)	Vent Diameter for (minus one) size diameter and TEL in feet	Vent Diameter for (minus two) size diameter and TEL in feet
GB312-90	328	6"	6"	100	5" = 100ft	4" = 40ft
GB312-120	440	6"	6"	100	5" = 75ft	4" = NA
GB312-160	588	6"	6"	100	5" = NA	4" = NA
GB312-200	733	8"	8"	100	7" = 100ft	6" = 45ft
GB312-240	881	8"	8"	100	7" = 100ft	6" = NA
GB312-280	1029	8"	8"	100	7" = 65ft	6" = NA

GB312 Venting System Table		Combustion Air (inlet) Vertical				
Models	Input (MBH)	Combustion Air Inlet Connection at Boiler	Combustion Air Pipe Diameter (inches)	Total Equivalent Length of Combustion Air Pipe (max)	Combustion Air Pipe Diameter (minus one inch) maximum TEL in feet	Combustion Air Pipe Diameter (minus two inch) maximum TEL in feet
GB312-90	328	4"	5"	100	4" = 55ft	3" = NA
GB312-120	440	4"	6"	100	5" = 95ft	4" = 30ft
GB312-160	588	4"	6"	100	5" = 50ft	4" = NA
GB312-200	733	4"	8"	100	7" = 100ft	6" = 70ft
GB312-240	881	4"	8"	100	7" = 100ft	6" = 55ft
GB312-280	1029	4"	8"	100	7" = 65ft	6" = 35ft

Note: Breeching pressure measured at outlet of boiler vent connection

6 Piping the boiler

6.1 Connecting central heating supply

- Fit and seal the heating system supply pipe to the threaded flange supplied.
- Insert the seal in the flange joint and tighten the bolts evenly.
- Boiler warranty is null and void unless the check valve is properly installed and maintained in conjunction with supply manifold

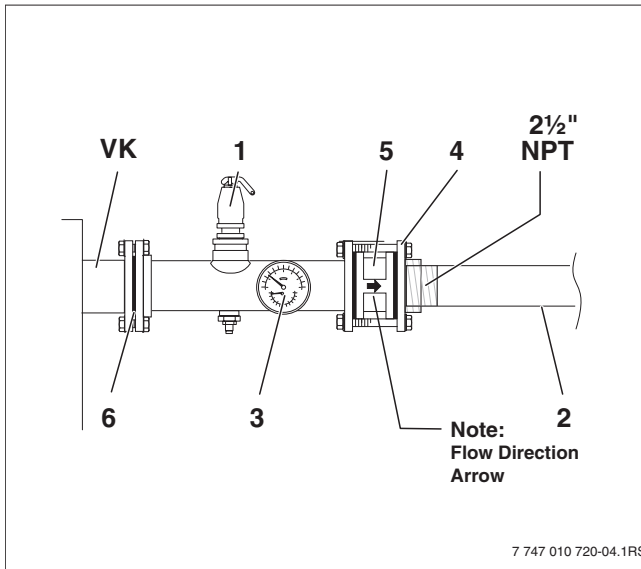

Fig. 17 Fitting the B-kit and supply pipe

- 1 Pressure relief valve
- 2 Supply pipe (external with NPT thread)
- 3 Pressure/temperature gauge
- 4 Threaded flange - 2 1/2" NPT female
- 5 Check valve (observe direction of flow →)
- 6 Gasket
- VK Boiler supply

B-Kit Parts list	
Quantity	Description
1	Supply Manifold
4	2 1/2" Pipe Size Gaskets
1	Check Valve
1	Pressure and Temperature Gauge
1	Relief Valve - 50psi
12	Nuts - 5/8"
8	Bolts - 5/8" x 2 1/2" L
4	Bolts - 5/8" x 5" L
24	Washers - 5/8"
12	Lock Washers

6.2 Fitting the heating system return

- Fit and seal the heating system return pipe to the threaded flange supplied.
- Insert the seal in the flange joint and tighten the bolts evenly.

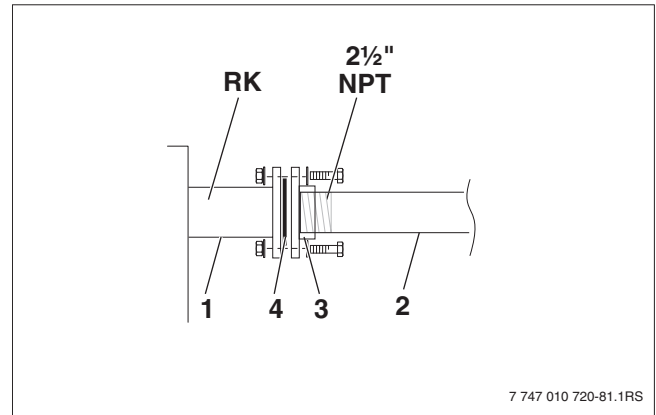

Fig. 18 Fitting the return pipe

- 1 Boiler return
- 2 Return pipe (external with NPT male thread)
- 3 Threaded flange - 2 1/2" NPT female
- 4 Gasket
- RK Boiler return

6.3 Installing the DHW Tank

A DHW Tank shall be piped as a separate zone of heat. (See piping and wiring schematics).

6.4 Installing the condensate drain



Notes on condensate drainage.

- The condensate that forms in the boiler and possible in the flue pipe must be properly drained away from the boiler.
- The condensate which forms in the flue pipe can be drained via the boiler (install flue pipe with downward slope towards the boiler).
- Make sure that drainage of the condensate into the public sewer system conforms with the applicable national regulations.
- Also observe any applicable local regulations.

- Remove the trap.
- Unscrew the cap and fill the trap with approx. 0.3 gallons of water.

Note: For high temperature applications add 1 cup of mineral oil to the trap



Danger: Risk of fatal injury from poisoning. If the trap is not filled with water or other connections are left open, escaping flue gas can place lives at risk.

- Fill the trap with water. (or mineral oil on high temperature applications)
- Seal the trap and flue connections.
- Make sure that the washer and seal are properly seated in the cap.

- Attach the trap.



Condensate may possibly escape through the trap vent hole.

- Be sure to run the drain pipe from the trap so that it slopes downwards.



Danger: Risk of fatal injury from poisoning.

- The boiler's internal trap must be used, make sure that the condensate from the flue system drains correctly.



A condensate neutralizer is available as an accessory. (Buderus part no. - NE0.1)

- Install the neutralizer according to the installation instructions.
- Fit the trap supplied to the condensate pan drain outlet.

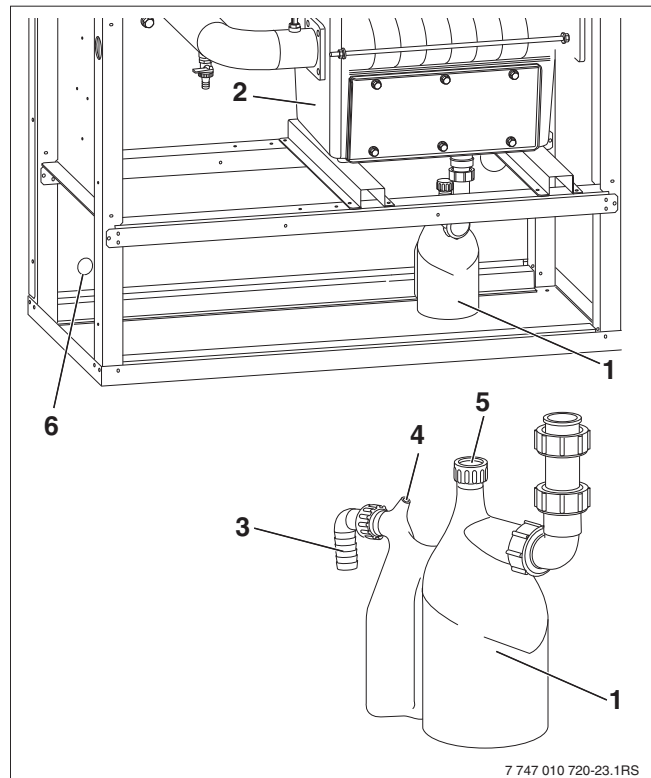

Fig. 19 Installing the condensate drain

- 1 Trap
- 2 Condensate pan
- 3 Trap outlet to neutralizer/waste pipe
- 4 Trap vent
- 5 Blanking cap
- 6 Hole for condensate drain hose

6.5 Connecting the fuel supply



Danger: Risk of fatal injury from the explosion of flammable gases.

- Work on gas components may only be carried out by qualified and authorized personnel.

6.5.1 Installing gas supply piping

For details of the required gas pipe diameter, refer to Tables on the following page. Make absolutely sure that the pipe fittings have the correct thread size.

- Make sure that a sediment trap is fitted at the inlet for the gas supply pipe to the boiler.



Fit and seal the gas isolating valve supplied to the boiler's gas connection.

- The gas pipes must be fastened outside the boiler and supported per code and standard plumbing practice.

Observe the local regulations or else the requirements the National Fuel Gas Code, ANSI Z 223.1 or CAN/CSA B149.1 in Canada, when connecting the gas supply.

Where required by local regulations, the installation must comply with the American Code for Controls and Safety Devices for Automatically Fired Boilers (ASME CSD-1). Accessories to comply with ASME CSD-1 are available.

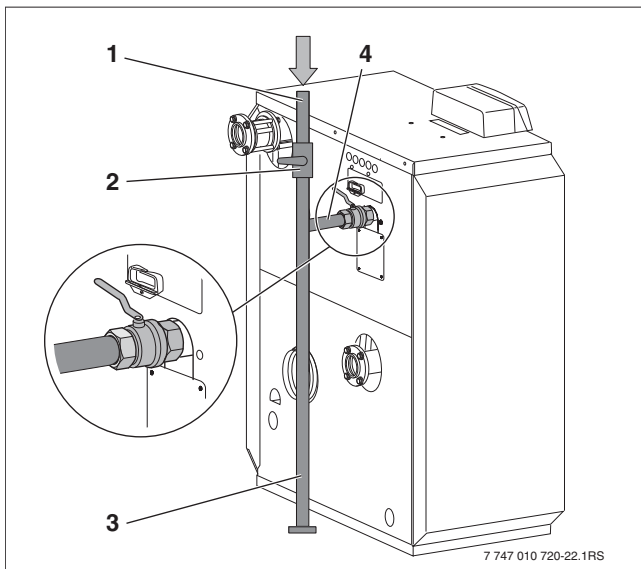

Fig. 20 Gas valve pipe connection

- 1 Gas supply
- 2 Manual shut-off valve (supplied)
- 3 Sediment trap
- 4 Gas connection with isolating valve

Length of pipe in feet	Gas pipe delivery rate in cubic feet of gas per hour ¹⁾				
	1"	1¼"	1½"	2"	2½"
10	520	1060	1600	3050	4800
20	350	730	1100	2100	3300
30	285	590	890	1650	2700
40	245	500	760	1450	2300
50	215	440	670	1270	2000
75	175	360	545	1020	1650
100	160	305	480	870	1400
150	120	250	380	710	1130

Tab. 14 Gas pipe delivery rate

1) Maximum gas pipe delivery rate in cu ft/hr based on a gas specific gravity of 0.60 and a gas pressure of 0.5 psi or less and a pressure drop equivalent to a water column of 0.3 inches.

Iron pipe nominal diameter (in inches)	Equivalent lengths for pipe fittings in feet			
	Pipe fitting type			
	90° elbow	T-piece	Shutoff valve	Gas cock
	Equivalent lengths in feet			
1	3	5	0.6	1.60
1¼	4	6	0.8	2.15
1½	5	7	1.0	2.50
2	7	10	1.3	3.00
2½	8	12	1.6	3.50

Tab. 15 Equivalent lengths for pipe fittings

Disconnect the boiler and its gas isolating valve from the gas supply pipe system if that system is subjected to pressure tests in which the testing pressure exceeds ½ psi.

If the gas supply piping system is subjected to pressure tests in which the testing pressure is ½ psi or less, it is sufficient to isolate the boiler from the gas supply piping system by closing the relevant isolating valve.

- Test the boiler and gas supply connections for leaks before commissioning.

Use only sealant that is resistant to corrosion by NG for the pipe connections. The sealant must be applied sparingly to the external thread of the pipe connections.

6.6 Pipe Sizing

For piping details, see Section 6.1

6.6.1 Three Boiler recommended Near Boiler Piping Size

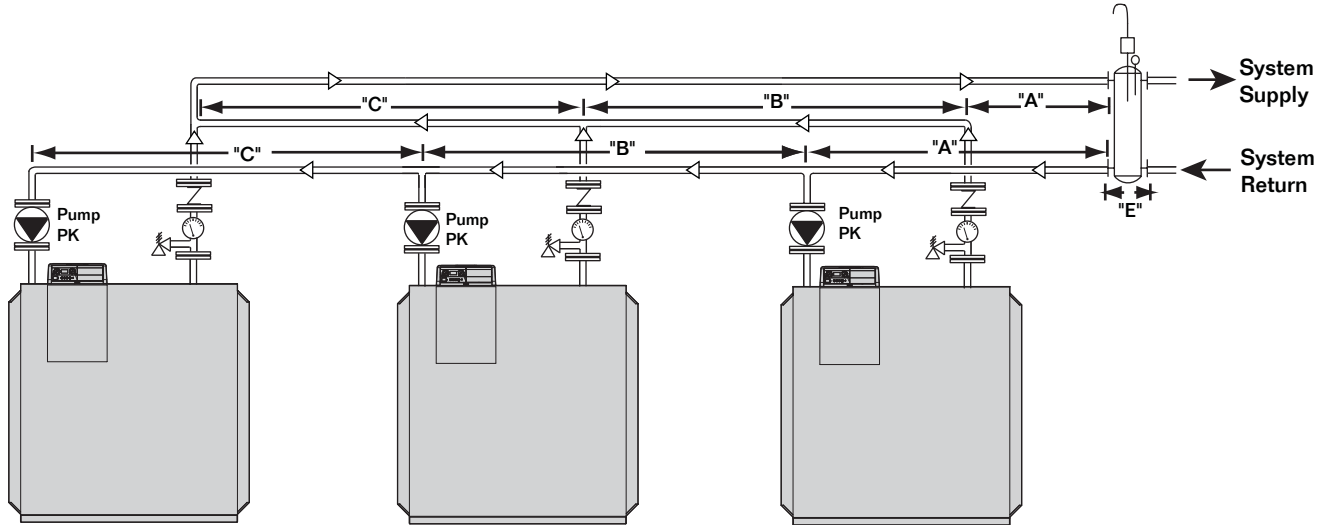

Three GB312 System (18°F Delta T) Recommended Near Boiler Piping Size						Table 16
Models	GB312/90	GB312/120	GB312/160	GB312/200	GB312/240	GB312/280
Pipe A	2½"	3"	4"	4"	4"	4"
Pipe B	2"	2½"	3"	3"	4"	4"
Pipe C	1½"	2"	2½"	2½"	2½"	3"
Header E	2½"	3"	4"	4"	4"	4"

Three GB312 System (36°F Delta T) Recommended Near Boiler Piping Size						Table 17
Models	GB312/90	GB312/120	GB312/160	GB312/200	GB312/240	GB312/280
Pipe A	2"	2½"	2½"	3"	3"	4"
Pipe B	1½"	2"	2"	2½"	2½"	3"
Pipe C	1¼"	1½"	1½"	2"	2"	2½"
Header E	2"	2½"	2½"	3"	3"	4"

See Sections 10.1 and 10.2, Tables 17 to 20 for Boiler pump (PK) and LLHeader (Hydro-Separator) selections.

6.6.2 Four Boiler recommended Near Boiler Piping Size

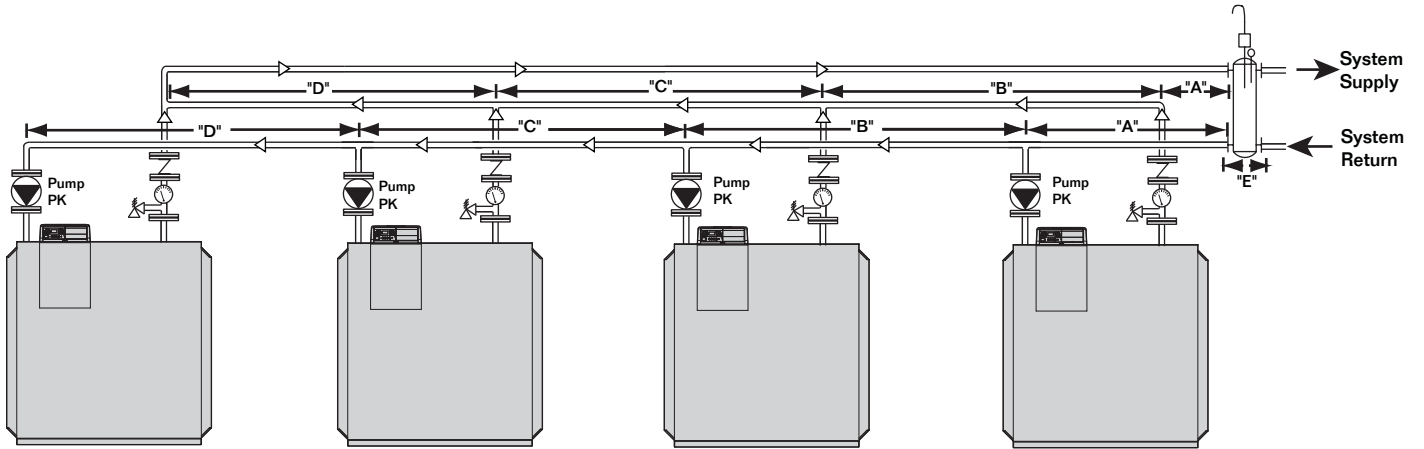

Four GB312 System (18°F Delta T) Recommended Near Boiler Piping Size						Table 18
Models	GB312/90	GB312/120	GB312/160	GB312/200	GB312/240	GB312/280
Pipe A	3"	4"	4"	4"	5"	6"
Pipe B	2½"	3"	4"	4"	4"	4"
Pipe C	2"	2½"	3"	3"	4"	4"
Pipe D	1½"	2"	2½"	2½"	3"	3"
Header E	3"	4"	4"	4"	5"	6"

Four GB312 System (36°F Delta T) Recommended Near Boiler Piping Size						Table 19
Models	GB312/90	GB312/120	GB312/160	GB312/200	GB312/240	GB312/280
Pipe A	2½"	3"	3"	4"	4"	4"
Pipe B	2"	2½"	2½"	3"	3"	4"
Pipe C	2"	2"	2½"	2½"	2½"	3"
Pipe D	1½"	1½"	2"	2"	2"	2½"
Header E	2½"	3"	3"	4"	4"	4"

See Sections 10.1 and 10.2, Tables 17 to 20 for Boiler pump (PK) and LLHeader (Hydro-Separator) selections.

7 CSD-1 Kit

- Call Bosch Thermotechnology Corp. to order the pair of gas line pressure switches (1H.P. + 1L.P.)
- The part number to order is 7747019985 for both
- Low pressure switch part number is C6097A1061
- High pressure switch part number is DG15CTG15W
- Low water cut-out (LWCO) and Hi Limit manual reset switches to be ordered seperately.
- Part numbers are the following:
LWCO - 550
Hi Limit - L4006E1109

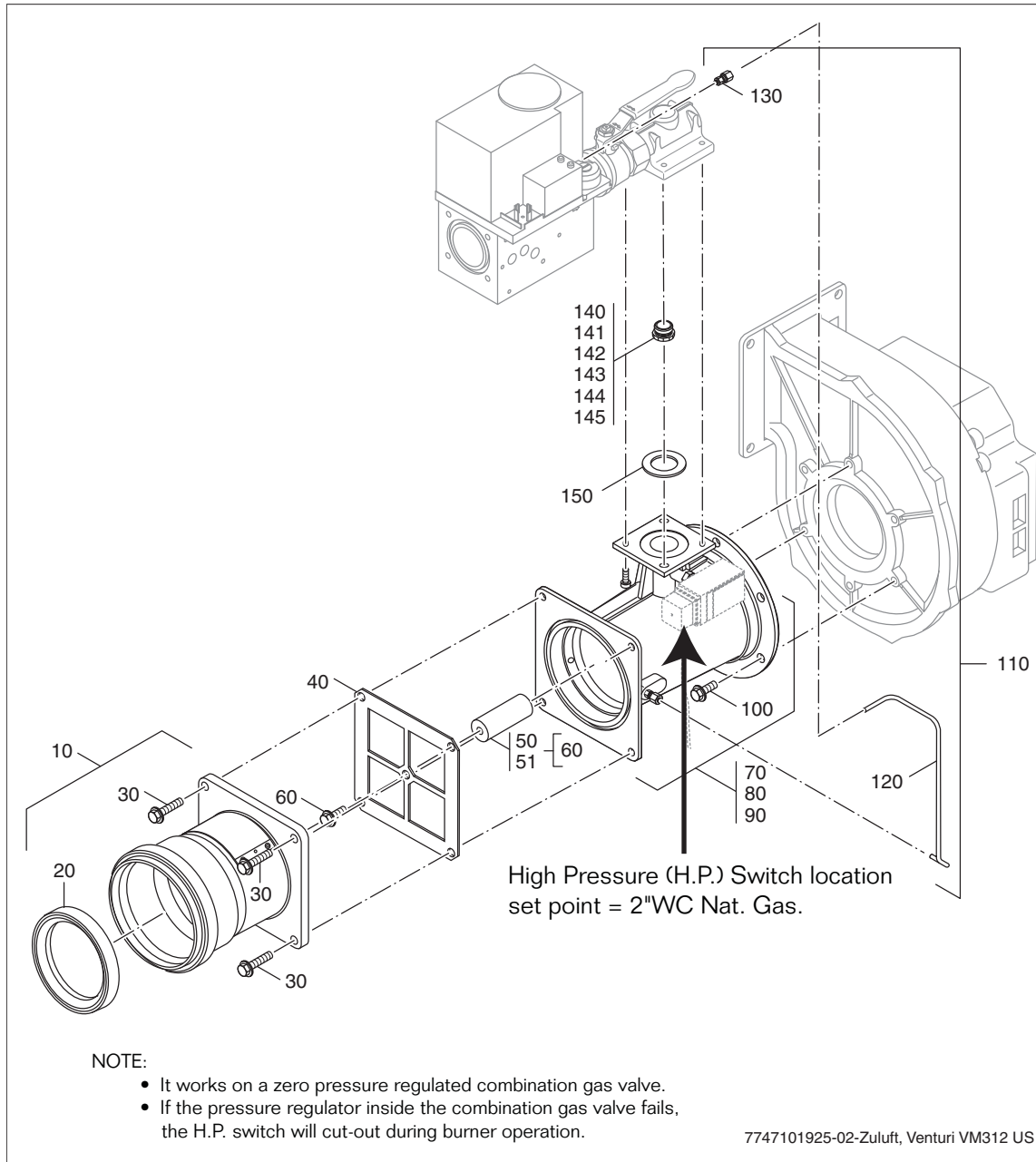

Fig. 21 Air inlet, venturi GB312 US

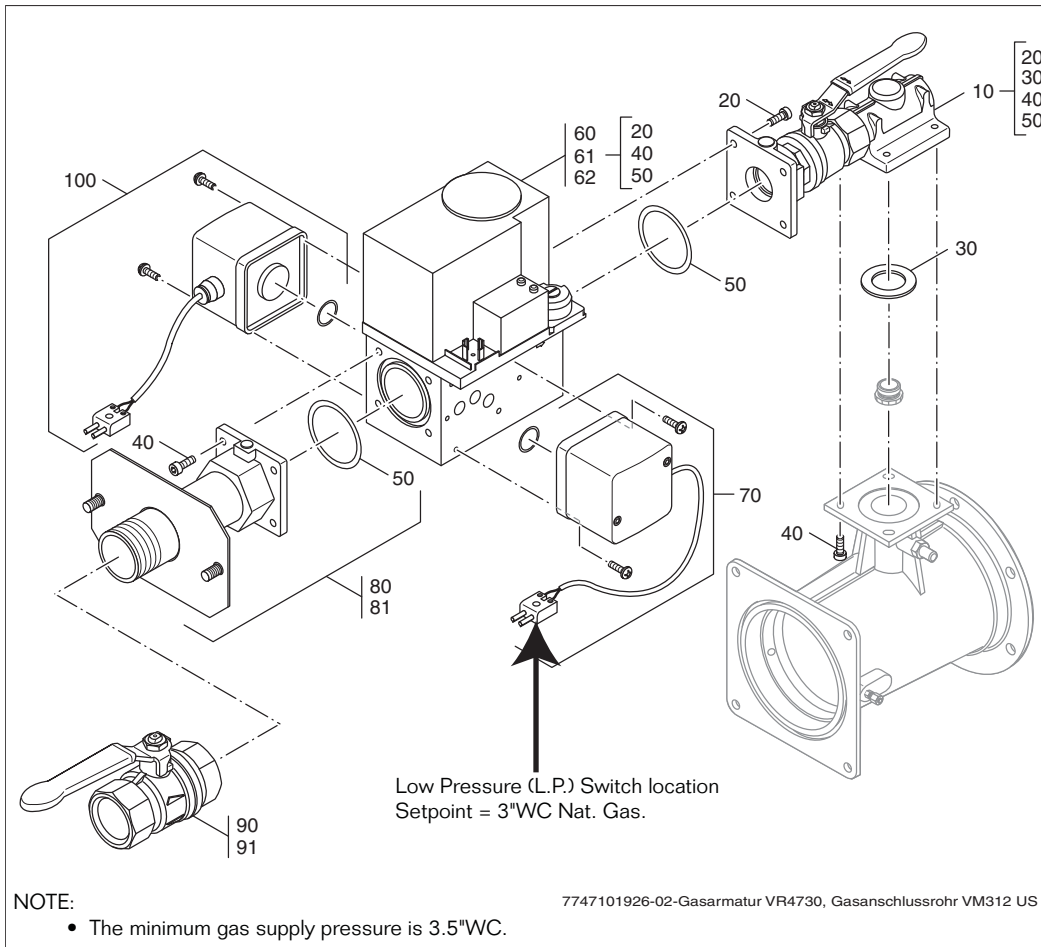

Fig. 22 Gas valve VR4730, gas connecting pipe GB312 US

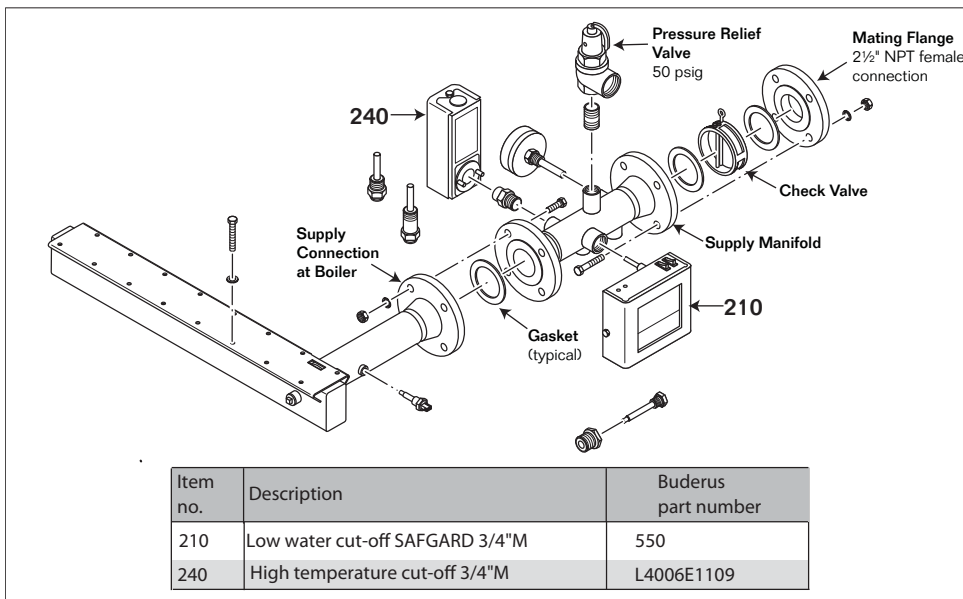
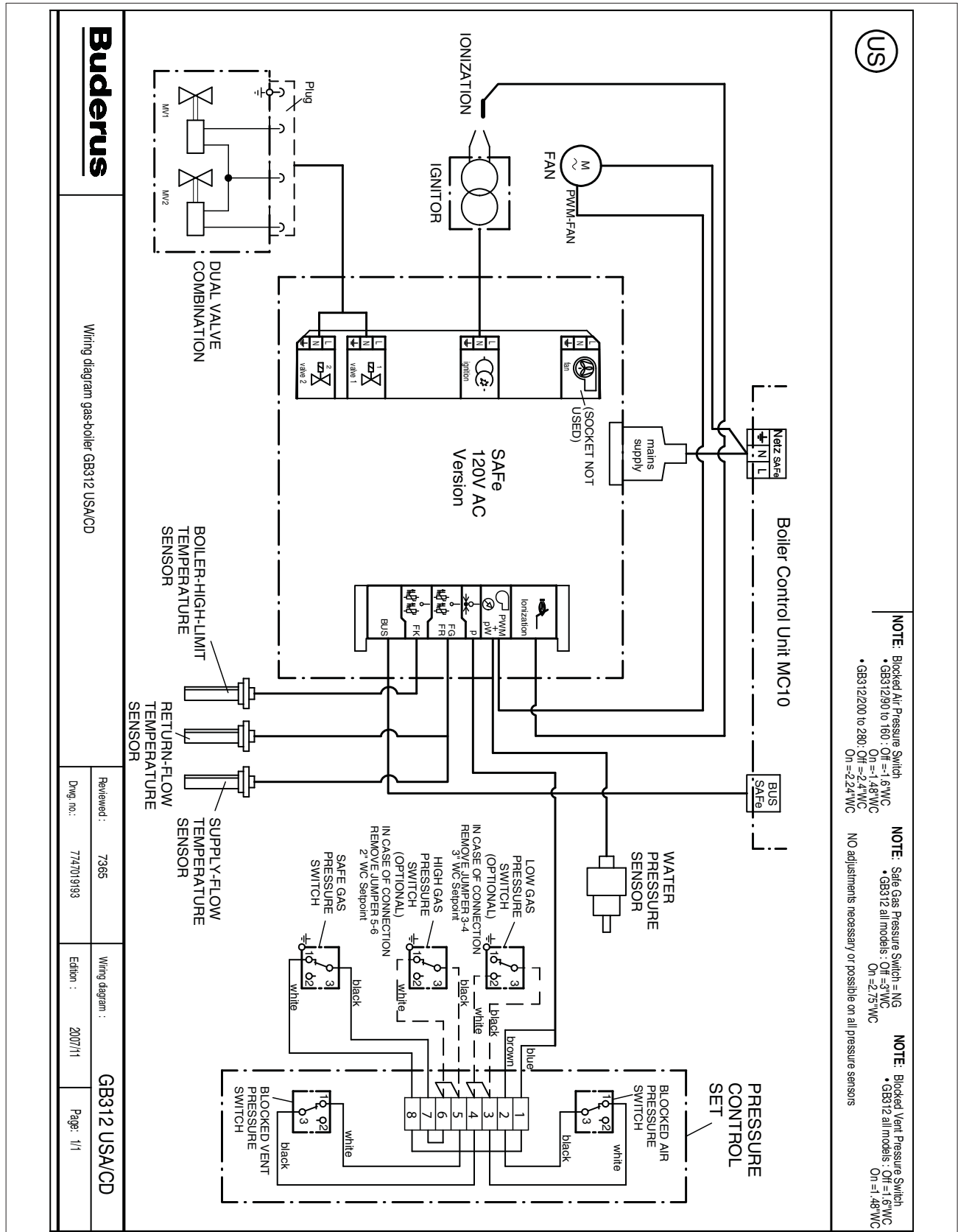

Fig. 23 Boiler Supply Manifold and Controls.

7.1 Operating Addendum for the GB312 in High Temperature Applications

It is extremely important that the default post purge for the boiler pump be left alone. The default setting is 5 minutes post purge. This setting may be accessed in the service level of the BC10 controller. The setting may be increased if needed but may NOT be decreased. This will ensure that the boiler does not exceed the safety limit regardless of system flow rates when using a ASME CSD1 high temperature cut off at the boiler supply.

8 Boiler internal wiring diagram



Buderus

Wiring diagram gas-boiler GB312 USA/CD

Revised: 7365
 Dwg. no.: 77470/9193

Wiring diagram:
 Edition: 2007/11

GB312 USA/CD

Page: 1/1

10 Sequence of operations

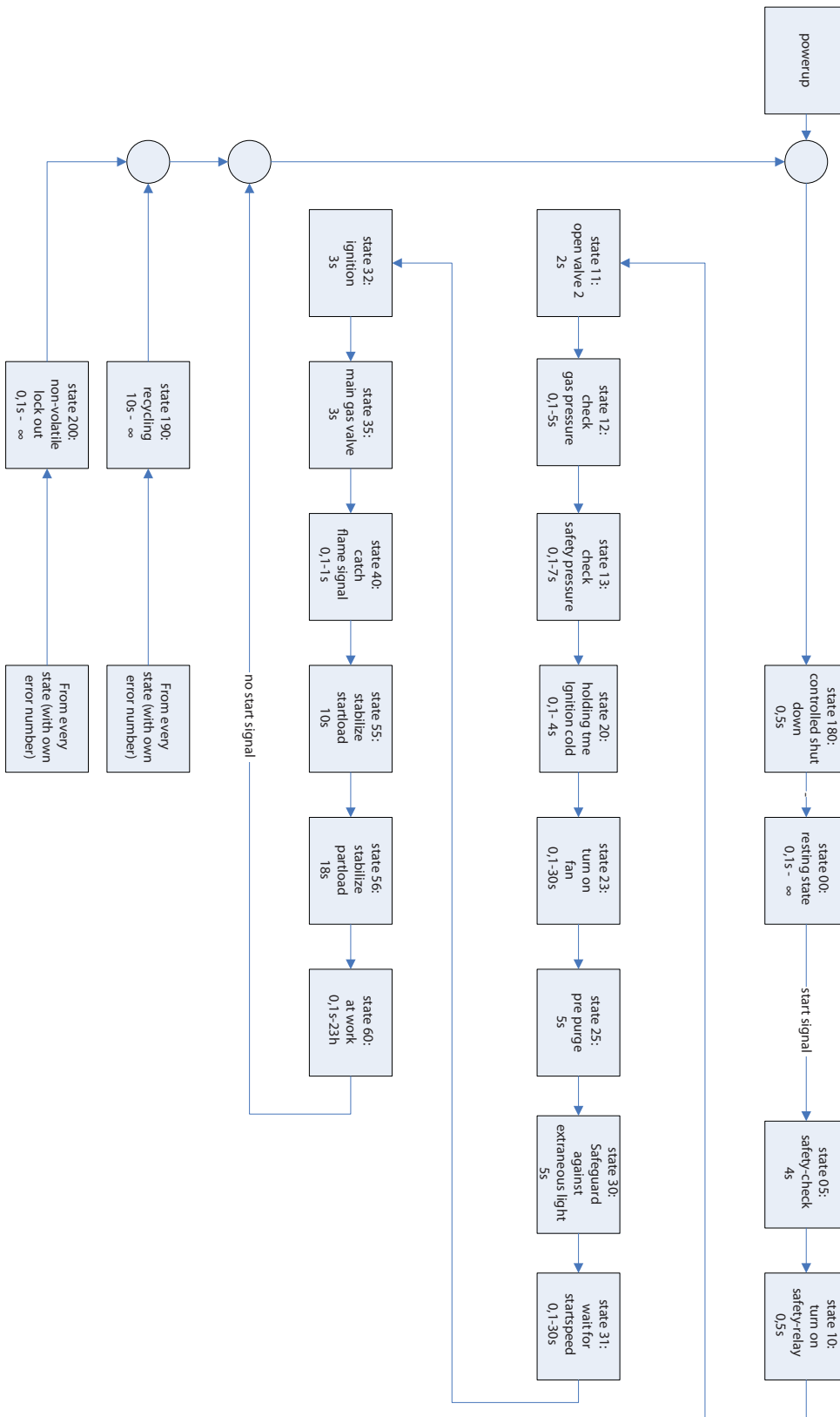

11 High Altitude Adjustment

11.1 General



DANGER:

- If installation, adjustment, modification, operation or maintenance of the heating system is carried out by an unqualified person, this may result in danger to life and limb or property damage. These instructions must be followed precisely. Contact a qualified service company, service provider or the gas company if support or additional information is required.

11.1.1 Input Rates

Models	Input rate (Mbtu/hr)
GB312-90	328
GB312-120	441
GB312-160	588
GB312-200	733
GB312-240	881
GB312-280	1029

11.3 CO₂ adjustment of the burner / adjustment of the gas valve

The CO₂ level of the burner has to be adjusted by using a CO₂ / CO-meter accordingly to the following instruction steps (see CO₂ values in Table 21 below).

For boiler commissioning procedures, please see 'Installation and Maintenance Manual' chapter 7 (page 41). The CO level in the flue gas has to be less than 100ppm (air free). If a setting of 9.1 Vol.% CO₂ and a CO level under 100ppm (af) is not possible due to the used natural gas, a lower CO₂ level with CO emissions under 100ppm (af) has to be adjusted.

Models		CO ₂ (Vol. %)	CO (ppm (af))
GB312-90	min-/max- load	9.1 / 9.1	<100
GB312-120	min-/max- load	9.1 / 9.1	<100
GB312-160	min-/max- load	9.1 / 9.1	<100
GB312-200	min-/max- load	9.1 / 9.1	<100
GB312-240	min-/max- load	9.1 / 9.1	<100
GB312-280	min-/max- load	9.1 / 9.1	<100

11.2 Adjustments



The high altitude adjustment of the GB312 boiler series consists of two adjustment steps.

1. CO₂ adjustment of the burner by changing the setting of the automatic gas valve.
2. Correction of the fan speed curve of the burner.

11.3.1 Set BC10 control to "flue gas test" operation

The  button is used by the heating engineer for the flue gas test.

The control system runs the heating at a raised flow temperature for 30 minutes. During the flue gas test, the decimal point on the status display lights up.

- Press and hold the  button until the decimal point on the status display lights up (at least 2 seconds, to cancel the flue gas test the  button has to be pressed again).

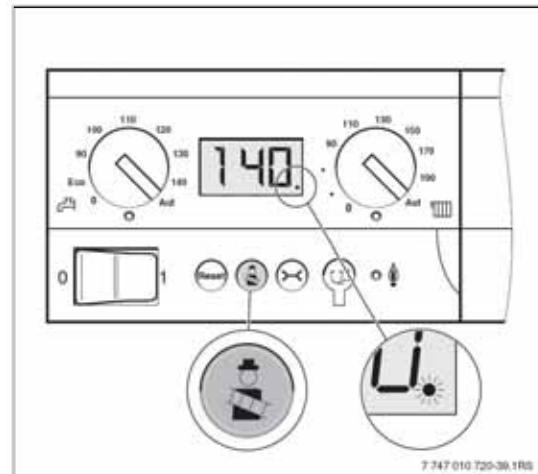









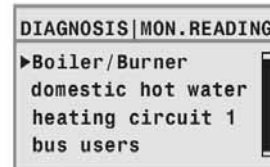
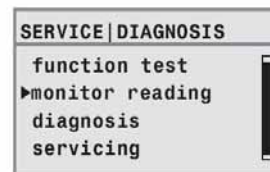
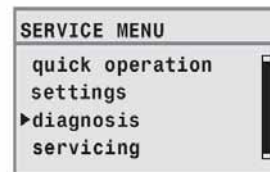

Fig. 24 Starting the flue gas test

11.3.2 Opening the Service menu and viewing monitor data on the RC35

- Simultaneously press the  +  +  buttons to open the **SERVICE MENU**.
- Turn the rotary selector  counter-clockwise to select **Diagnosis** (indicated by >).
- Press the  button to open the **SERVICE/DIAGNOSIS** menu.
- Turn the rotary selector  counter-clockwise to select **Monitor reading** (indicated by >).
- Press the  button to open the **DIAGNOSIS/MONITOR READING** menu.
- Turn the rotary selector  counter-clockwise to select **Boiler/Burner** (indicated by >).
- Press the  button to open the **BOILER/BURNER** menu.
The monitor readings are displayed as a list, i.e. turning the selector scrolls down to more readings.



These menus enable you to read off the current boiler output (set / actual).

11.3.3 Adjusting and checking CO₂ level at maximum output

- Read off output on RC35.
- Wait until output reaches at least 70%.
- Insert the sensor through a testing hole in the flue pipe into the center of the gas flow.
- Adjust the level to 9.1% CO₂ using the high-output adjusting screw (Fig. 25, item 1). **Do not exceed CO limit given in Table 21.**
 - Turning the screw clockwise reduces the CO₂ level.
 - Turning the screw counter-clockwise increases the CO₂ level.

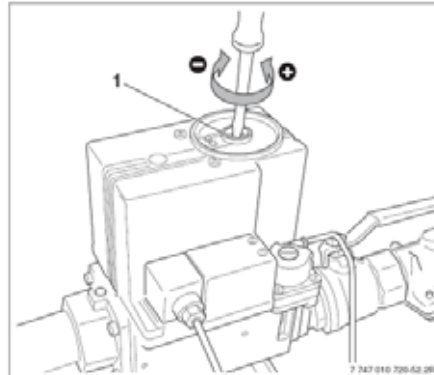





Fig. 25 Setting the CO₂ at maximum output
1 High output adjusting screw

11.3.4 Adjusting and checking CO₂ level at minimum output

- Set to 30%.
To do so, press and hold the  button until the decimal point on the status display lights up (at least 2 seconds). This turns on the flue gas test.
- Simultaneously press and hold the  and  buttons for approx. 5 seconds.
At the factory setting, the display shows "L _ _".
- Press the  button to reduce the boiler output to a percentage of maximum until the display shows "L30".
- Read off output on RC35.
- Wait until the output drops to 30%.
- Adjust the level to 9.1% CO₂ using the low-output adjusting screw (Fig. 25, item 1). **Do not exceed CO limit given in Table 21.**
 - Turning the screw clockwise increases the CO₂ level.
 - Turning the screw counter-clockwise reduces the CO₂ level.

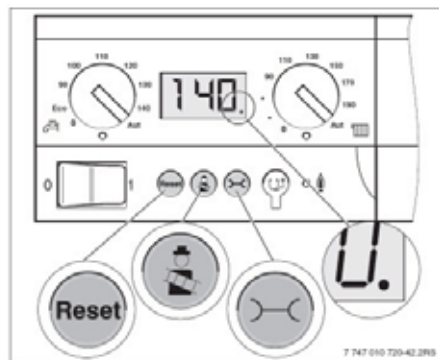

Fig. 26 Setting minimum output

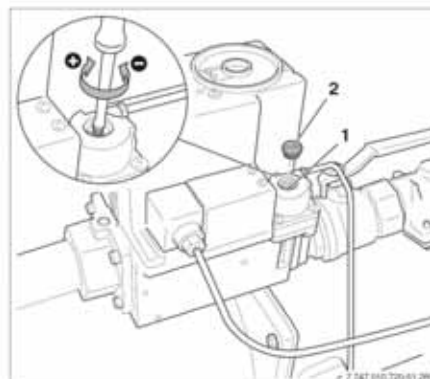



Fig. 27 Setting the CO₂ at minimum output
1 Low-output adjusting screw gas valve Honeywell V4730C
2 Cap screw

11.3.5 Check and monitoring CO₂ level at maximum output

- Press the  button to increase the boiler output to a higher percentage.
- Read off output on RC35.
- Wait until output reaches at least 70%.
- Check CO₂ content again.

11.3.6 Recording measured values

- Take the following readings at a testing point on the flue pipe and record them in the commissioning log → (Installation and Maintenance Manual: Section 7.20, page 54):
 - Flue pressure
 - Flue gas temperature t_A
 - flame ionization current
 - Carbon dioxide content (CO₂) or oxygen content (O₂)
 - Carbon monoxide content (CO)
- Cancel the flue gas test and press the  button again.

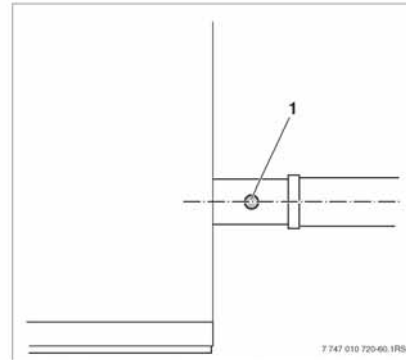







Fig. 28 Recording the measured values
1 Recommended location for testing point on flue pipe

11.4 Settings for speed of burner fan

The fan speed curve of the burner has to be adjusted by using the programming mode of the BC10 control and the parameter settings from Table 23 of this instruction.

Setting of fan speed parameter in programming mode

-  +  Press the “Chimney sweep” and “Status display” buttons at the same time for 5 seconds to enter programming mode.
-  Press the “Status display” button 4 times to go to the maximum fan speed parameter (BC10 display will show: “2.0”).
-  Press the “Reset” button to reduce the value of the parameter (-).
-  Press the “Chimney sweep” button to increase the value of the parameter (+).

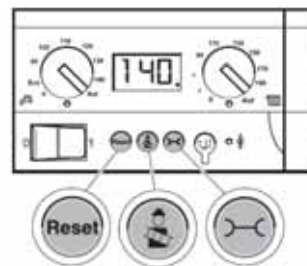

Programming mode is terminated if no button is pressed for 5 minutes.



This parameter can be used to correct the input load of the burner. It can be used for adjusting the fan speed for high altitude operation (see Table 22 below).

BC10 parameter range for fan adjustment of GB312 boilers		Table 22
Parameter	Input range	Factory setting for sea level operation
Burner input load correction: 2	0 to +9 [- settings lower than 0 will be ignored by the control]	2.0





























One parameter increment correlates to an increase of approx. 0.6% burner input load.

BC10 parameter settings for adjustment of fan speed						Table 23
GB312 boiler size	0 - 2000ft (0 - 610m)	2001 - 4500ft (611 - 1372m)	4501 - 7000ft (1373 - 2134m)	7001 - 9500ft (2135 - 2896m)	9501 - 12000ft (2897 - 3666m)	
90 120 160	2.0	2.1	2.2	2.3	2.4	
200 240 280	2.0	2.2	2.4	2.6	2.8	

12 Installation examples

12.1 Legend

Legend

Valves	Miscellaneous	Line Types
 Shut Off Valve	 Air Separator	 Low Temperature Return
 Flow Check Valve	 Sensor	 High Temperature Return
 Two Way Valve	 Circulator	 Supply
 Pressure Bypass Valve	 Temperature Gauge	 Mixed Temperature Supply
 Drain Valve	 Drain	 Domestic Hot Water Supply (DHW)
 Pressure Relief Valve	 Temperature Gauge/ Shut Off Valve	 Domestic Hot Water Recirculation (DHW R)
 Three Way Valve	 Outdoor Sensor	 City/Well Water Supply
 Low Loss Header	 Expansion Tank	 Control Inputs
	 Expansion Tank	 Control Outputs
	 Expansion Tank	 Control Communication
		 Local EMS Control Outputs

12.2.3 Single boiler with AM10, DHW and system circulator

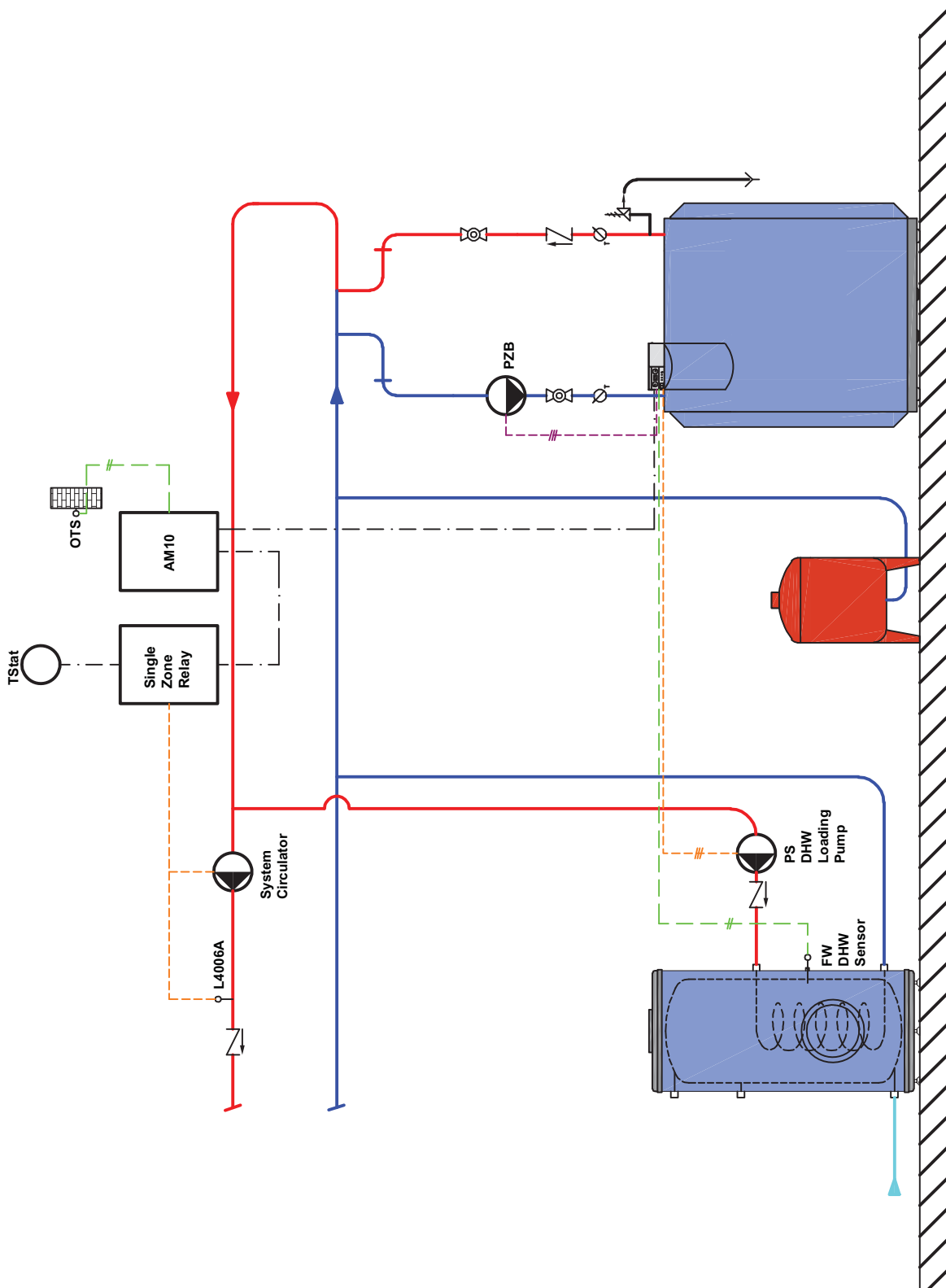

See page 46 for wiring diagram

12.2.4 Wiring diagram for single boiler with AM10, DHW and system circulator

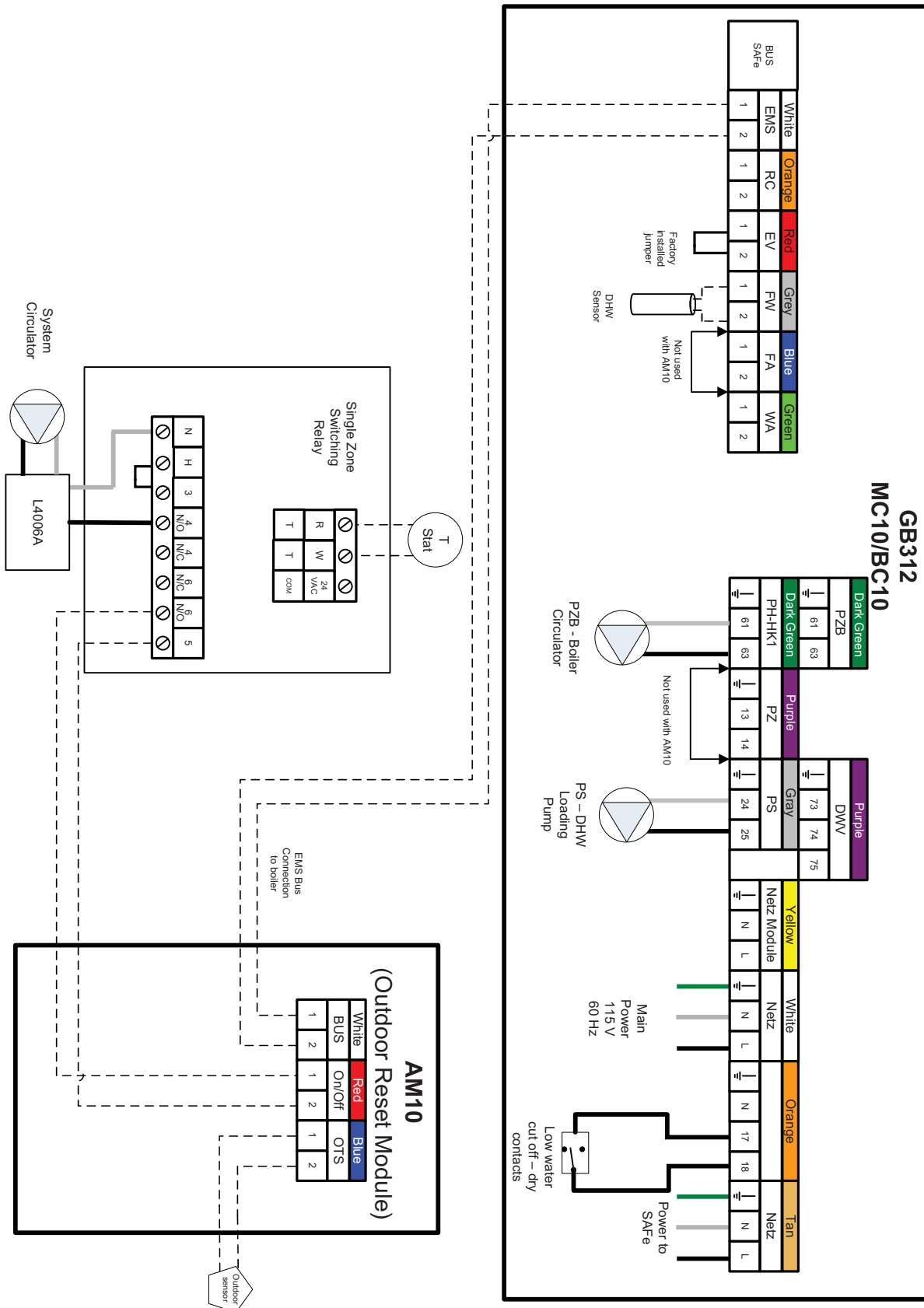

See page 45 for piping diagram

Buderus

12.2.5 Single boiler with AM10, DHW and multiple heat zones

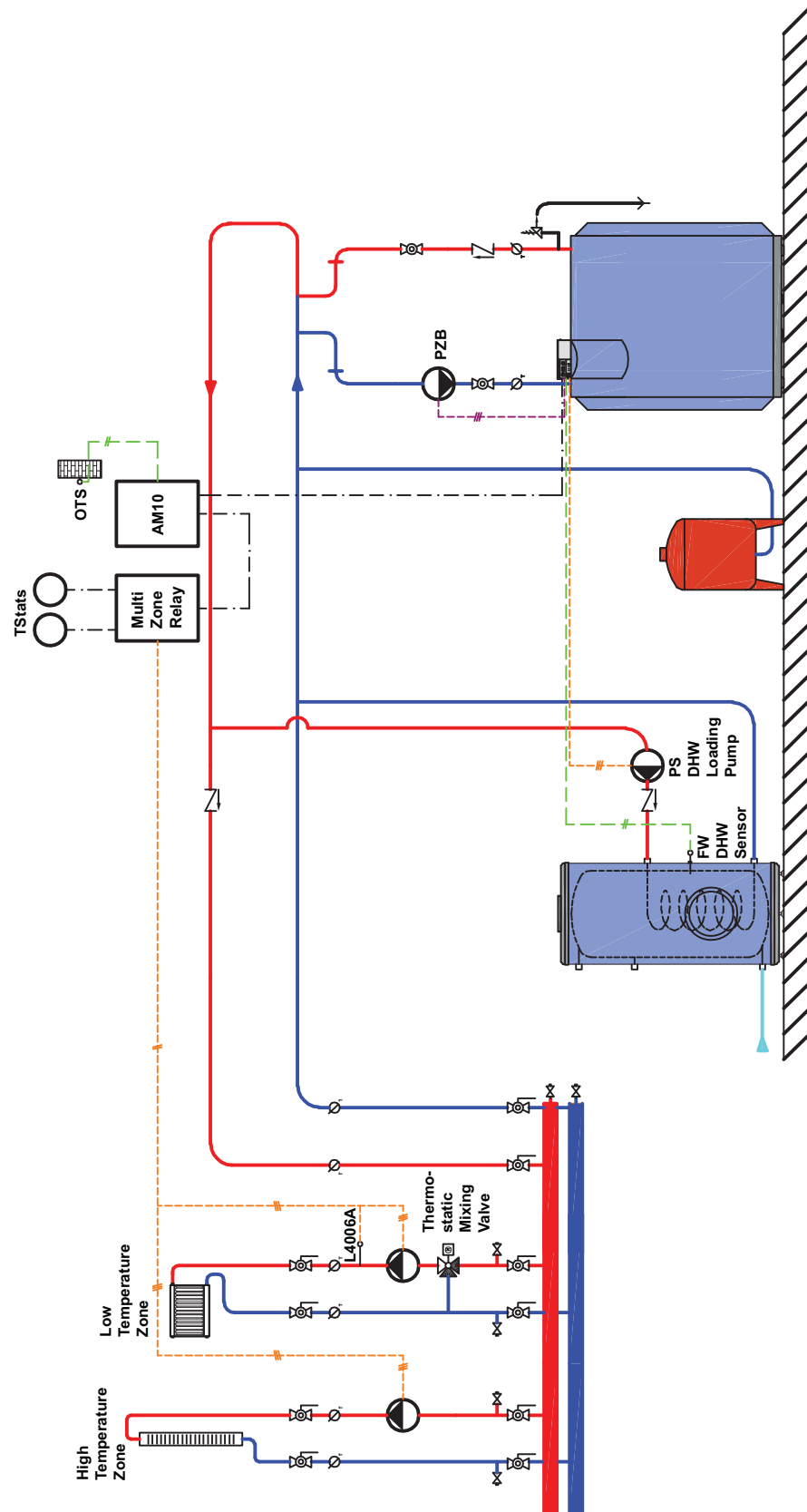

See page 48 for wiring diagram

12.2.6 Wiring diagram for single boiler with AM10, DHW and multiple heat zones

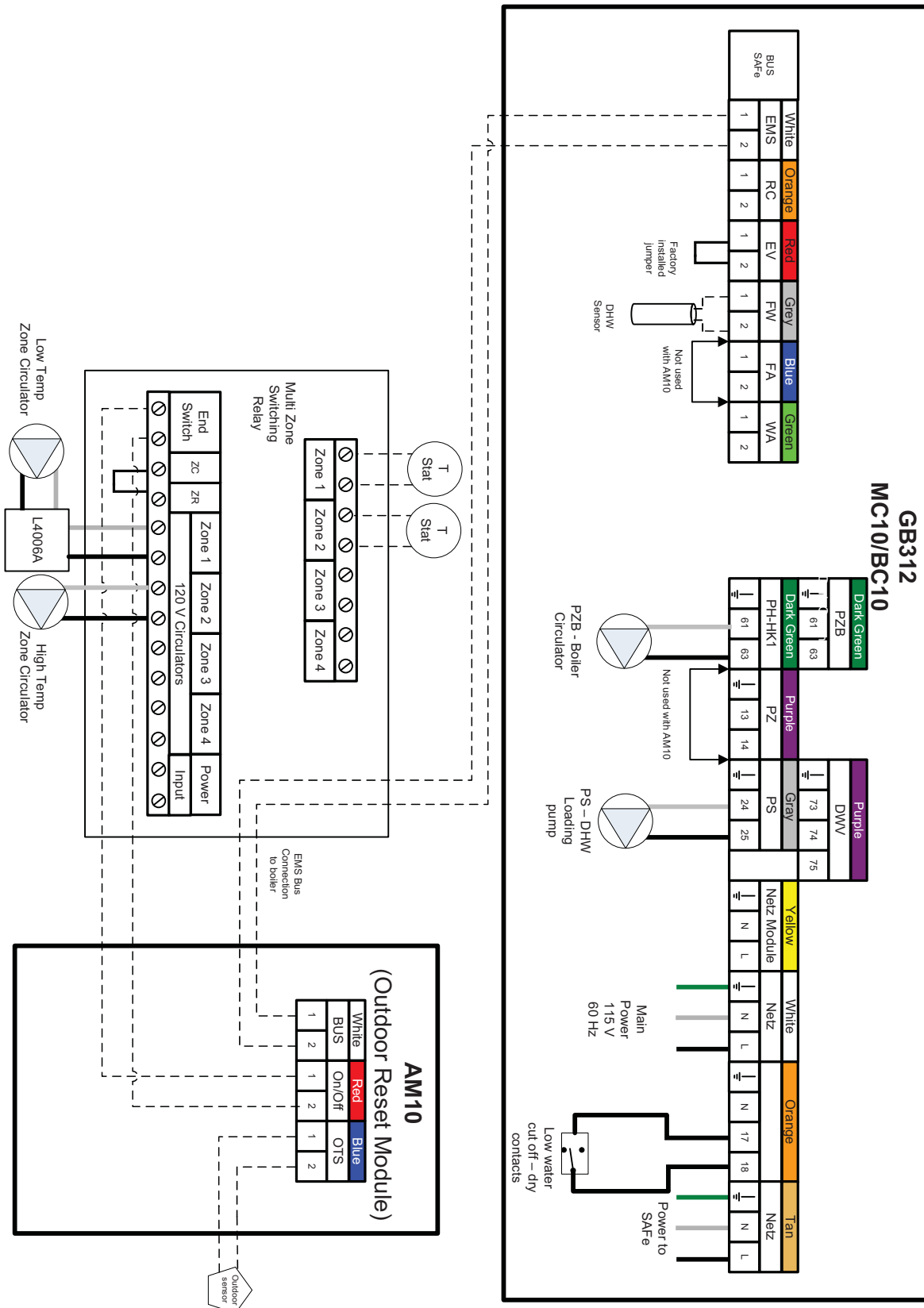

See page 47 for piping diagram

12.3 Multiple boiler systems

12.3.1 Two boiler cascade with low loss header, CM10, DHW and multiple heat zones

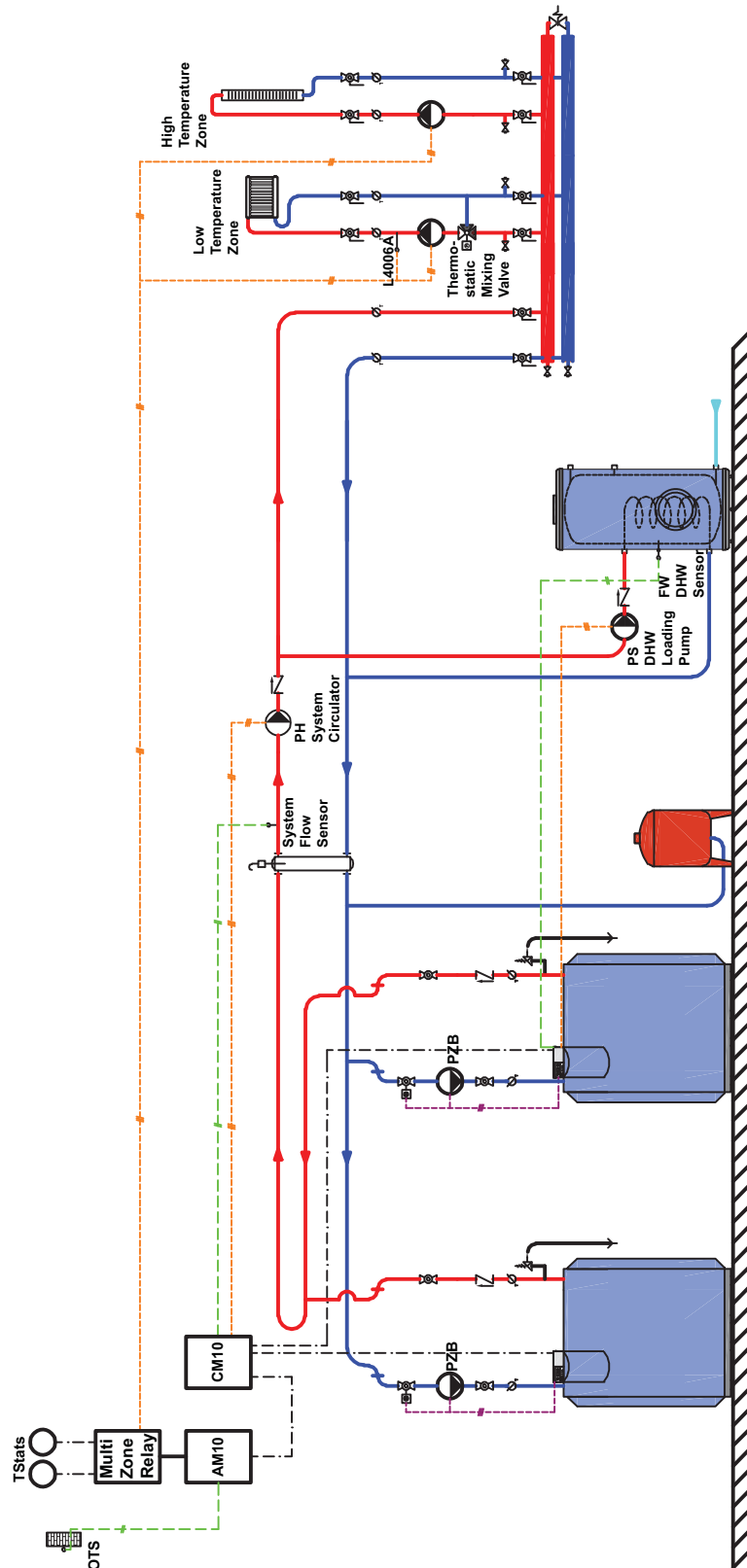

See pages 50 and 51 for wiring diagram

12.3.2 Wiring diagrams for two boiler cascade with low loss header, CM10, DHW and multiple heat zones

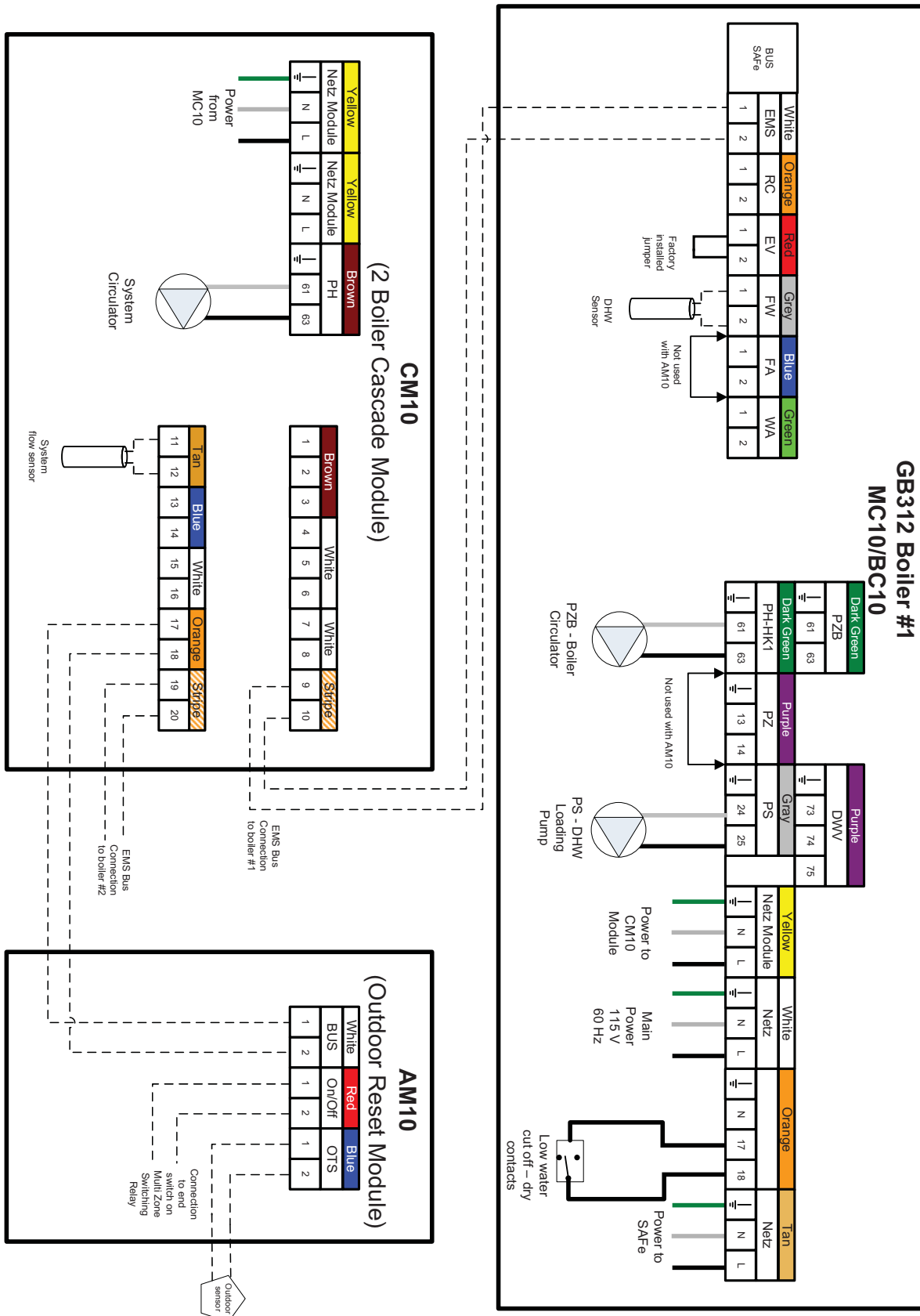

See page 49 for piping diagram

GB312 Boiler #2 MC10/BC10

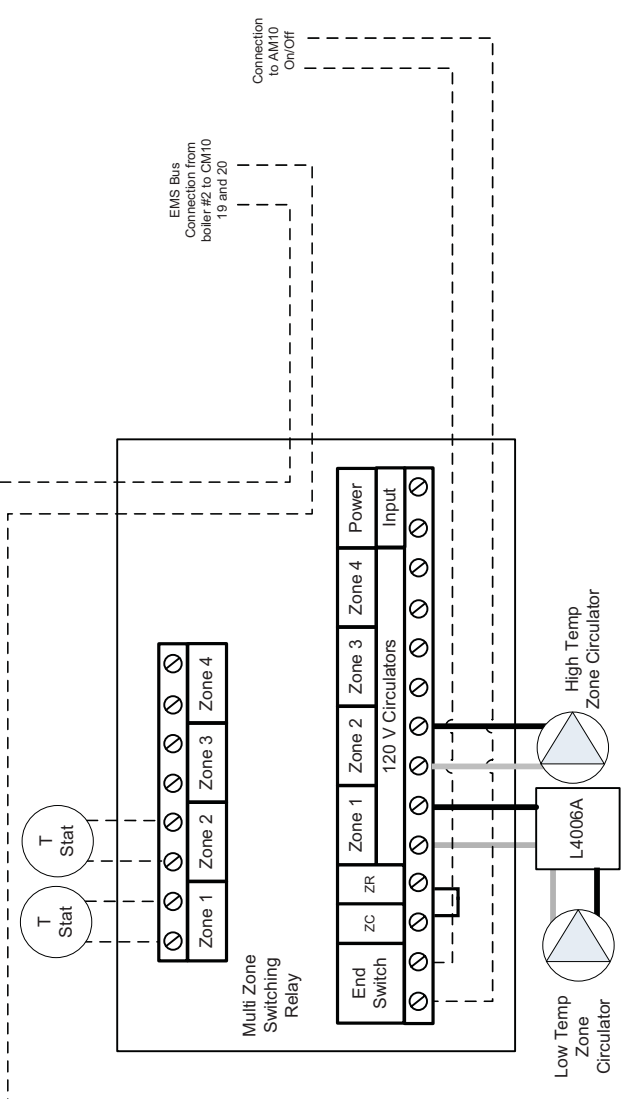
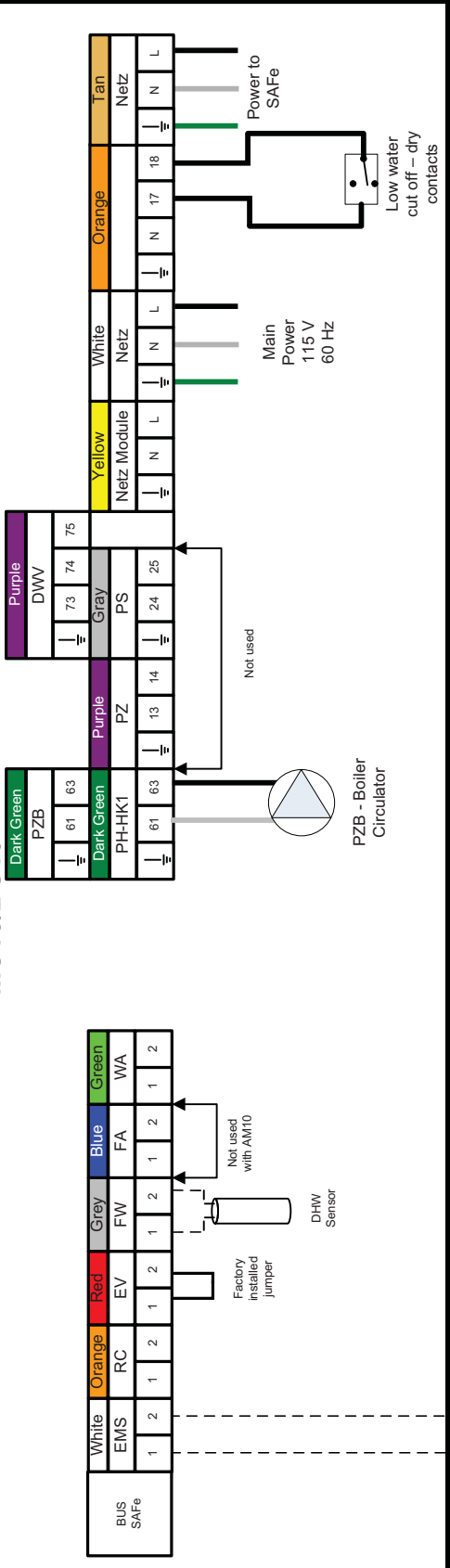

See page 49 for piping diagram

12.3.3 Two boiler installation with Logamatic 4323 and FM456

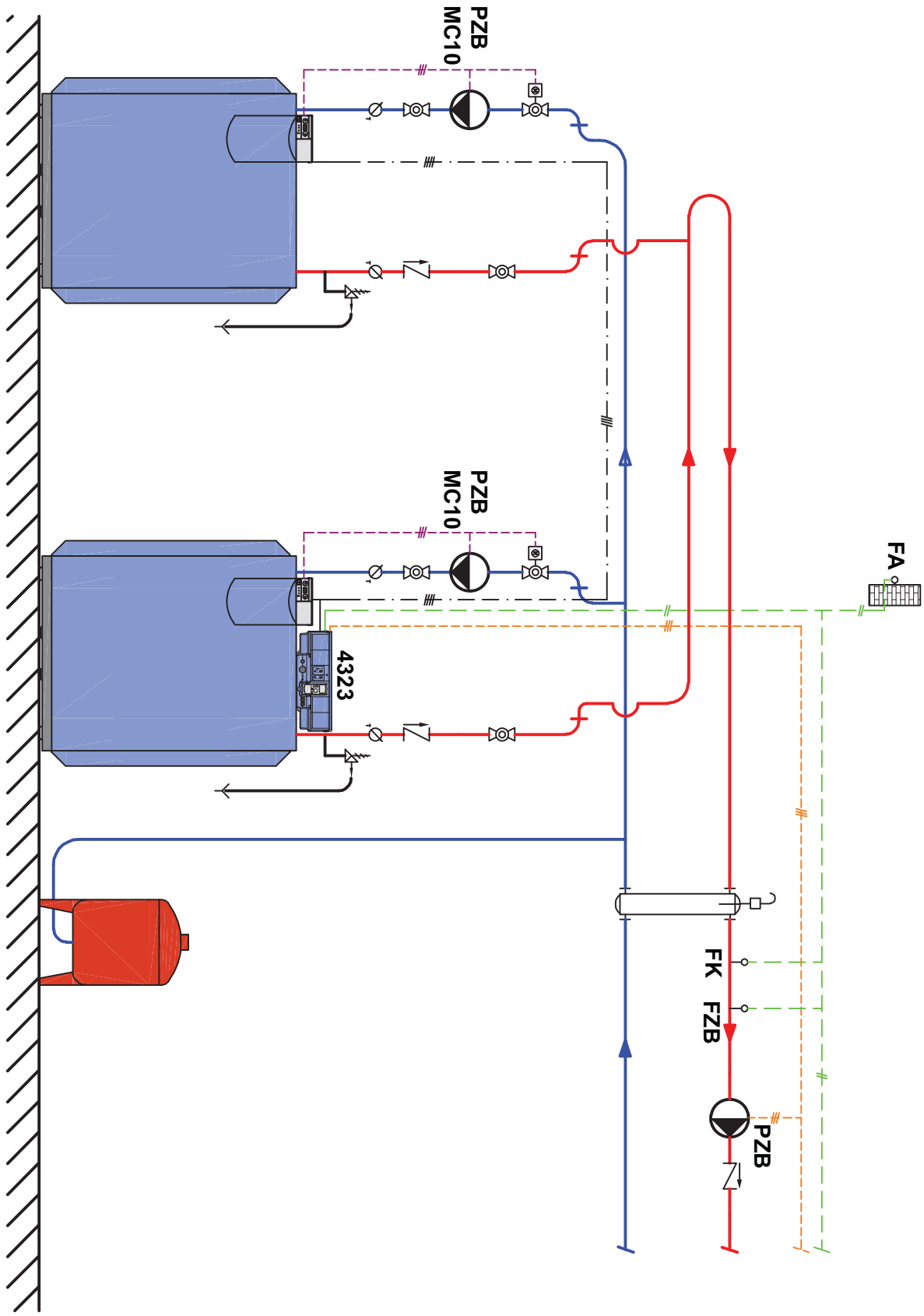

12.3.5 Four boiler installation with Logamatic 4323 and FM457

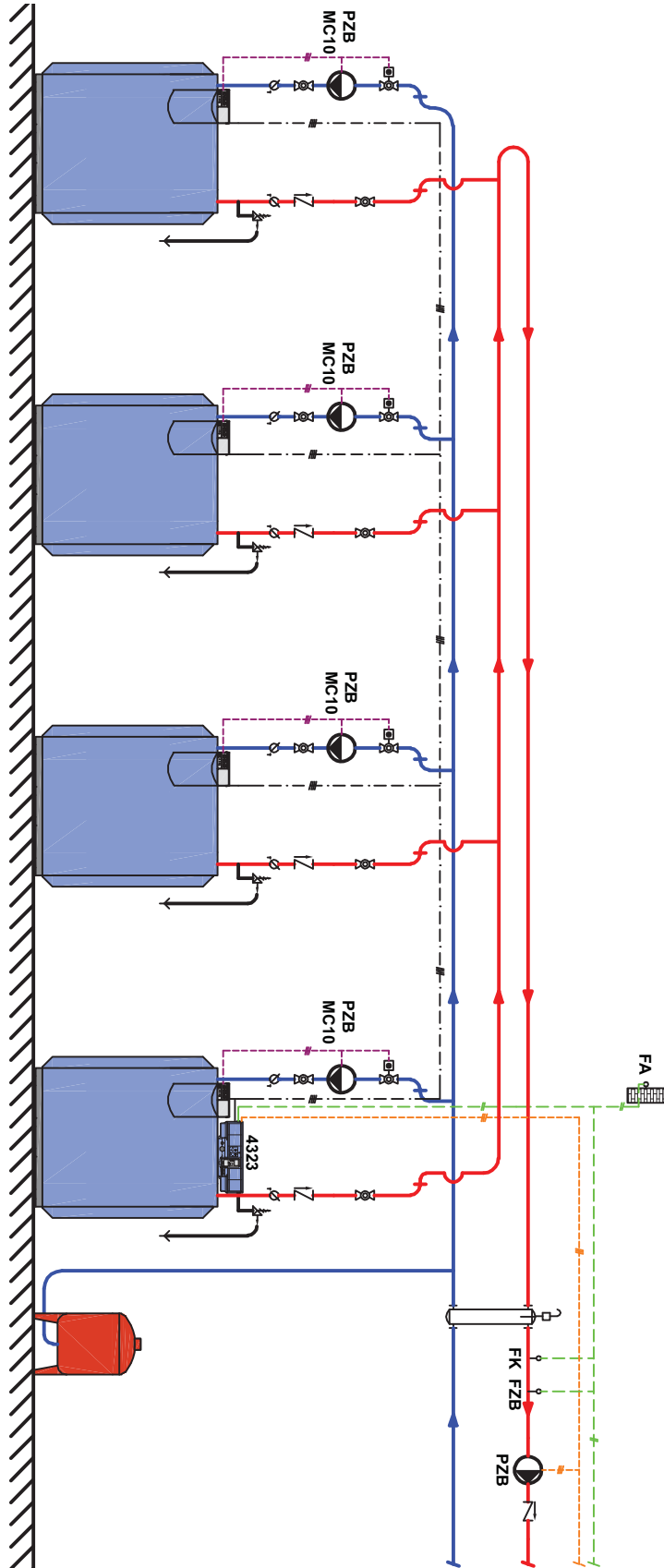

See page 55 for wiring diagram

12.3.6 Wiring diagrams for Four boiler installation with Logamatic 4323 and FM457

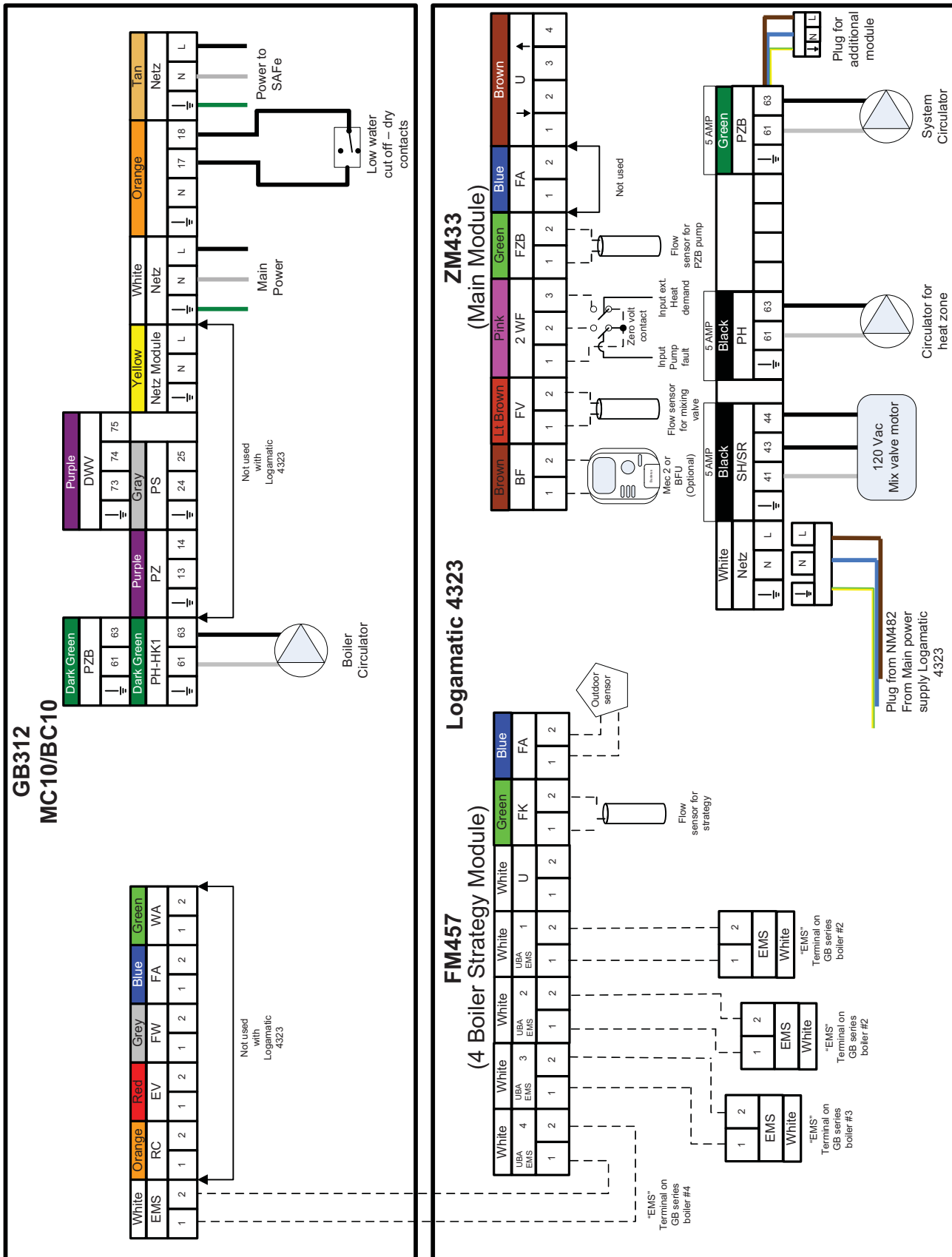

See page 54 for piping diagram

12.3.7 GB312 Multiple Boiler Primary and Secondary Piping Diagram Without Low Loss Header

1. Piping shall be equal and in reverse return.
2. Pipe sizing based on two boiler with 18°F or 36°F Delta T.

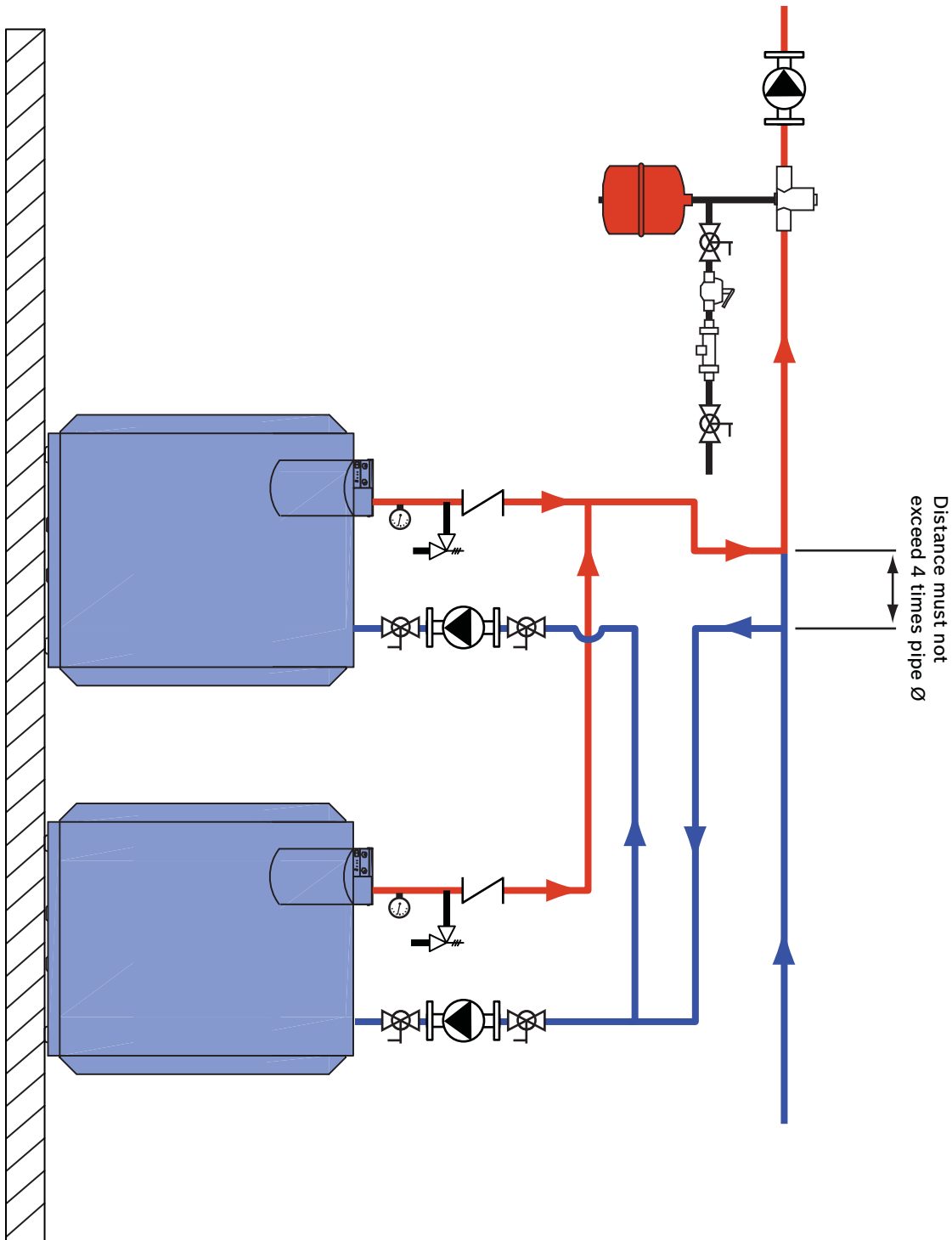

13 Pump & low loss header (hydro-seperator) selection

13.1 Pump selection based on delta T.

dT = 10°C (18°F) Single Boiler Installation							Table 24		
BOILER DATA				BOILER PUMP SELECTION			HYDRO-SEPERATOR		
Models	Flowrate (gal/min)	Boiler pressure drop (PSI)	Check valve pressure drop (PSI)	Grundfos pump selection	B & G pump selection	Taco pump selection	Caleffi Hydro-seperator selection	Sinus Hydro-seperator selection	Nominal Size
GB312-90	30	3.4	0.3	UP26-99	607S	1400-20	548082A	7-26-200	3" Flanged
GB312-120	45	4.6	0.6	UPS40-40	607S	1400-65	548082A	7-26-200	3" Flanged
GB312-160	60	4.5	0.6	UPS40-80/4	608S	1400-70	548082A	7-26-200	3" Flanged
GB312-200	75	5.2	0.9	UPS50-80/4	609S	1400-70	548102A	7-26-250	4" Flanged
GB312-240	90	5.2	1.2	UPS50-80/4	611S	1632	548102A	7-26-250	4" Flanged
GB312-280	106	5.5	1.7	UPS80-80	612S	1632	548102A	7-26-250	4" Flanged

dT = 20°C (36°F) Single Boiler Installation							Table 25		
BOILER DATA				BOILER PUMP SELECTION			HYDRO-SEPERATOR		
Models	Flowrate (gal/min)	Boiler pressure drop (PSI)	Check valve pressure drop (PSI)	Grundfos pump selection	B & G pump selection	Taco pump selection	Caleffi Hydro-seperator selection	Sinus Hydro-seperator selection	Nominal Size
GB312-90	15	0.9	0.1	UP15-42	607S	1400-10	548052A	7-25-120	2" Flanged
GB312-120	23	1.2	0.2	UP26-64	607S	1400-10	548052A	7-25-120	2" Flanged
GB312-160	30	1.2	0.2	UP26-99	607S	1400-20	548082A	7-26-200	2" Flanged
GB312-200	37	1.3	0.2	UPS32-40	607S	1400-20	548082A	7-26-200	3" Flanged
GB312-240	45	1.3	0.3	UPS40-40	607S	1400-40	548082A	7-26-200	3" Flanged
GB312-280	53	1.4	0.4	UPS40-40	608S	1400-45	548082A	7-26-200	3" Flanged

13.2 Low loss header selection per manufacturer

CALEFFI

Multiple boiler applications			Table 26	
Combined Flowrate (gal/min)	Mains pipe size	Caleffi Hydro-seperator selection ASME registered	Caleffi Hydro-seperator selection Non-ASME	Nominal Size
up to 247 gpm	4"	NA548102A	548102A	4" Flanged
up to 300 gpm	5"	NA548120A	not offered	5" Flanged
up to 484 gpm	6"	NA548150A	not offered	6" Flanged
up to 792 gpm	8"	NA548250A	not offered	8" Flanged
up to 1,330 gpm	10"	NA548300A	not offered	10" Flanged
up to 1,850 gpm	12"	NA548300A	not offered	12" Flanged

SINUS

Multiple boiler applications			Table 27	
Combined Flowrate (gal/min)	Mains pipe size	Sinus Hydro-seperator selection	Nominal Size	
up to 115 gpm	4"	7-26-250	4" Flanged	
up to 190 gpm	5"	7-26-300	5" Flanged	
up to 250 gpm	6"	7-26-400	6" Flanged	
up to 375 gpm	8"	7-26-450	8" Flanged	
up to 480 gpm	8"	7-26-500	8" Flanged	
up to 745 gpm	10"	1-51-218	10" Flanged	
up to 1,030 gpm	12"	1-51-220	12" Flanged	
up to 1,320 gpm	14"	1-51-222	14" Flanged	



Bosch Thermotechnology Corporation
50 Wentworth Avenue
Londonderry, NH 03053
Tel.: 603-552-1100
Fax: 603-584-1681
www.buderus.net

Products manufactured by:
Bosch Thermotechnik GmbH
Sophienstrasse 30-32
D-35576 Wetzlar
www.buderus.de

Bosch Thermotechnology Corporation reserves the right to
make changes without notice due to continuing engineering
and technological advances.

BTC 431001102 B | 12.2009

Buderus

Bosch Group