

Instructions for High Altitude Conversion

Logano G334 X gas-fired boiler

This conversion kit and the accompanying instructions are for conversion of G334 X gas-fired boilers for operation at altitudes above 8500 feet.

Required Sealevel Input Rates of 0-8500 feet

G334 X-73 301 MBtu/hr	G334 X-92 387 MBtu/hr	G334 X-116 476 MBtu/hr	G334 X-132 541 MBtu/hr
--------------------------	--------------------------	---------------------------	---------------------------

WARNING!

This conversion kit is intended for use by a qualified service company only as specified by the manufacturer's instructions and the current applicable rules and regulations of the local authorities and the regulations of NFPA54, CAN/CGA B149.1 and 2, Installation Code, must also be observed. If these instructions are not followed exactly, a fire, explosion or release of carbon monoxide may occur with serious property damage or loss of life and serious injury. The heating contractor is liable for correct conversion of the heating system with this conversion kit.



WARNING!

Please use the enclosed instructions for conversion from natural gas to propane.

Note: Please keep these instructions for future reference.

Buderus

Please read carefully before conversion

1	Safety	3
1.1	Correct use	3
1.2	Notes structure.	3
1.3	Please observe these notes.	3
2	Scope of delivery	3
3	Conversion of the boiler at altitudes over 8500 feet	4
4	Start-up instructions	8
4.1	Making boiler ready for operation	9
4.2	Then carry out start-up procedures.	10

1 Safety

Observe these instructions for your safety.

1.1 Correct use

The conversion kit is for conversion of the G334 X gas-fired boiler for operation at altitudes above 8500 feet.

1.2 Notes structure

Additional symbols for identification of dangers and user instructions.



WARNING!

RISK TO LIFE

Identifies possible dangers emanating from a product, which might lead to serious injury or death if appropriate care is not taken.



WARNING!

RISK TO LIFE

from electric shock.



USER NOTE

Tip for the optimum utilization and setting of the control(s) plus other useful information.

1.3 Please observe these notes



WARNING!

RISK TO LIFE

from explosion of flammable gases.

- Never work on gas lines unless you are licensed for this type of work.



WARNING!

RISK TO LIFE

from electric shock.

- Disconnect the power supply to the heating system before conducting any work on it, e.g. switch off the heating emergency switch outside the boiler room.
- It is not sufficient just to switch off the control.

2 Scope of delivery

The conversion kit for high altitudes includes the following components:

- main gas orifices and seals
- conversion date label (to be filled out and attached to the unit)
- conversion instructions
- Technical documents

3 Conversion of the boiler at altitudes over 8500 feet

Read the instructions before conversion for your safety.



WARNING!

RISK TO LIFE

due to not observing the attached conversion instructions.

- If you wish to convert the boiler for operation with propane, the conversion from natural gas to propane must be carried out first as specified by the attached conversion instructions. The conversion for high altitudes can only be made after this.

When converting the boiler for operation at high altitudes observe the following directions:

The boiler must be converted before installation.

1. If the boiler has been operating, close the gas valve. Otherwise continue with step 3.
2. Disconnect heating system from the power supply and set the thermostat to the lowest setting.
3. Remove safety screws from the left and right side panels, then lift the front panel of the boiler and pull it forward.

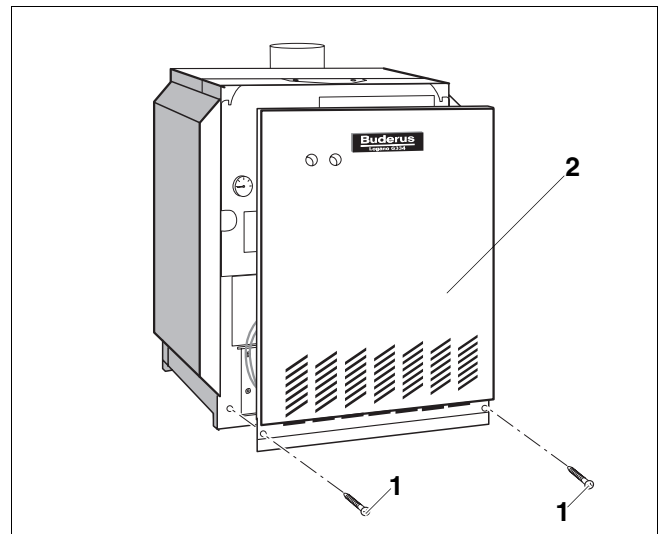

Fig. 1 Removing front panel of boiler

1 Screws

2 Boiler front panel

4. Turn gas valve ON/OFF button clockwise to OFF position. Do not use force.

**RISK TO LIFE**

from explosion of flammable gases.

WARNING!

- Wait five (5) minutes until all gas residues have dissipated. Check whether there is any smell of gas, including at floor level. If there is a gas odor: STOP! Follow instructions in section "B" of the safety instructions on page 8. If there is no sign of a gas odor, continue with the next step.

Replacing main gas orifices**USER NOTE**

When converting the boiler for high altitudes it is only necessary to replace the main gas orifices, not the pilot gas orifice.

5. Disconnect pilot gas line from gas valve.
6. Disconnect ignition cable from automatic ignition.
7. Tie gas line with wire or cord (secure).
8. Unscrew retaining screws of gas feed line at burner. Place the gas connection pipe gasket in a safe place.
9. Check gasket for damage and replace if damaged.

**RISK TO LIFE**

due to incorrectly connected wiring.

WARNING!

- When conducting maintenance work label all cables before disconnecting them.

10. Label connection lines of flame roll-out switch and disconnect from the flame roll-out switch.

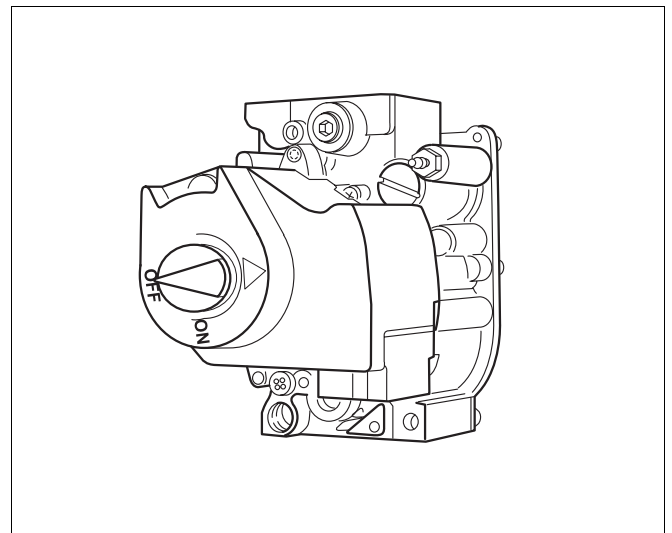

Fig. 2 Gas valve

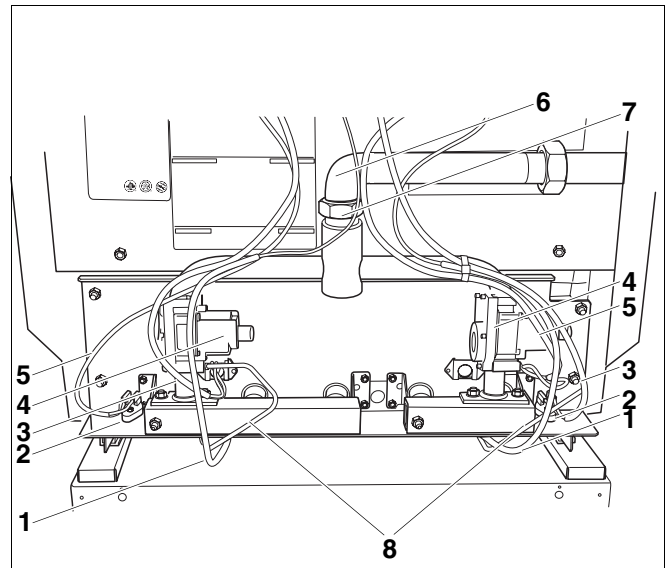

Fig. 3 Front view

- 1 Ignition cable
- 2 Flame roll-out switch
- 3 Connection lines to the gas valve
- 4 Gas valve
- 5 Connection lines to the flame roll-out switch
- 6 Gas supply line
- 7 Retaining screw on the gas feed line
- 8 Pilot gas line

11. Unscrew retaining nuts on burner plate and pull gas burner straight out.
12. When removing the burner make sure that the spacers remain on the studs.
13. Install the new main gas orifices and copper gasket. Check with → Tab. 1 and → Tab. 2 to ensure that the correct orifices for operation of the boiler are installed.

Orifice sizes for natural gas		
Altitude in feet		
Model	0–8500	8501–12000
G334 X-73	3.60	3.55
G334 X-92	3.70	3.65
G334 X-116	3.90	3.85
G334 X-132	3.90	3.85

Tab. 1 Orifice size for natural gas

Orifice sizes for propane		
Altitude in feet		
Model	0–8500	8501–12000
G334 X-73	2.35	2.30
G334 X-92	2.40	2.35
G334 X-116	2.50	2.45
G334 X-132	2.50	2.45

Tab. 2 Orifice size for propane

14. Install gas burners in boiler in reverse order of removal. Tighten the fixing nuts well.
15. Tighten the screws (→ Fig. 3, page 5) between the gas valve and the burner again. Make sure that the connection pipe gasket removed in step 8 is replaced.
16. Check gasket for damage and replace if damaged.
17. Attach connection lines for the flame roll-out switch.
18. Remove wire or rope that was used to hold the gas supply line in step 7.
19. Connect ignition gas line (→ Fig. 3, page 5) to the gas valve again.
20. Connect ignition cables (→ Fig. 3, page 5) to the automatic igniters.
21. Enter the required information on the conversion label and attach on the outside of the boiler jacket as close as possible to the name plate.

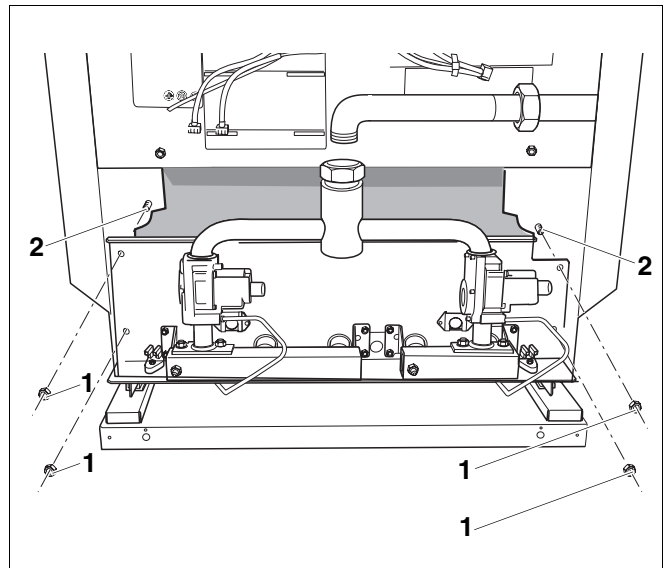

Fig. 4 Removing burner

1 Fixing nuts

2 Threaded studs

Carrying out leak test**USER NOTE**

The boiler has two gas valves. Make all measurements and adjustments on both gas valves.

22. Open gas valve in the gas line.**SYSTEM DAMAGE**

due to short-circuit.

CAUTION!

- Cover the hazardous locations before checking for leaks.
- Do not spray the leak solution on wiring openings, plugs or electrical connections. Do not allow the solution to drip on these locations.

23. Check the gas connection line to the gas valve for leaks with soap solution. If no leaks are found, continue with step 25. If any leaks are found, close gas valve.

24. Seal leaks and repeat step 23.

25. Close main gas valve. Remove the screw plug for the gas connection port on the gas valve. Install pressure measuring nipple and attach a pressure gauge to measure the gas pressure.

26. Remove the screw plug for the manifold pressure port on the gas valve. Install pressure measuring nipple and attach a pressure gauge to measure the manifold pressure.

27. Open gas valve and measure the gas pressure of the boiler. The supply pressure for natural gas must be between 7" and 10.5" W.C. and between 11" and 13" W.C. for propane gas. If the supply pressure for natural gas is not between 7" and 10.5" W.C. and not between 11" and 13" W.C. for propane gas, contact the customer service technician or the gas company.

28. Always follow the start-up instructions on the next page.

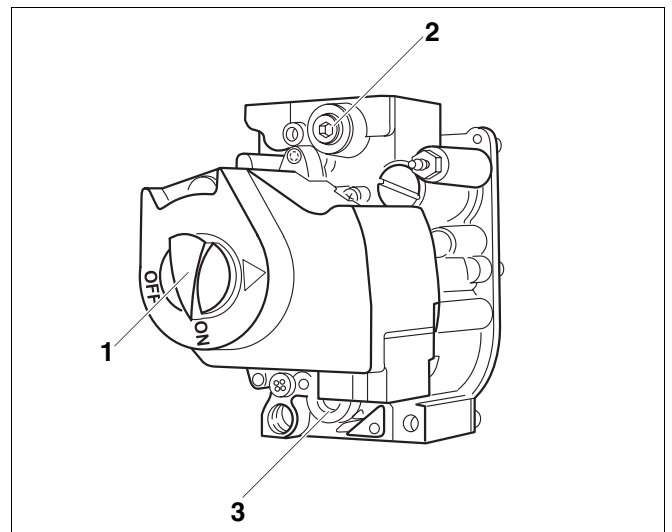

Fig. 5 Gas valve

- 1 ON/OFF button (at ON position)
- 2 Screw plug for gas supply pressure measuring port
- 3 Screw plug for manifold pressure measuring port

4 Start-up instructions

Read the instructions before start-up for your safety.



WARNING!

RISK TO LIFE

due to not observing the start-up instructions and resulting incorrect operation.

- If these instructions are not followed exactly, a fire or explosion may be caused with serious property damage or loss of life or serious injury.
- Observe the start-up instructions.



WARNING!

DANGER OF EXPLOSION

If you smell gas there is a danger of explosion.

- No open flame. No smoking.
- Prevent spark formation.
Do not operate electrical switches, including telephones, plugs or door bells.
- Shut off main gas supply valve.
- Open doors and windows.
- Warn other occupants of the building.
- Evacuate the building.
- Call gas company or fire department from outside the building.

- A** This unit is equipped with an igniter that automatically starts the pilot burner. Do not attempt to ignite it manually.
- B** Check for an odor of gas around the heating system. This test must also be conducted at floor level, because some types of gas are heavier than air and may accumulate at floor level.
- C** Switch on the ON/OFF switch on the gas valve by hand only. Never use a tool as assistance. If you cannot actuate the ON/OFF switch on the gas valve by hand, do not attempt to repair it. Contact a qualified technician. Any attempt to use force or to repair the switch may cause a fire or explosion.
- D** Do not operate the unit if any part is under water. Contact a qualified customer service technician immediately to have the unit checked and to replace the parts of the control and gas valves that were under water.

4.1 Making boiler ready for operation

STOP! First read the safety instructions on → page 8 of this manual.

1. Carry out leak test (→ page 7). Wait five (5) minutes until all gas residues have dissipated. Finally check whether there is any smell of gas, including at floor level. If there is a gas odor: STOP! Follow instructions in section "B" of the safety instructions on → page 8 of this manual. If there is no sign of a gas odor, continue with the next step.
2. Open main gas valve.

4.1.1 Placing heating system with aquastat control in operation

The boiler is fully functional with the factory-installed aquastat.

3. Switch on ON/OFF switch (building side) (ON position). This switches on the boiler with all its components. Then continue with step 7.
4. Make sure that the room thermostat signals a heat requirement (set thermostat at least 10 °F above room temperature).

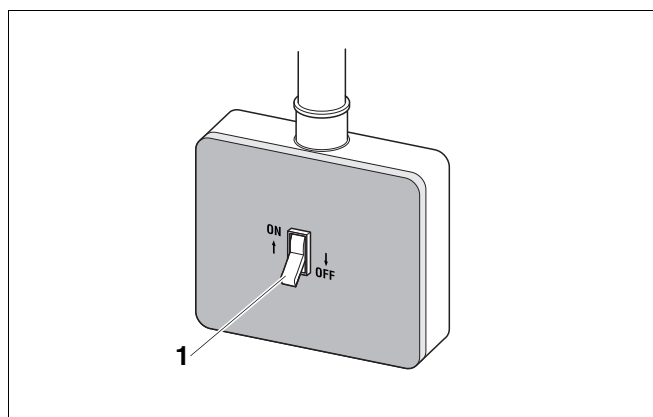

Fig. 6 Switching on heating system (with aquastat)

1 ON/OFF switch (main switch)

4.1.2 Placing heating system with Logamatic 2107 (accessory) in operation

The boiler is fully functional with the factory-installed aquastat. The Logamatic 2107 control can also be installed in addition to the factory-installed aquastat.

Switch on the heating system with the ON/OFF switch on the control. The burner starts operating if heat is required (→ observe control service manual).

5. Make sure that heat is required at the control. Select "Manual operation" (hand symbol) with the mode selector switch.
6. Switch on ON/OFF switch ("I" position). Then continue with step 7.



USER NOTE

After carrying out the instructions for starting described below, the control must be set to "AUT" mode (automatic operation) with the mode selector.

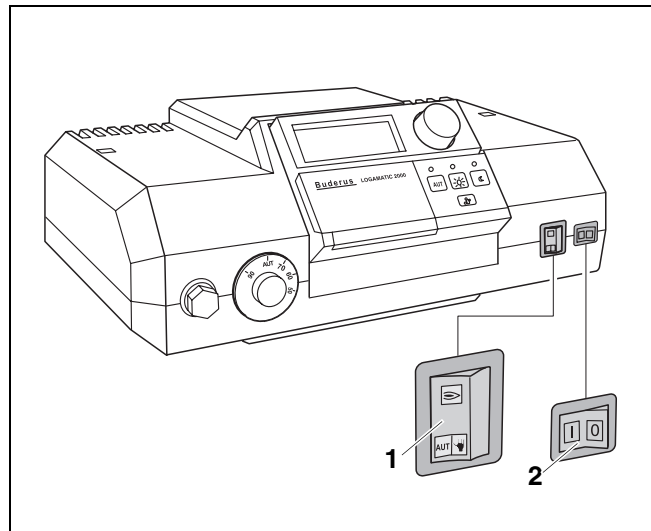

Fig. 7 Switching on heating system (with Logamatic 2107 control)

- 1 Mode selection switch
- 2 ON/OFF switch

4.2 Then carry out start-up procedures.

The following start-up procedures must be carried out regardless of the control type.

7. Look at the igniter through the sight glass in the burner housing.

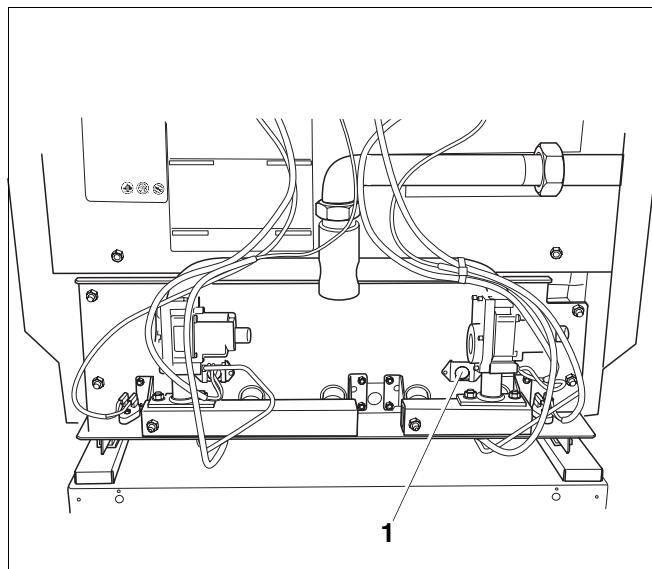

Fig. 8 Front view

- 1 Sight glass

8. Turn gas valve ON/OFF switch counterclockwise to ON position.
9. The automatic igniter must generate sparks towards the pilot burner. The pilot flame must appear and then ignite the main burner. If the main burner does not ignite, close the gas valve. Disconnect heating system from the power supply and inform your customer service technician or gas company.
10. If the main burner has ignited, the gas valve must be checked for leaks with soap solution. If no leaks are found, continue with step 12. If leaks have been found, switch ON/OFF switch on gas valve clockwise to the OFF position. Disconnect heating system from the power supply and set the thermostat to the lowest setting.
11. Seal leaks. Repeat steps 1 and 2 (regardless of the control in use).

Caution:

With aquastat control continue with steps 3 and 4, with the Logamatic 2107 continue with steps 5 and 6.

Then repeat steps 7 to 10 regardless of the control in use.

12. Check the gas supply pressure at the connection while the boiler is operating. The connection pressure for natural gas must be between 7" and 10.5" W.C. and between 11" and 13" W.C. for propane gas. Record the measured values in the commissioning protocol in the installation and maintenance instructions.

G334 X	Natural gas inch W.C.	Propane inch W.C.
73	4.4	10.4
92	4.4	10.3
116	4.1	10.3
132	4.2	10.2

Tab. 3 Manifold pressure

13. Check manifold pressure. The manifold pressure must be set in accordance with the values in → Tab. 3. To set the manifold pressure the cover (→ Fig. 9) on the gas valve must be removed. Turn the adjustment screw clockwise to increase the pressure and counterclockwise to reduce the pressure. This setting must be adjusted while the boiler is operating.
14. Record the set value in the commissioning protocol of the installation and maintenance instructions and screw the safety screw (→ Fig. 9, page 11) into the gas valve again.

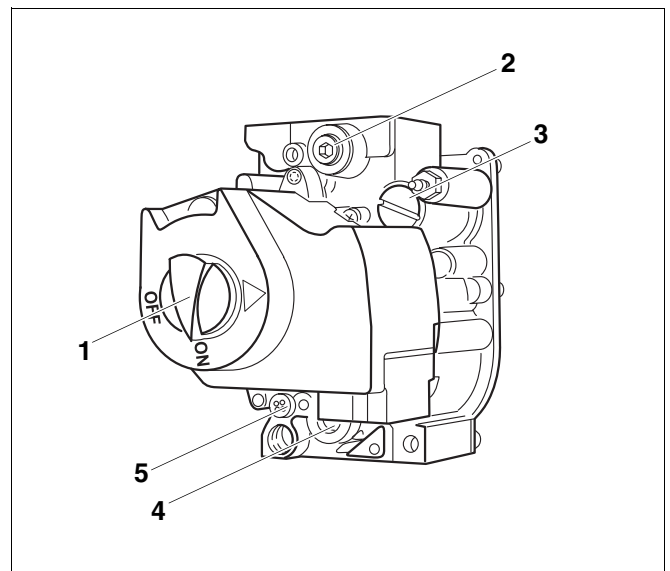

Fig. 9 Gas valve

- 1 ON/OFF button (at ON position)
- 2 Screw plug for gas supply pressure measuring port
- 3 Safety screw for manifold pressure setting
- 4 Screw plug for manifold pressure measuring port
- 5 Safety screw for igniter pilot burner setting

15. Observe pilot flame through the sight glass (→ Fig. 8, page 10) in the burner housing.
16. The flame must envelope the flame guard 1/2 to 1 1/2 inches. If this is the case continue with step 20.
17. If the pilot flame is too small or too large, the pressure for the pilot burner must be adjusted with the corresponding adjustment screw.



USER NOTE

The adjustment screw is behind the pilot burner pressure adjustment safety screw (→ Fig. 9, page 11).

18. Remove safety screw for pilot burner pressure setting (→ Fig. 9, page 11). Turn the inner adjustment screw clockwise to reduce the pilot flame and counterclockwise to enlarge the pilot flame.
19. After adjustment tighten the pilot burner pressure adjustment safety screw (→ Fig. 9, page 11) again.
20. Observe main burner flame through the sight glass (→ Fig. 8, page 10) in the burner housing. The flame must have a steady and fixed contour and generally has a bluish color. If the main burner flame meets the requirements, proceed with step 21. If the main burner flame is too weak or is yellow or goes out, turn the ON/OFF switch (→ Fig. 9, page 11) on the gas valve clockwise to OFF. Close the gas valve and disconnect the heating system from the power supply and contact the customer service technician or the gas company.

Checking ignition safety switch

21. Test the safety switch by closing the gas valve. The main burner flame (→ Fig. 11) and the pilot flame (→ Fig. 10) are extinguished. After six (6) seconds at the most the main gas solenoid valve on the gas valve must close with an audible noise.
22. After 90 seconds the automatic igniter must switch to lock status and stop generating sparks.
23. Disconnect the heating system from the power supply. Open main gas valve. Switch on unit power supply. A normal operating cycle must follow.
24. If the gas valve operates correctly, proceed to step 25. If the gas valve does not operate correctly, switch ON/OFF switch (→ Fig. 12) on the gas valve clockwise to the OFF position immediately. Close main gas valve. Disconnect heating system from the power supply and inform the customer service technician or gas company.

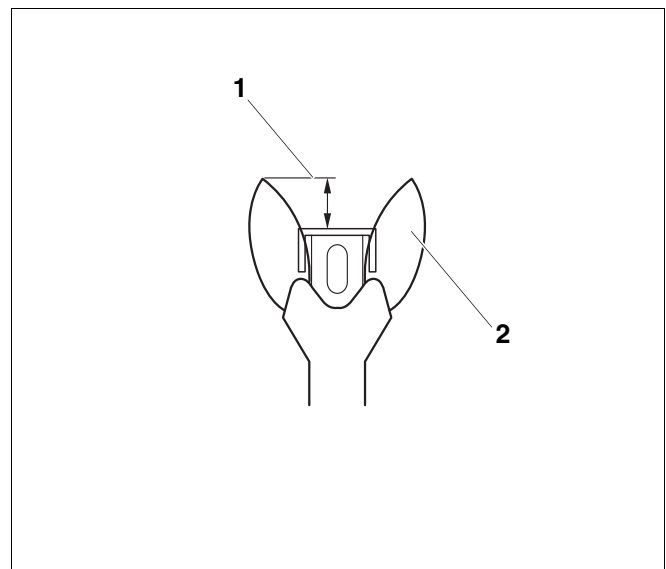

Fig. 10 Correct pilot flame setting

1 1/2 to 1 1/2 inches

2 Pilot flame

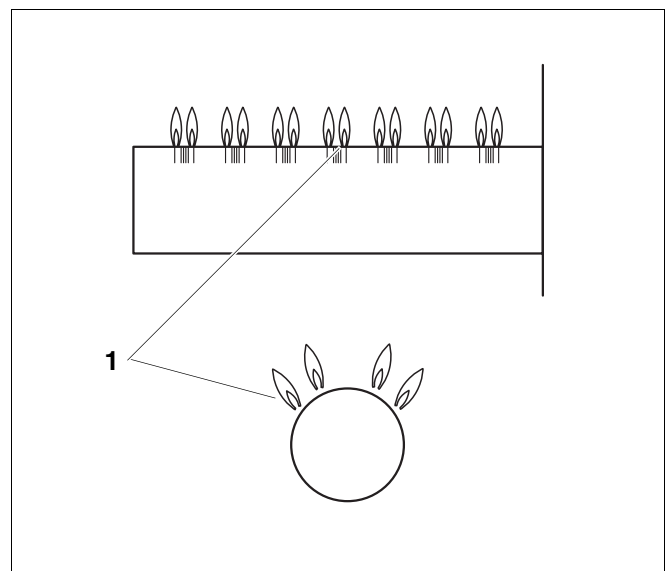

Fig. 11 Main burner

1 Main burner flame

25. Turn gas valve ON/OFF button clockwise to OFF position.
26. Close main gas valve.
27. Disconnect heating system from the power supply and set the thermostat to the lowest setting.
28. Remove pressure measuring nipple and pressure gauge for measuring gas supply pressure and manifold pressure from the gas valve and close the openings with the screw plugs.
29. Repeat steps 1 to 10 (depending on the control) and 20 to restart the heating system. Check the screw plugs for leaks with soap solution. If no leaks are found, continue with step 31. If leaks are found, close gas valve and switch ON/OFF button on gas valve clockwise to the OFF position. Disconnect the heating system from the power supply.
30. Seal leaks. Open gas valve and repeat step 24.
31. Carefully wipe away the soap solution to prevent corrosion caused by the alkali content of the soap.
32. Check the function of the maximum aquastat to make sure that it switches off the boiler as soon as the boiler water temperature set at the aquastat or the Logamatic 2107 control is reached. Record the result in the commissioning protocol of the installation and maintenance instructions.
33. Replace front panel of boiler.

With the Logamatic 2107 control only

34. Select AUT (automatic mode) with the mode selection switch.

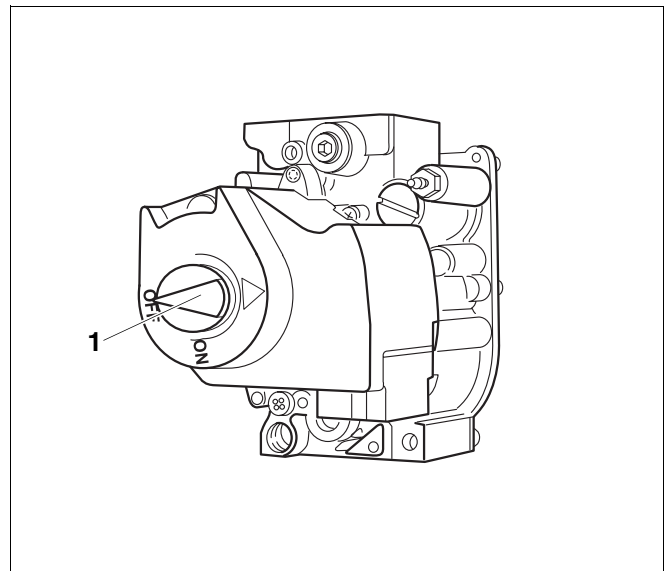

Fig. 12 Gas valve

1 ON/OFF button (at OFF position)

Heating Contractor:

PRODUCTS MANUFACTURED BY

BBT Thermotechnik GmbH
35573 Wetzlar
www.buderus.de

Buderus

BBT North America Corporation
50 Wentworth Avenue
Londonderry, NH 03053
Tel: 603-552-1100 • Fax: 603-584-1681
www.buderus.net

*BBT North America Corporation reserves the right to make changes without notice
due to continuing engineering and technological advances.*