

GB312/90 Gas Condensing Boiler

GB312/90 Performance Data	
Gas Input (MBH)	328.3
Gross IBR Output (MBH)	305
Input at Minimum Capacity (MBH)	132
Output at Minimum Capacity (MBH)	131
Net IBR Rating (MBH)	265
Thermal Efficiency	93.1%
Combustion Efficiency	93.4%
Boiler Horse Power	9.1

GB312/90 Operational Data	
Number of Heat Exchanger Sections	4
Dry Weight (lbs.)	455
Approx. Water Content (gal.)	4.2
Min Inlet Gas Pressure NG ("WC)	3.5
Max Inlet Gas Pressure NG ("WC)	10.5
Max High Limit Temperature (°F)	200°F
Fireside Pressure Drop (Inch WC)	0.49
Flow Rate at 18°F ΔT (GPM)	30
Flow Rate at 36°F ΔT (GPM)	15
Max Working Pressure (psi)	50
Relief Valve Rating (MBH)	1,418
Relief Valve Pressure Rating (psi)	50
Max Flow Temp Heating/DHW (°F)	172/180
Max equivalent exhaust vent length (ft)	100
Max equivalent combustion air vent length (ft)	100
Venting Category	IV
Approved Venting Materials	CPVC ^{1, 2} , AL29-4C

¹ The following system is approved for use in U.S.A and may be used with this boiler:

Spears - CVPC pipe to Schedule 80 ASTM D1784

² The following system is approved for use in Canada and may be used with this boiler:

IPEX - System 636 CPVC (available in 4" only)

GB312/90 Electrical Specifications	
Electrical Voltage Mains	120V/60Hz
Electrical Voltage Controls	24V
Power Consumption Max Load (A)	0.7
Power Consumption Min Load (A)	0.33
Max Permissible Fuse Rating (A)	10

GB312/90 Clearances		
	Minimum Clearance to Combustibles (Inch)	Wall Clearance Recommended (Inch)
Front	20	28
Rear	22	28
Side	20	28
Flue pipe to wall	6	14

Additional Information

- Outdoor reset AM10 standard with outdoor sensor
- DHW priority MC10/BC10 standard (DHW sensor not included)
- Modulating premix burner
- Direct-vent sealed combustion
- Direct ignition by hot surface igniter
- Adjustable leveling legs
- 50 psi relief valve

Options

- CSD-1 kit (high gas pressure switch / low gas pressure switch)
- Condensate neutralization tank (NE-0.1)
- Logamatic 4323 Control
 - Sequencing up to 8 boilers
 - System and zoning control for pumps and valves
 - solar integration
 - plate and frame heat exchanger control
- CM10 two boiler module
- EM10 BMS integration 0-10V input stand alone control
- Low water cutoff
- High temperature manual reset
- DHW sensor

Note: Refer to applications manual for specific information on venting, piping, electrical connections and pump sizing.

GB312/90 Piping Connections/Specifications

ØAA	Flue Connection Diameter	6"
AL	Combustion Air Pipe Diameter	4"
AG	GAS Connection Size	1" NPT
RK/VK	Boiler Return & Supply Connections	2½" NPT
ST	Relief Valve Connection (B-kit)	¾" NPT

GB312 B-Kit Assembly with Flow Check Valve

ITEM	DESCRIPTION	QTY
1	2½" Flange to boiler	2
2	½" Female NPT	1
3	¾" Female NPT	3
4	¾" Female NPT	1
5	1" Female NPT	1
6	2½" - Check Valve	1
7	2½" - Female NPT Mating Flange to system	1

GB312 B-Kit Assembly with Flow Check Valve

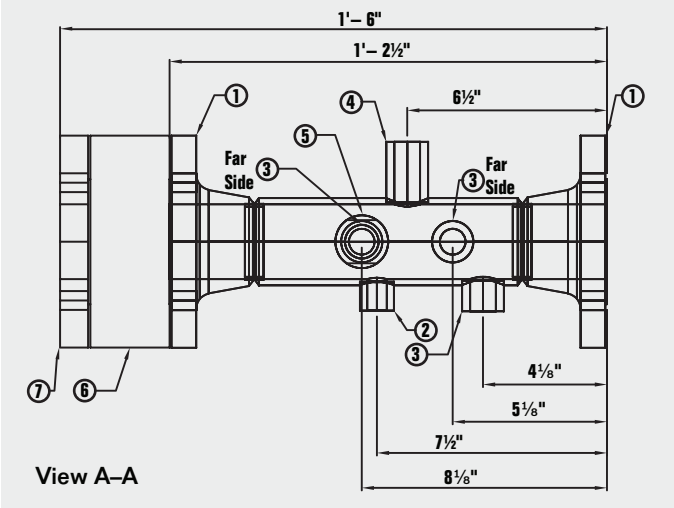

GB312/90 Top View

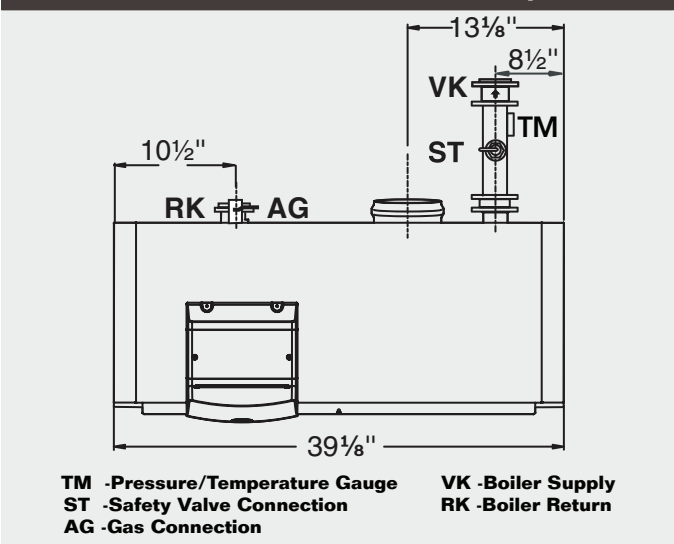

GB312/90 Rear View

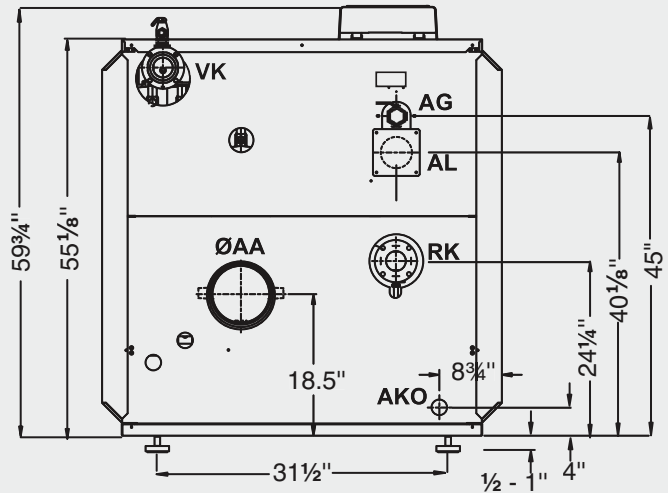

VK -Boiler Flow
ØAA -Flue Connection
AKO -Condensate Drain Knock Out
AG -Gas Connection
AL -Combustion Air Pipe
RK -Boiler Return

GB312/90 Side View

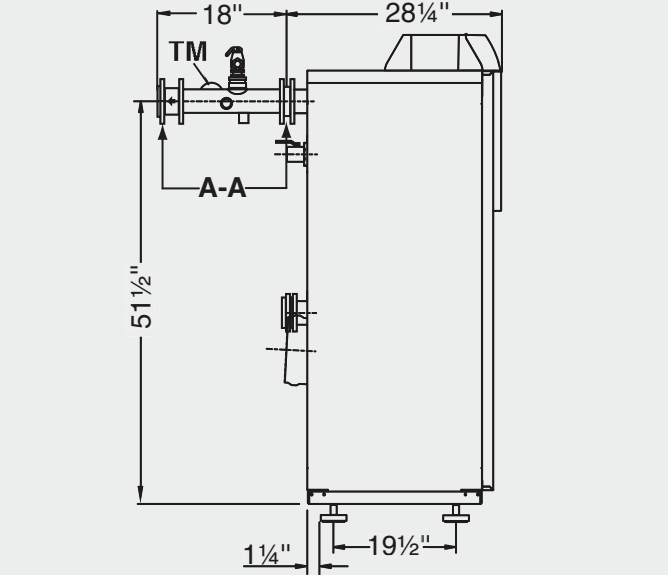

TM -Pressure/Temperature Gauge
A-A -B-Kit Assembly with Flow Check Valve

Buderus

Bosch Thermotechnology Corp.
 50 Wentworth Ave
 Londonderry, NH 03053
 Tel: (603) 882-1100
 Fax: (603) 584-1681
 www.buderus.net