

Assembly, Maintenance and Operating Instructions

Buderus G315 Boiler

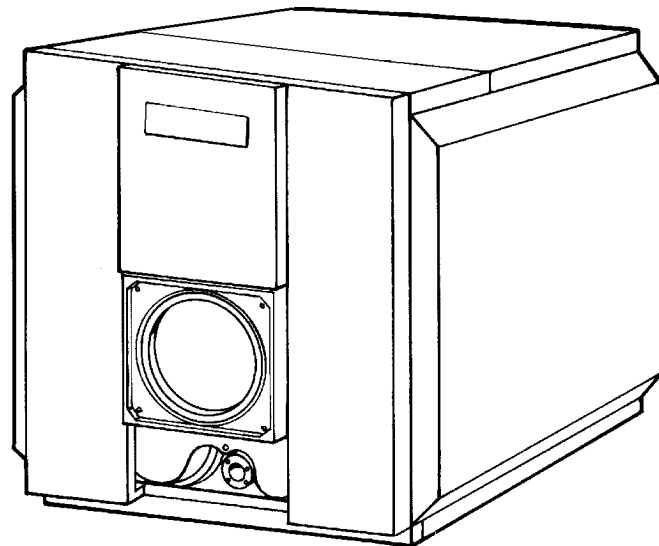

G315

Save These Instructions!

This assembly, maintenance and operating manual must be kept near the boiler!

TABLE OF CONTENTS

1	General Guidelines	3
2	Boiler Operating Data	4
3	Technical Data	5
4	Boiler Foundation and Minimum Boiler Clearances	6
5	Assembly Tools/Tools Req'd for Boiler Assembly	7
6	Boiler Assembly	8-11
7	Hydrostatic Test	12
8	Installation of Boiler Components	13-15
9	Installation of Insulation & Boiler Jacket Panels	16-19
10	Installation of Hydronic Control Components	20
11	Maintenance Instructions	21-23
12	Optional Noise Reduction Equipment	24
13	Shipping Component Listing	25
14	Supply Temperature Control	26

General guidelines

Installation, maintenance and service of this boiler must only be carried out by a qualified contractor. The assembly sequence is essential to reliable operation of the boiler and associated heating system. The boiler can be assembled, hydrostatically tested and operated without boiler insulation and jacket panels. These items can be installed at a later date without disrupting boiler operation.

NOTE: A minimum **supply** temperature of 122° F must be maintained during burner operation. Controls must be provided that will shut off circulation through the boiler when the **supply** temperature drops below 122° F. This requirement applies **only** during burner operation. There is no minimum return water temperature requirement.

All work shall be performed in strict accordance with the requirements of state and local regulating agencies and codes dealing with boiler installations. Initial start-up must be performed by qualified personnel. After start-up the owner or its representative should be instructed about the boiler operation and be given the assembly and maintenance manual.

Boiler cleaning and maintenance must be carried out once annually. This includes an overall check of the heating system. Any discrepancies must be corrected immediately.

NOTE: To perform the hydrostatic pressure test after the boiler is assembled, 2 - 2" or 3" caps, 3/4", 1" and 2" plugs and a 3/4" air vent may be needed. These items are *not* furnished with the boiler.

NOTE: This manual is for reference only. The manual does NOT purport to address all design, installation and safety considerations. It is the responsibility of the user of this manual to determine the applicability and safety of each individual application and ensure its compliance with local building codes.

It is expected that the user/installer is a licensed heating contractor with knowledge of accepted industry practices for the installation and maintenance of the equipment and various applications of the equipment involved.

2 Boiler Operating Data

Boiler operating ratings

Maximum supply temperature: 248°F (120°C)
Maximum operating pressure: 58 psi (4 bar)

Water quality requirements

Fill water requirement: water with alkalinity < 200 mg/li for initial system filling.

Make-up water requirement: water with alkalinity < 30 mg/li

System water requirements:

pH value (@ 77°F):	9.0 - 10.0
Acid capacity:	3.0 - 50 mg/li
Oxygen (O ₂):	.01%
Phosphate (P ₂ O ₅):	2.5 %
Sodium sulfate (Na ₂ SO ₃):	1 - 4%

For overall system protection, it is recommended to install a filter and sludge removal system in the boiler return piping.

Any approved (based on application testing at burner manufacturer's facilities) oil or power gas burner can fire into G315 boilers. Burners with low fire start or two stage firing are recommended. The high fire setting on the burner should match the rated output of the boiler to prevent condensation in the heat exchanger. The CO volume percent in undiluted, dry flue gas should not exceed .04% (400 ppm).

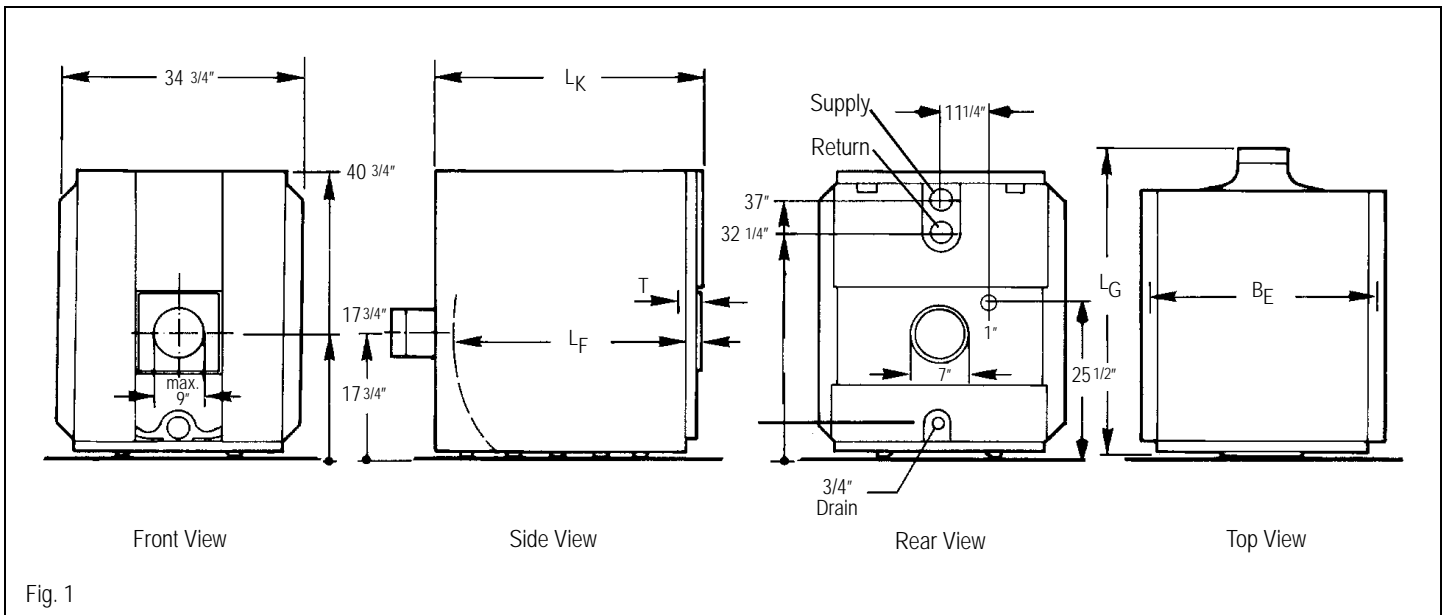

Table 1: Boiler Dimensions

Gross Output (Btu/hr.)	358,000	478,000	580,000	682,000	785,000
No. of Sections	5	6	7	8	9
Overall Boiler Length L _G (In.)	44 1/4	50 1/2	56 3/4	63 1/4	69 1/2
Boiler Block Length L _K (In.)	38 1/4	44 1/2	50 3/4	57	63 1/2
Minimum Boiler Width B _E (In.)	28	28	28	28	28
Fire Box Depth L _F (In.)	31	37 1/2	43 3/4	50	56 1/4
Fire Box Diameter (In.)	15 3/4	15 3/4	15 3/4	15 3/4	15 3/4
Fire Box Volume (Cu.Ft.)	5.19	6.39	7.59	8.79	9.99
Dry Weight (Lbs.)	1197	1391	1585	1779	1973
Water Content (Gals.)	37.8	45.2	52.6	60.0	67.4
Operating Weight (Lbs.)	1512	1768	2024	2280	2535
Vent Connection Size (In.)	7	7	7	7	7
Door Thickness T (In.)	5	5	5	5	5

Table 2: Technical Specifications

Gross Output (Btu/hr.)	358,000	478,000	580,000	682,000	785,000
No. of Sections	5	6	7	8	9
Boiler HP	10.7	14.3	17.4	20.4	23.5
Net IBR Rating (Btu/hr.)	311,000	416,000	504,000	593,000	683,000
Max Input Oil (GPH)	3.0	3.85	4.7	5.5	6.4
Max Input Gas (Btu/hr.)	420,000	540,000	660,000	770,000	896,000
Fire side heating surface (Sq.ft.)	50.6	62.4	74.3	86.1	96.9
Firebox Pressure (In. W.C.)	.18	.32	.50	.71	.75

4 Boiler Foundation and Minimum Boiler Clearances

Boiler foundation preparations

It is required that the boiler is placed on a level, smooth concrete base, of sufficient strength. The width of the platform must be 33 1/2". Length L₁ is the platform length. It is required to cement in either a 4" x 1/4" flat steel plate or a 4" x 2" x 1/4" angle iron, as shown in Figure 2; Table 3 shows dimensions.

Table 3: Foundation and support strip lengths

No. of Sections	Length L1 (In.)	Length L2 (In.)
5	36	28 3/4
6	42 1/4	35
7	48 1/2	41 1/4
8	54 3/4	47 1/2
9	61	54

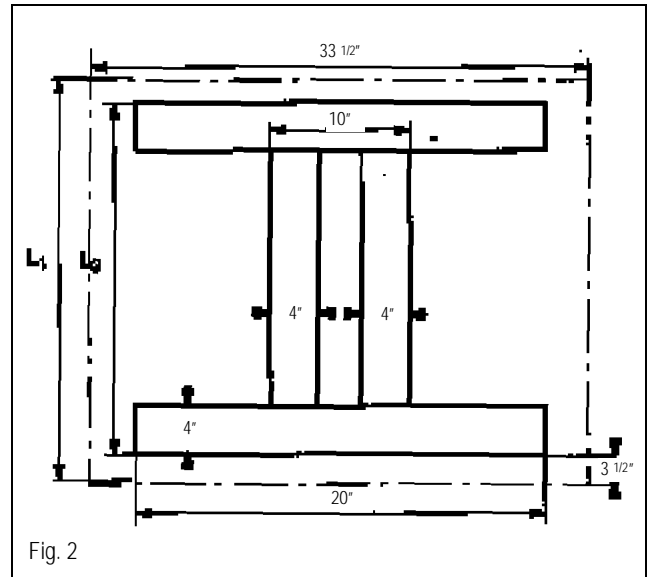

Fig. 2

Minimum wall clearances

The recommended wall clearances must be observed in order to open the burner door, assemble the boiler and allow sufficient access for boiler maintenance. (See Figures 3 and 4 for details).

The burner door is field adjustable to hinge right or left.

Recommended clearances:

- Wall clearance W1: minimum 12".
- Wall clearance W2: Burner length A + 4", minimum 43".
- Wall clearance W3: Boiler length L + 40".
- Wall clearance W4: 1/2 Boiler length + 20".

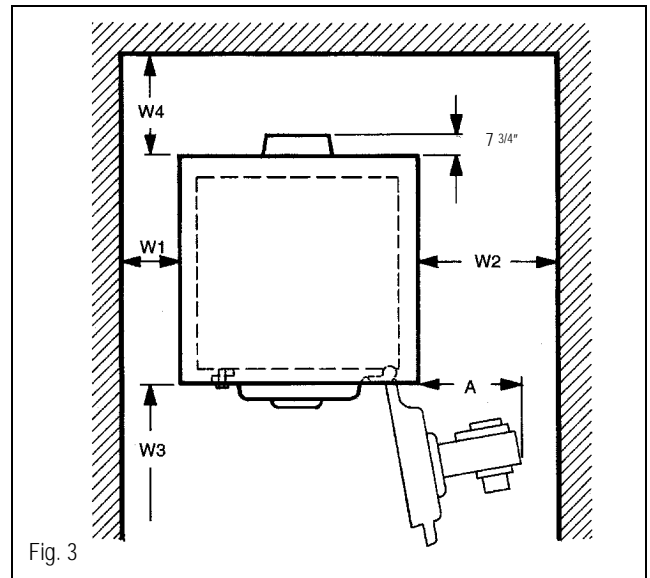

Fig. 3

Absolute minimum clearances:

- Wall clearance W1: minimum 12".
- Wall clearance W2:* minimum 12".
- Wall clearance W3: Boiler length L or minimum 86".
- Wall clearance W4: 36".

Note: Wall clearance W3 can be reduced to 4 feet for assembled boilers. Boiler cleaning will now require use of segmented brushes.

*Requires burner removal during cleaning.

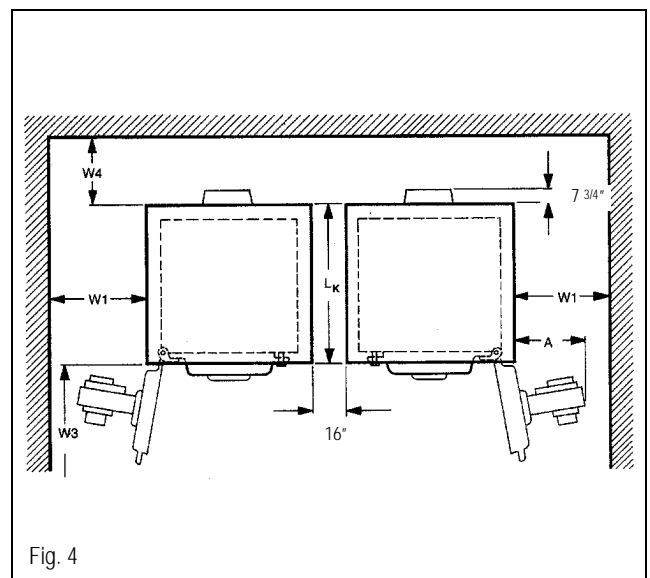

Fig. 4

Assembly Tools/Tools Req'd for Boiler Assembly 5

Assembly tools and auxiliary assembly materials

- ✓ Boiler assembly tool rods size 2.2 (2 pieces)
- ✓ Wooden or rubber mallet
- ✓ Half-round rough file
- ✓ Flat head and Phillips screwdrivers
- ✓ Flat chisel, steel strips for boiler support
- ✓ Metric wrenches sizes 13, 19, 24, 36 and socket size 19 (US equivalent sizes may also be used)
- ✓ Cleaning rags, machine oil, gasoline or paint thinner, level, steel wire brush, tape measure, chalk.

chalk.

Boiler assembly tool components

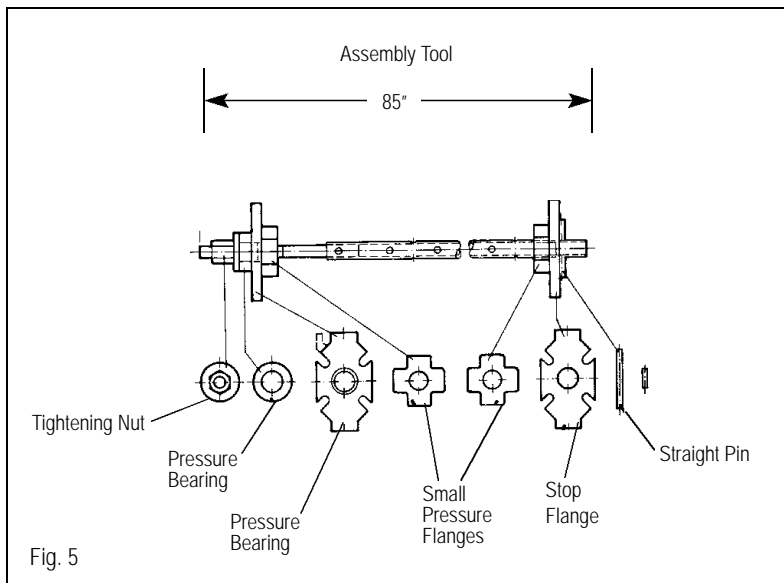

Table 4. Assembly tool requirements

No. of Sections	Assembly Tool	Extension Piece	Total Tool Length (ft)
5-9	1	0	7

6 Boiler Assembly

Boiler block sectional arrangement

The boiler is always assembled starting with the rear section and finishing with the front section.

The arrow markings on the sections must point to the rear (Fig. 6) and use the sequence in Table 5.

Table 5: Boiler section arrangement

Model	No. of Front Section	No. of Midsections	No. of Rear Section
315/5	1	3	1
315/6	1	4	1
315/7	1	5	1
315/8	1	6	1
315/9	1	7	1

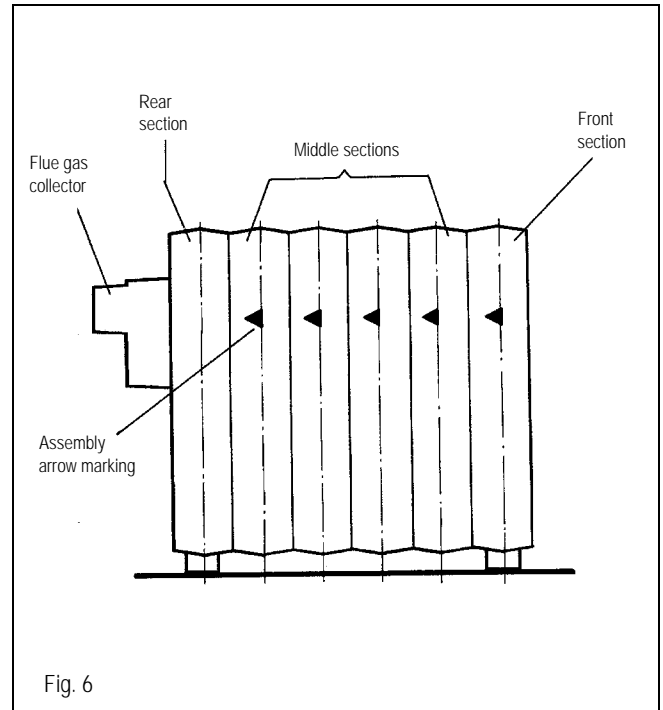

Assembly of individual boiler sections

- Remove the nuts and washers from the rear and front sections prior to boiler assembly.
- Note the arrow marking on each section. These arrows are located on the top left and right of each section and must point to the rear during boiler assembly (Fig. 6).
- Assemble the boiler on a smooth hard surface with flat steel plates underneath to permit easy sliding of sections.
- Position and align the rear section upright in final location and secure it from falling over (Fig. 7).
- To reduce the risk of injuries, support the boiler section or secure it with an overhead lifting device.

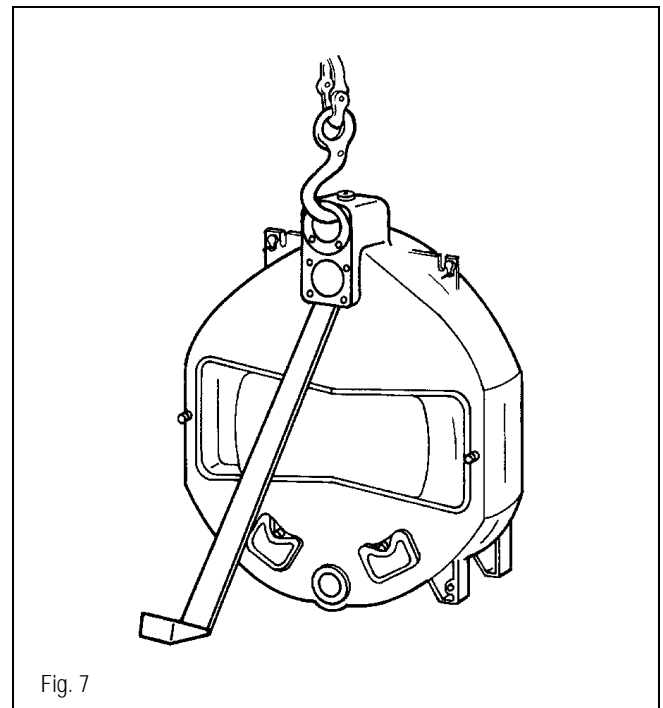

CAUTION: The work area must be well ventilated during boiler assembly .

WARNING: Keep Buderus Haftgrund 181 primer away from flame! Do not smoke during assembly! *Do not* pour Buderus Haftgrund 181 primer down open drains!

- File off any burrs from the nipple ports (Fig. 8).
- Clean the sealing surfaces of the nipple ports with a rag soaked in thinner or gasoline. Wipe dry.
- Evenly coat the nipple port sealing surfaces with the orange sealing compound (Leinolmennige) using the brush provided (Fig. 9).
- Clean the sealing grooves for sealing the flue side of the boiler using a steel wire brush. Make sure surfaces are dry, clean and free of any oily residues.
- Apply the Buderus Haftgrund Primer 181 to all sealing grooves using a small paint brush (Fig. 10).
- The sealing of the flueway of each section is achieved with the sealing cord. The sealing cord can be installed 5 to 15 minutes after the application of the primer.

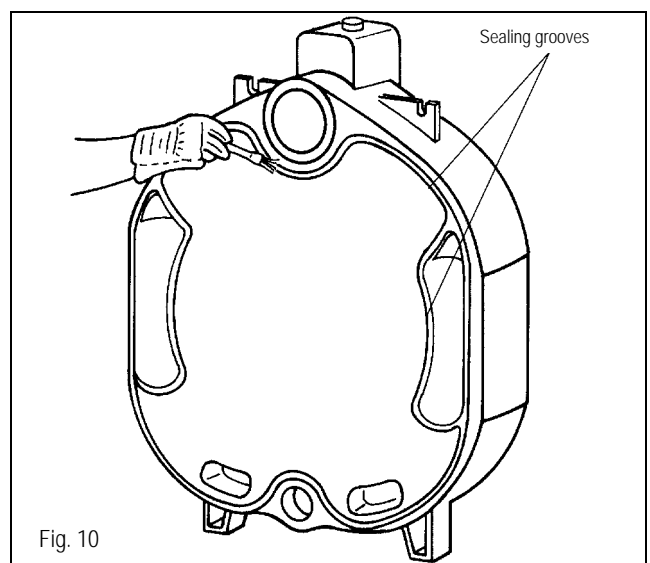
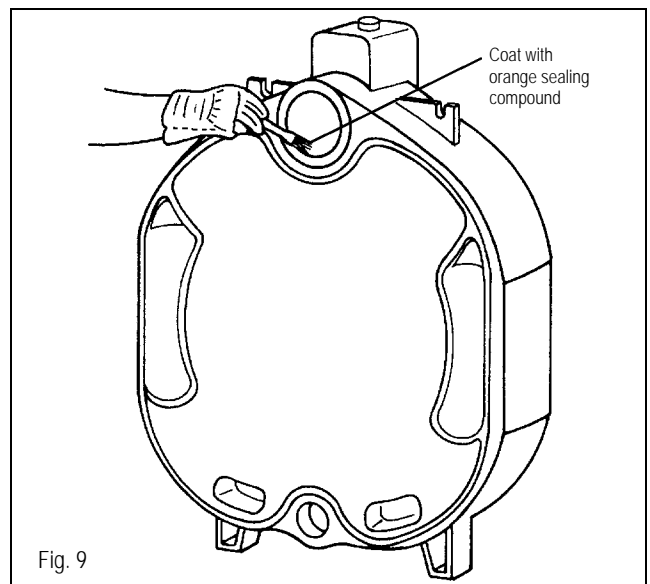
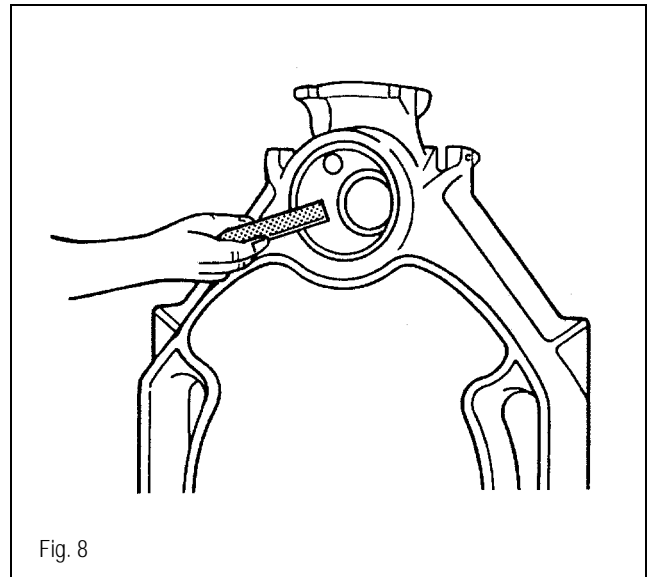

6 Boiler Assembly

- Insert the elastic sealing cord (“Dichtschnur”) into the sealing groove only on the front side of the rear section. Start at the top and press lightly to adhere to the Primer 181 (Fig. 11).
- Unroll sealing cord and remove paper backing during installation. Cut sealing cord to length with a pair of scissors or knife. Butt sealing cord ends tightly together or overlap cord ends 1” for proper sealing.
- Clean a set of push nipples with a rag soaked in thinner. Wipe dry. A set consists of the 4 3/4” x 2” top nipple and the 2 1/4” x 2” bottom nipple.
- Evenly coat slightly over half the width of the outer surface of each push nipple with the orange sealing compound.
- Insert the coated side of the nipples into the ports.
- Set nipples in place by tapping evenly with a rubber or wooden mallet. Make sure the nipples remain perfectly aligned with the boiler section (Fig. 12).

NOTE: *If a burr on the push nipple occurred during nipple insertion, file it off immediately!*

- Finish coating the outer surface of the push nipples with orange sealing compound.
- Clean and coat nipple ports of intermediate section with orange sealing compound. Also clean flueway sealing grooves.

This completes the preparation of the joint between the rear section and the first intermediate section.

Check: 1. Both push nipples installed evenly with the rear section and nipples and ports fully coated with orange sealing compound.
2. Sealing cord is properly installed in all sealing grooves.

- Position intermediate section in front of rear section and hang from upper push nipple. It may be necessary to lift up the intermediate section at the bottom with a bar. Arrow markings must point to the rear.
- After aligning ports with push nipples, tap against the intermediate section with the mallet to seat it on the push nipple.

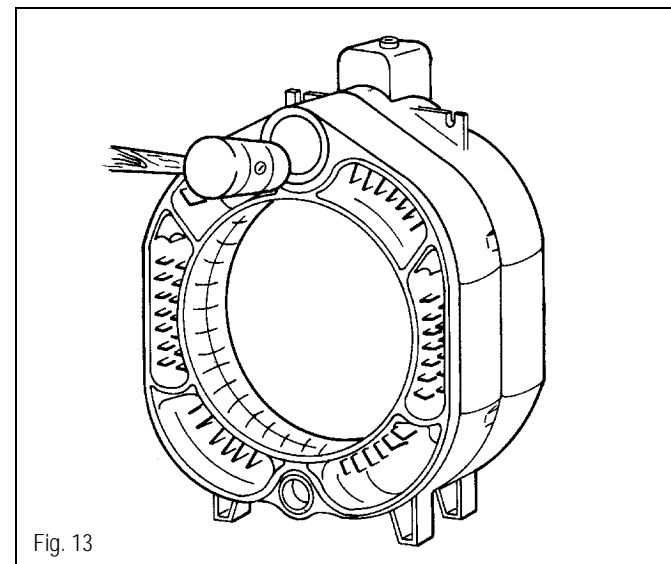
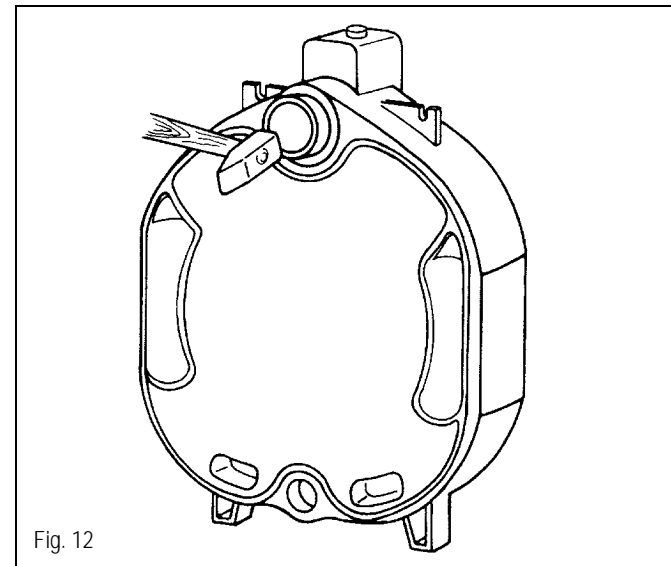
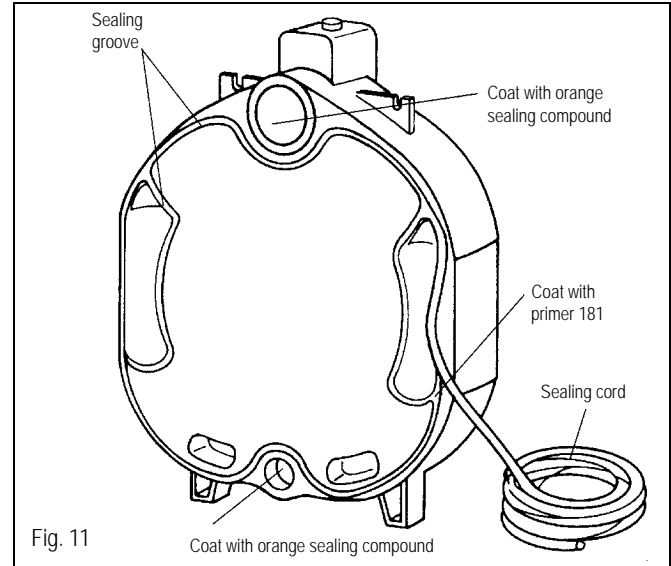

Pull sections together with boiler assembly tool

- Place assembly rods through upper and lower ports as shown (Fig. 14).
- Slide small pressure flange on each end of the lower assembly rod.
- Thread the pressure flanges on the rods.
- Slide stop flange on upper rod, insert straight pins on both rods.
- Lock flanges on assembly rods with straight pins in place by hand tightening assembly tools.
- Ensure that the tools are centered in the ports by having flanges properly located.
- Use socket wrenches provided to draw sections together evenly. Stop tightening when boiler sections abut metal to metal. Unscrew assembly tools.

NOTE: Inspect seating to ensure nipples are seated square. Never draw more than one section at a time to avoid damage to the push nipples and ports.

- Repeat boiler assembly procedure for subsequent sections as detailed on pages 9-11.

NOTE: After the boiler block has been drawn together, loosen the tools, but do not remove.

- Install tie bars in the cast iron slots on the left and right sides of the upper and lower nipple ports (Fig. 15).
- Slide one spring assembly on each tie bar at the rear section. Do not disassemble the spring assemblies! Place a washer and nut at both ends of each tie bar. Install a second nut on each tie bar at the front of the boiler.
- Hand tighten each nut first; then tighten the tie bar nuts on one end by 1 to 1½ turns with a wrench.
- Level the boiler horizontally and vertically. **Now**, remove the assembly tools.

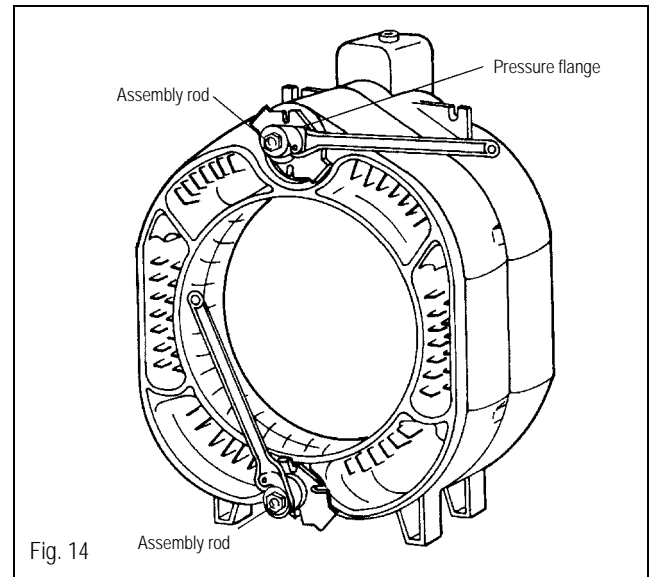

Fig. 14

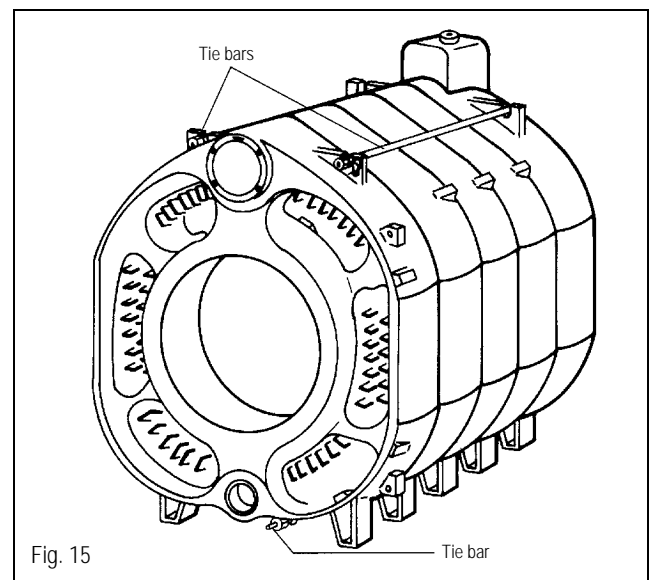

Fig. 15

7 Hydrostatic Test

Hydrostatic Test

Preparing for the hydrostatic test

- A pop-off relief valve is recommended on cold water feed line to prevent over pressurization.
- Install return header pipe per instructions on page 13.
- Seal the front ports with blank flanges and gaskets.
- Install return header or flange on the lower tapping with gasket provided (Fig. 16).
- Install supply header at the top tapping of the rear section. See Chapter 10, page 20 for details. Install a temporary air vent (not provided) in one tapping.
- Cap off return and supply headers. (Blank flanges, gaskets or plugs not provided).
- Install fill/drain valve at the lower rear connection (Fig. 16).
- Install long shank well into 3/4" tapping of rear section.
- Fill the boiler. Vent the boiler at the air vent until water appears. Close the vent and pressurize the boiler.
- The assembled boiler shall be subjected to a hydrostatic test pressure not less than 1^{1/2} times the maximum allowable working pressure. The maximum test pressure shall not exceed the required test pressure by more than 10 psi.
- If a nipple port connection is leaking, bleed off test pressure, drain water through the fill/drain valve, remove the four tie and the return header pipe rods.
- Split the boiler at the leaking joint by driving chisels at the top and bottom between the sections (Fig. 17).
- Remove old nipples and clean ports as shown on page 9. Reinstall flue sealing material. Material can be reused. Reassemble per instructions on pages 10-12.

NOTE: *Always use new push nipples when reassembling the boiler*

- Repeat the hydrostatic test to ensure no leaks.
- Install relief valve after the hydrostatic test.

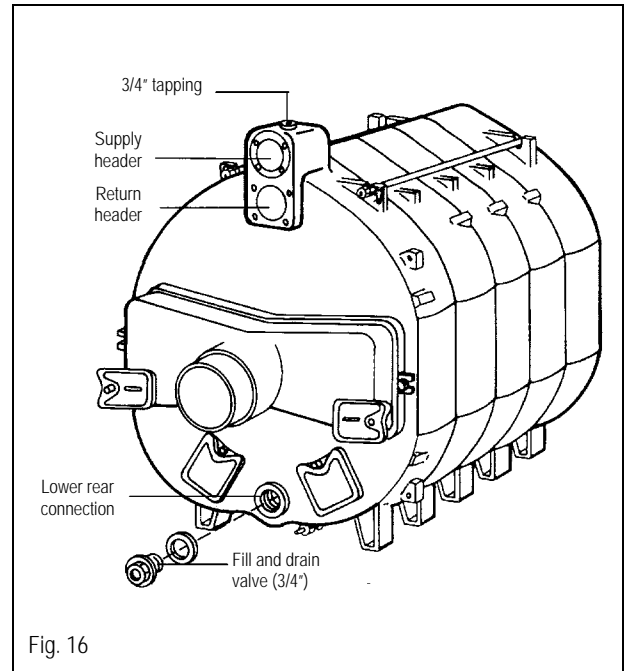

Fig. 16

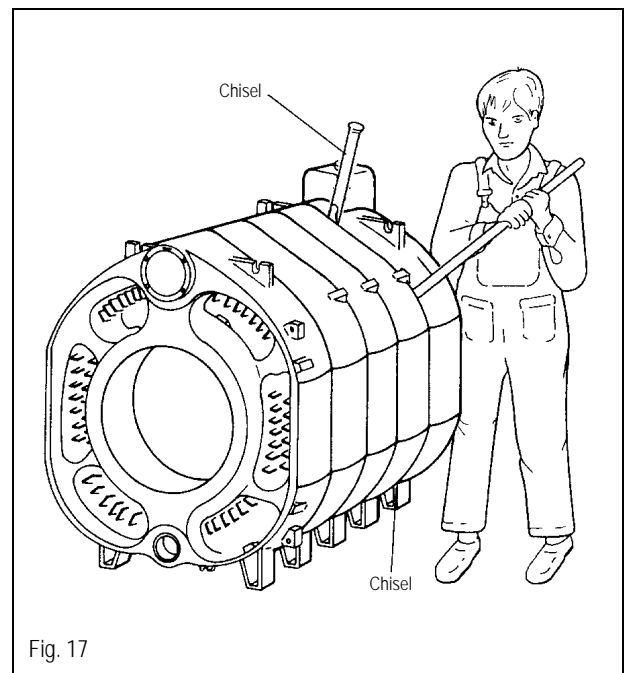
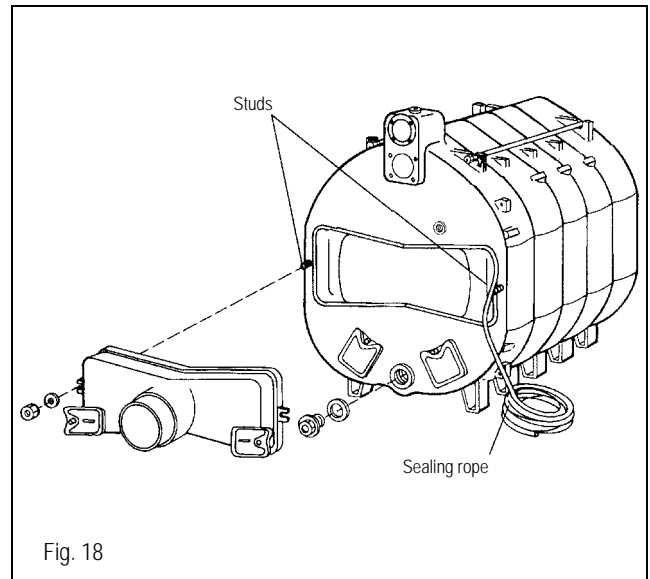

Fig. 17

Flue gas collector installation

- Install the pliable sealing rope in the groove of the rear section.
- Place the flue gas collector on the studs and tighten with washers and nuts provided to ensure a gas tight seal (Fig. 18).



Installation of rear section clean out covers

- Install sealing ropes into grooves around cleaning covers.
- Place cleaning cover on studs provided (Fig. 19). Secure with washers and nuts provided to ensure a gas tight seal.

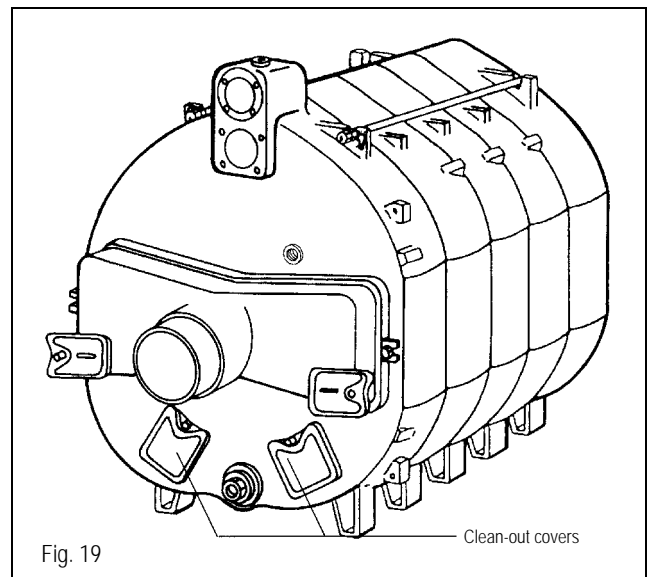

Installation of return header pipe

- Place gasket over return header pipe (Fig. 20).
- Insert the return header pipe into upper port from the front of the boiler (Fig. 20).
- The tab on the header pipe must be aligned with the recess in the front boiler section. This locks the header pipe into proper position and ensures that the outlet openings are positioned correctly to provide optimum water distribution.
- Install blank flange on studs and secure with nuts and washers.

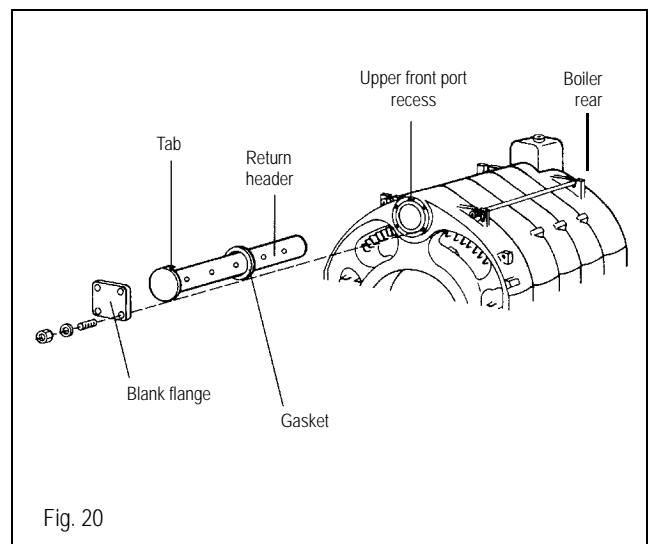

8 Installation of Boiler Components

Flue gas baffle plates

- Flue gas baffle plates are factory installed in an assembled boiler. Remove corrugated card board from baffle plates and insert plates as shown in Figure 21.

NOTE: Install the baffle plates per schedule below.

Table 6: Baffle Plate Arrangement

No. of Sections	Number of Baffles	Length (in)	Placement
5	4	14 ¹ / ₄ "	top & bottom (left & right)
6-7	4	17 ¹ / ₄ "	top & bottom (left & right)
8	4	14 ¹ / ₄ "	top & bottom (left & right)
9	4	8"	top & bottom (left & right)

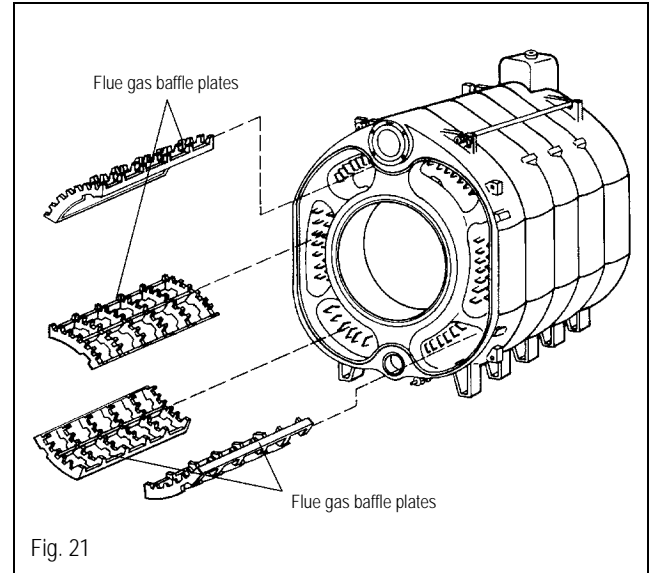

Fig. 21

Burner Door

- Attach sealing rope to front section by applying several drops of glue (P/N 422841) every 6" in the sealing grooves surrounding the combustion chamber and the outer area of the front section (Fig. 22).
- Insert the permanent pliable sealing rope in the grooves on the front section.
- The burner door hinge supports are factory installed on the right side. Remove and mount them on the opposite side with (2) M12x35 bolts for a left hanging door if required.
- Secure the door hinges, if required, with (2) M12x35 bolts to the proper side of boiler front section (Fig. 22).
- Hang the burner door on the door hinges.

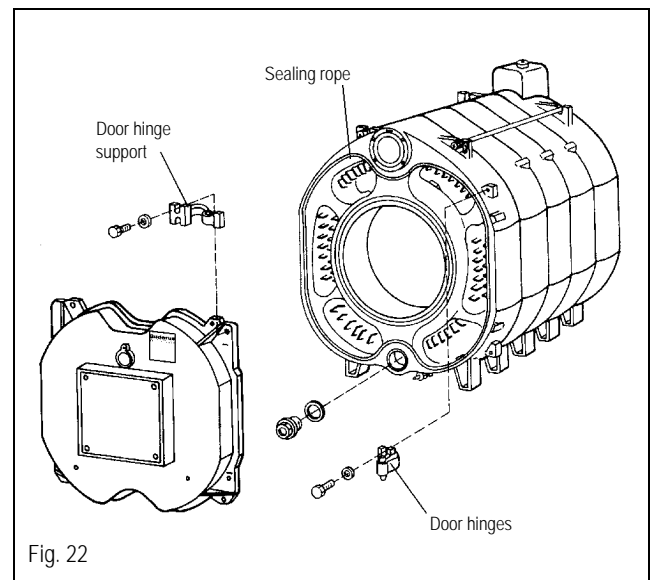
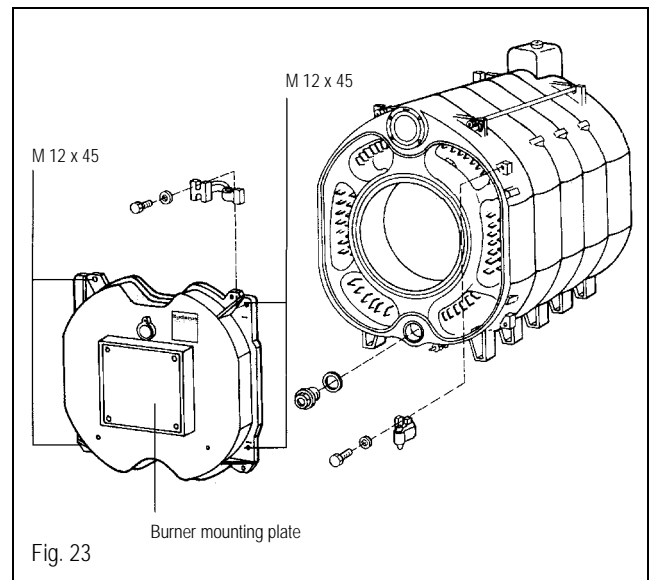

Fig. 22

- Hang and close burner door and **tighten evenly** with the (4) M12x45 burner door bolts (Fig. 23).
- Cut and drill the burner mounting plate according to burner specifications. (The burner plate can be cut by Buderus Hydronic Systems per specifications submitted with the boiler order).
- Mount burner mounting plate to burner door. Seal with 1/2" diameter sealing rope.
- Cut burner door insulation material to conform to burner tube diameter.
- Mount burner per burner manufacturers instructions.



Fill burner door with insulation per instructions below.

- Cover burner tube and sight glass port with paper to prevent filling these areas.
- Mix insulating cement with water to pulp consistency.
- Fill any spaces between burner door insulation and burner tube with the insulating cement (Fig. 24).

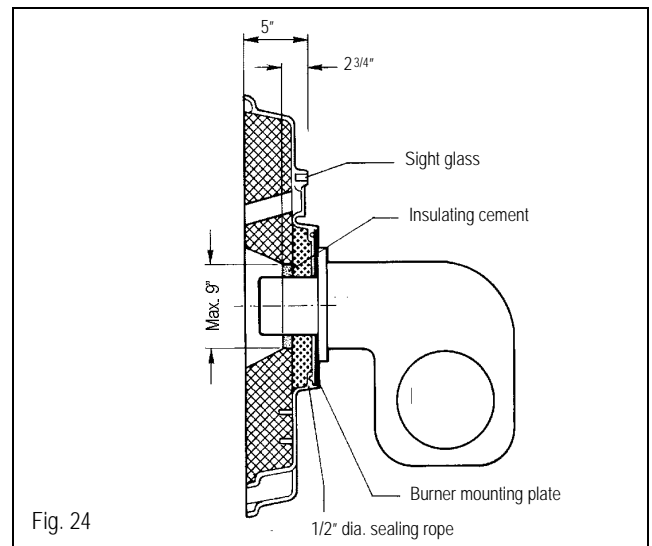

9 Installation of Insulation & Boiler Jacket Panels

Location of support brackets for jacket panels

- Loosen the first nut from the upper front tie bar.
- Position the upper front support bracket between the first and second nut. Point the folded edge of the bracket forward (Fig. 25).
- Place the rear support bracket on the back section and secure with M8x15 bolts. Point the folded edge of the bracket forward (Fig. 26).

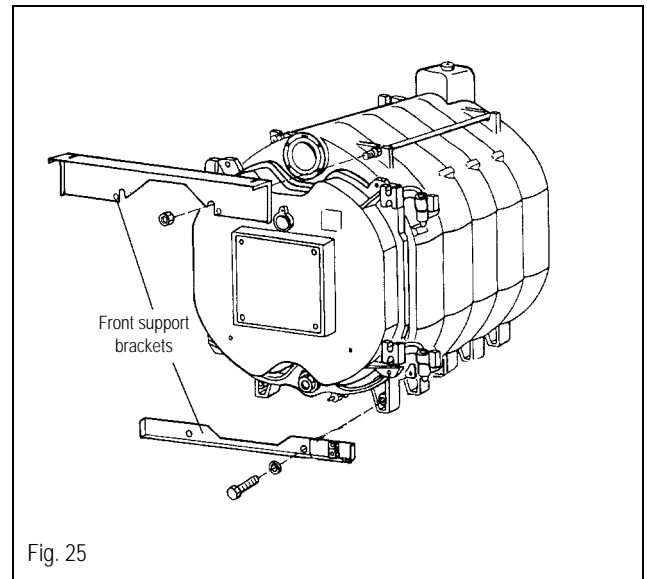

Insulation blanket

The insulation blanket consists of 1 piece with length "L" varying with boiler model.

No. of Sections	Length "L"
5	33
6	39 1/2
7	45 1/2
8	52
9	58 1/4

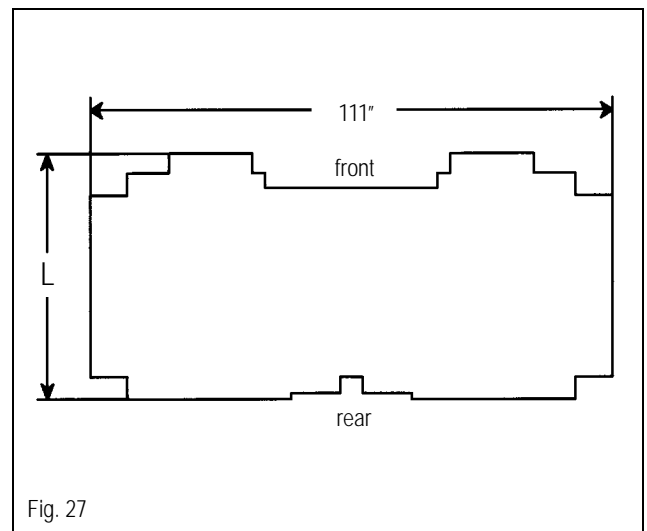
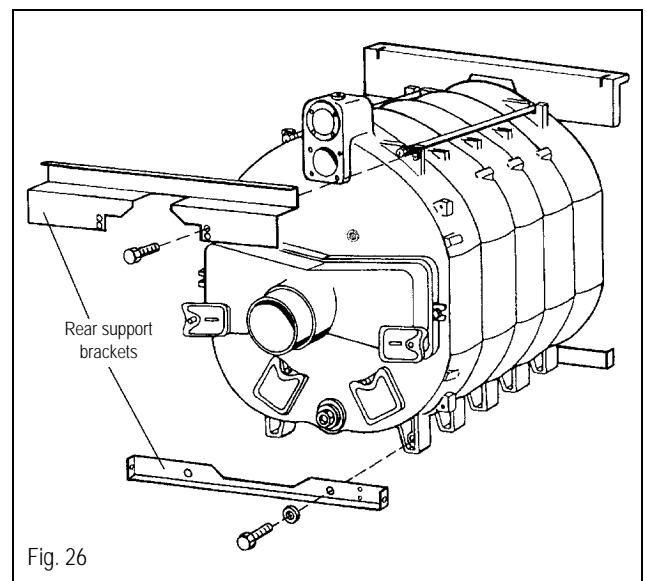

- Arrange the insulation blanket according to Figure 28.
- Push the insulation between the boiler feet. Cut-out provisions are made in the blanket for this purpose.
- Install the rear insulation piece with the return connection cut-out upward on the vent connection (Fig. 28).
- Secure the rear insulation piece with two tension springs to the upper support bracket.
- Close the slit in the rear insulation below the vent connection with a tension spring.
- Slide the insulation piece with cut-out onto the folded edge of the front upper support bracket (Fig. 29).

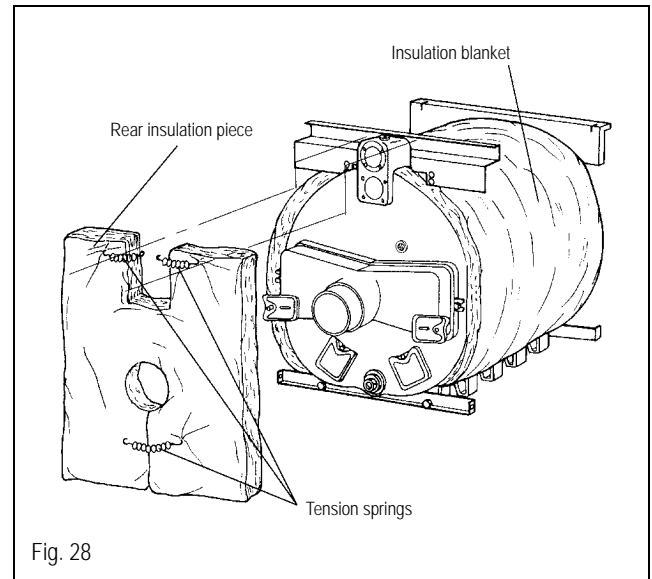

Fig. 28

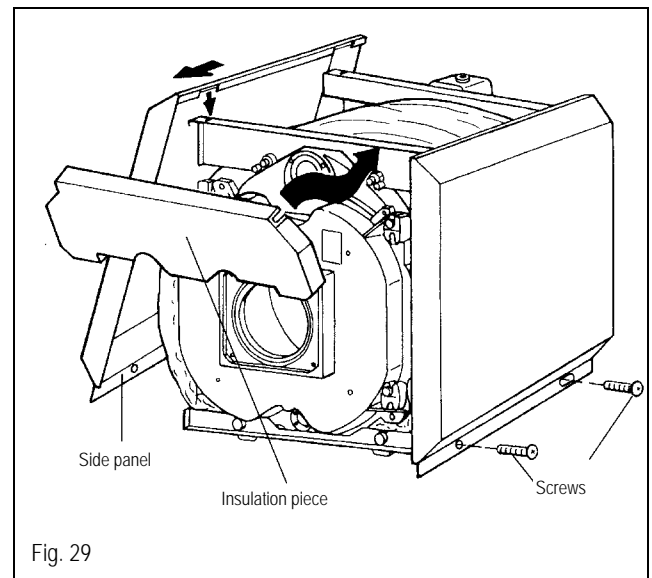

Fig. 29

Installation of boiler jacket panels.

- Hang the side panels at the knock-outs on the support brackets and slide them forward until fully engaged with the support bracket slots (Fig. 29).
- Secure the bottom of the side panels to the lower support brackets with two sheet metal screws (Fig. 29).
- Place the front top cover between the side panels with its knock-out aligned with the support bracket (Fig. 30).
- Secure the front top cover on the back side with two screws to the side panels (Fig. 30).

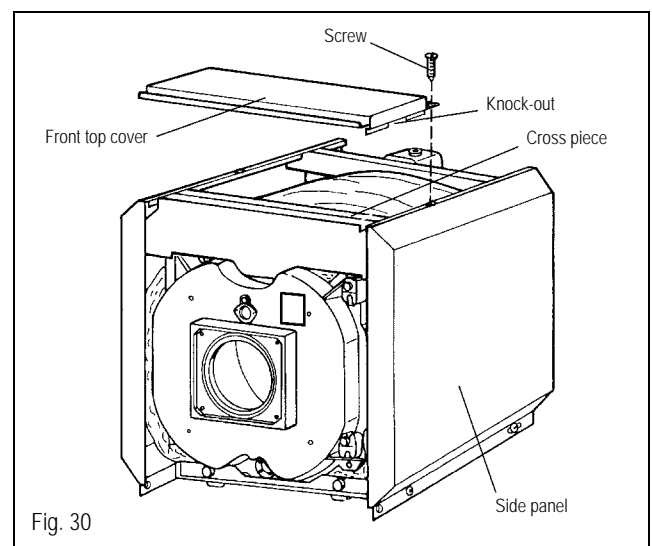
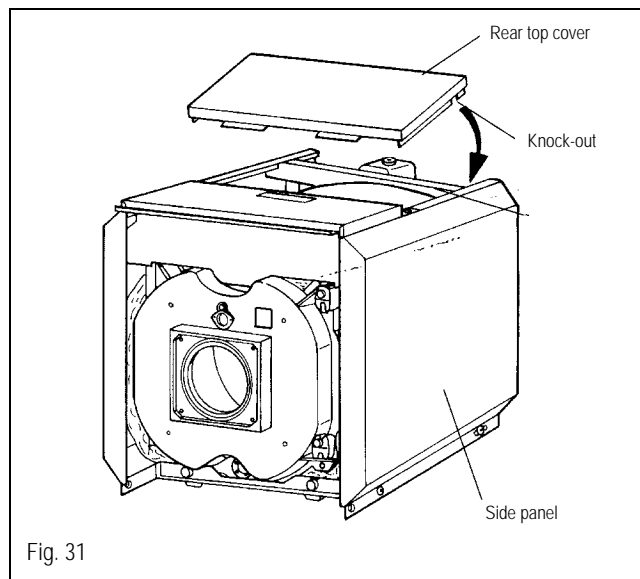

Fig. 30

9 Installation of Insulation & Boiler Jacket Panels

- Place the rear top cover between the side panels with its knock-outs aligned with the support bracket (Fig. 31).

NOTE: In case a Buderus Ecomatic control is used, install the sensors and capillaries in the appropriate wells before all top jacket panels are in place.



- Slide the lower front cover on the lower portion of the side panels and secure with sheet metal screws (Fig. 32).

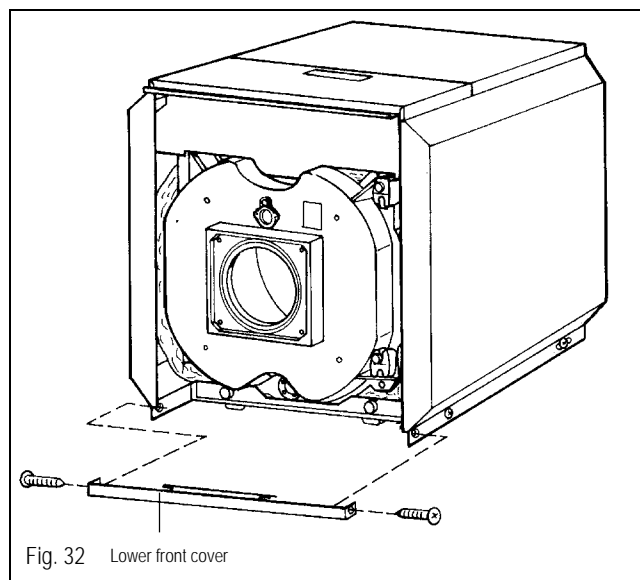

- Secure the upper rear cover with screws to the side panels and rear top cover (Fig. 33).

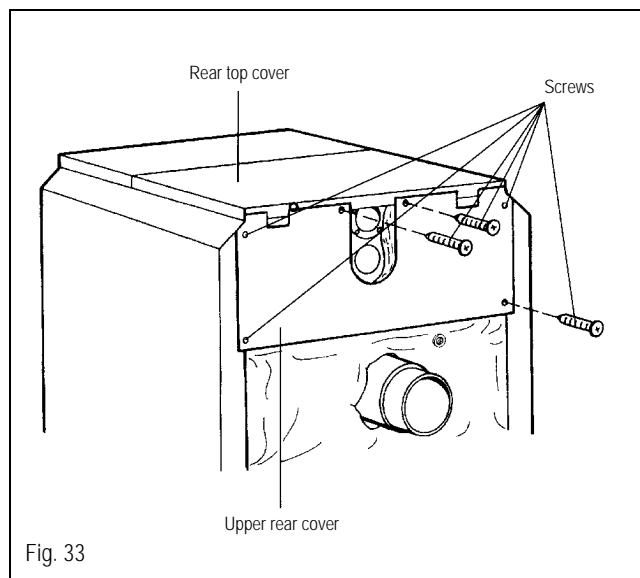

- Secure the lower rear panel with the knock-out for the drain on the bottom with screws to the side panels (Fig. 34).

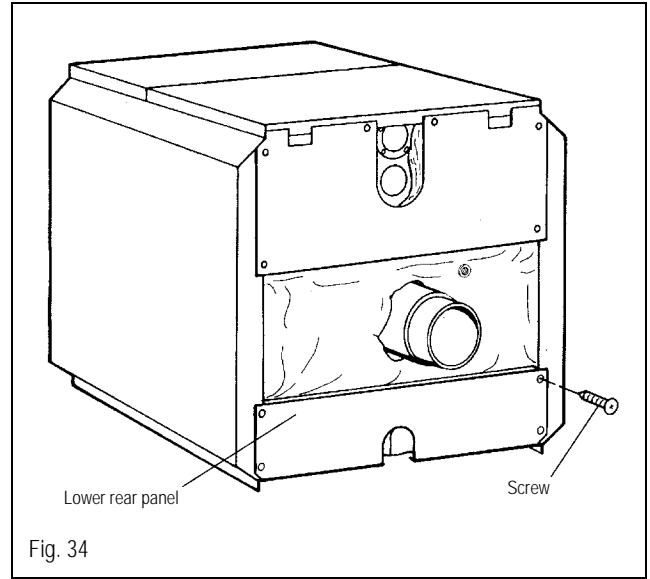

- Snap the bottom of the front panel in the lower front cover and support it at the top from the folded edge (Fig. 35).

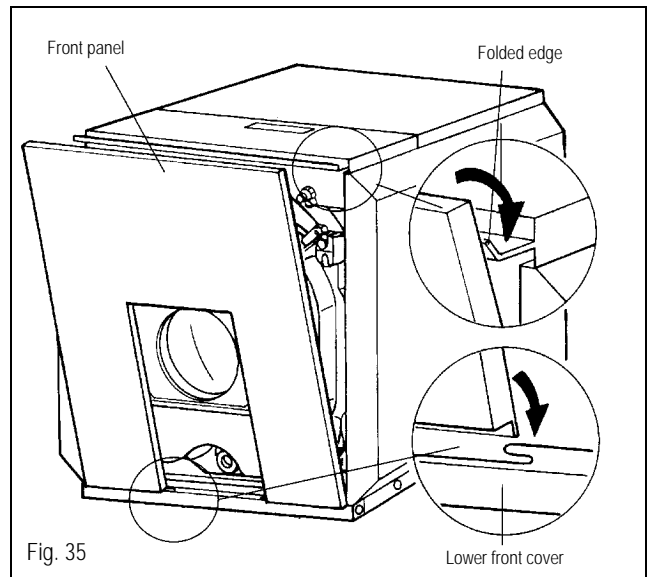

- Hang the burner door cover into the knock-outs of the front panel (Fig. 36).
- Secure second rating plate to the side panel for best viewing.

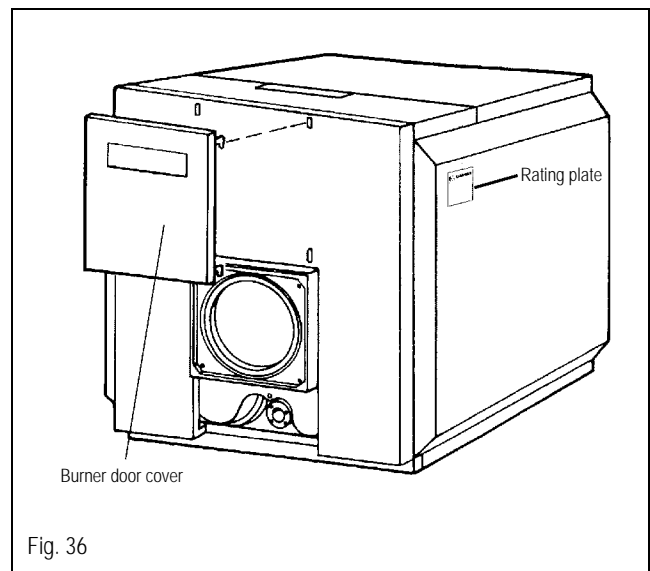

10 Installation of Hydronic Control Components

Installation of supply header and controls

NOTE: The G315 boiler can be equipped with 2" or 3" supply/return connections depending on items ordered. The 3" supply manifold is suitable for commercial installations.

- Refer to Figure 37 for details on the 3" supply header for use in commercial installations requiring multiple aquastats.
- Secure supply manifold with supplied nuts and gasket to supply connection in desired orientation.
- Secure return flange/manifold with gasket to return connection.
- Install low water cut-off probe and P&T gauge in appropriate tapings (3" header only).
- * Install relief valve after performing the hydrostatic test.
- Pipe the relief valve discharge to a floor drain in accordance with local code requirements.
- Install required number of 3/4" immersion wells in 3" supply header tapings.

NOTE: If a Buderus Ecomatic is used, install the Ecomatic well and the Ecomatic sensors in the rear boiler tapping.

- Install the L8148A aquastat in rear boiler tapping.
- Install the supply temperature control aquastat (if required) in a 3/4" tapping.
- For commercial installations, install the L4006E1109 manual reset in the rear boiler tapping.
- Install L4006A1058 operating aquastat in another 3/4" immersion well of 3" the supply manifold. (Install second L4006A1058 aquastat for Low/Hi/Low burner operation).
- Plug all unused tapings.

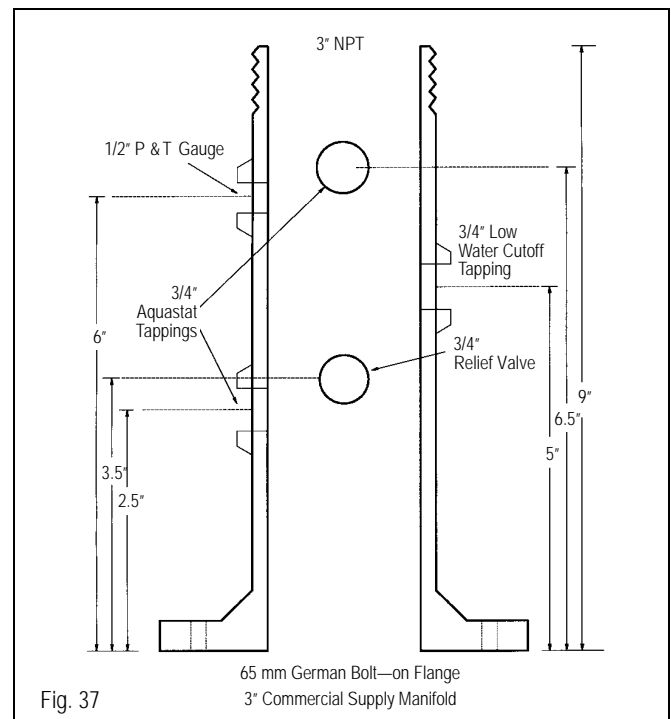

Maintenance of boiler

Check burner operation on a regular basis. Verify efficiency of boiler and ensure soot free operation. Inspect flue way passages.

Clean boiler annually.

Cleaning brushes are available from Buderus Hydronic Systems.

Boiler cleaning with brushes

- Disconnect electricity. (Disconnect main system switch and padlock open to prevent the burner from being energized during service).
- Disconnect fuel supply and electrical wires to the burner.
- Slightly pick up the front panel and tilt backwards for removal.
- Remove the four bolts from the burner door.
- Swing open burner door.

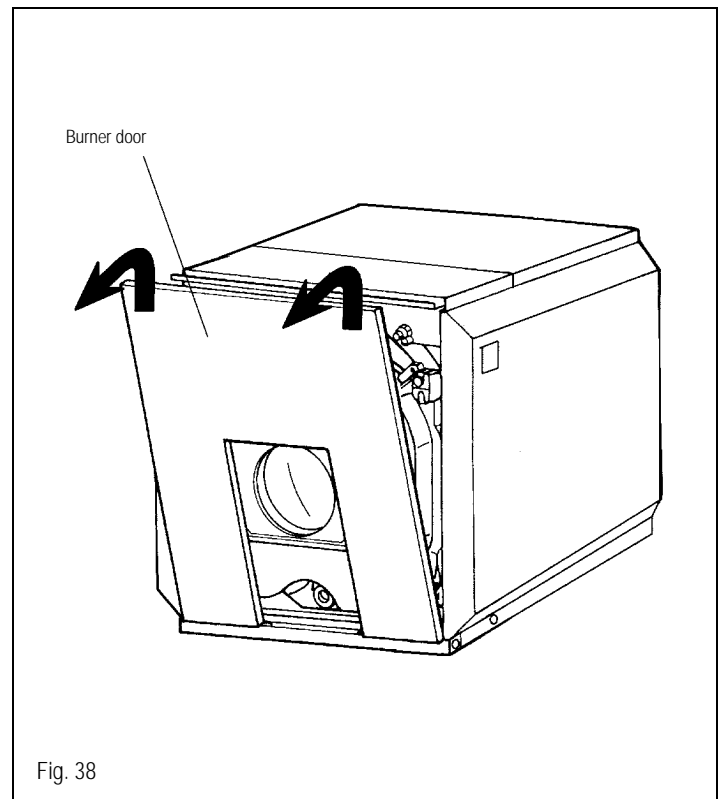

11 Maintenance Instructions

- Remove flue gas baffle plates from secondary heat exchanger from the front (Fig. 39).

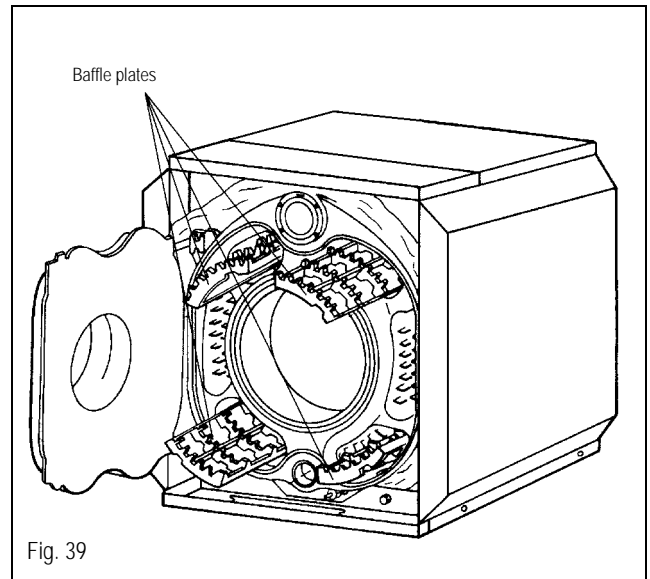

- Remove the screws from the lower rear panel at the lower back of the boiler. Remove this panel (Fig. 40).
- Remove tension spring assembly below vent connection, lift the insulation upward to expose clean-out cover, and fasten with springs as shown (Fig. 40).
- Remove clean-out covers from back section and flue gas collector.

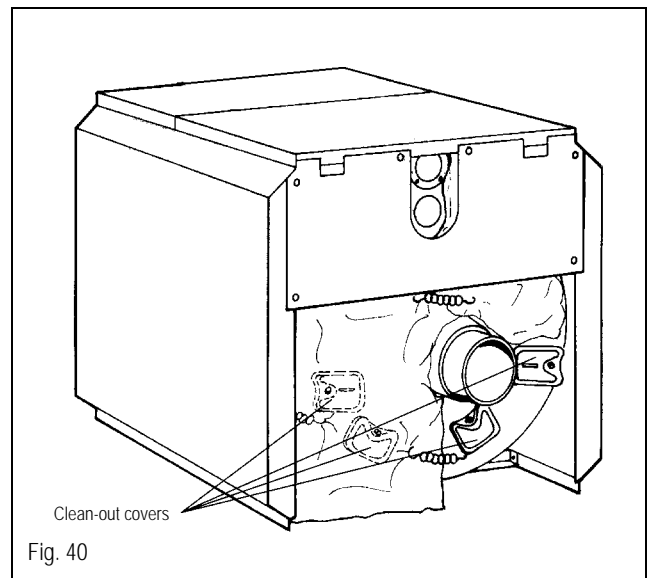

- The required brushes necessary for cleaning are as shown (Fig. 41).

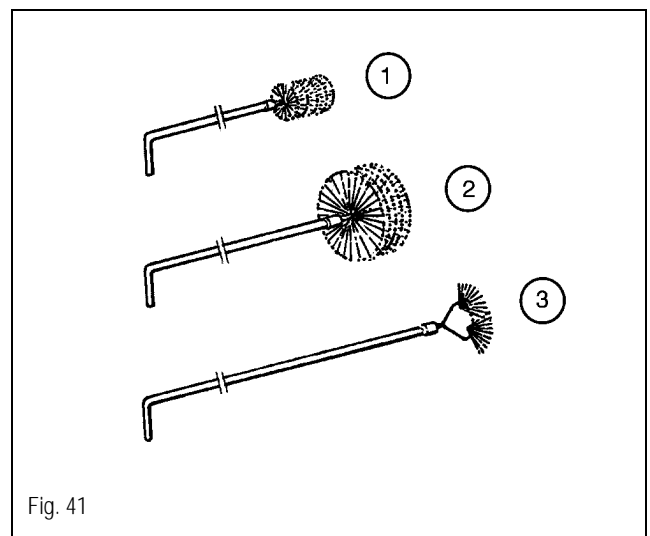

- Brush top secondary heat exchanger passages with brushes #1 and #2 (Fig. 41 and 42).
- Clean the rear wall of the combustion chamber with brush #3.
- Clean sides of combustion chamber with brush #2.
- Remove deposits and soot from flue collector (Fig. 43).
- Brush the lower flue passages from the front and rear with brush #2 (Fig. 42).
- Remove all deposits and soot from combustion chamber and passages.
- Check integrity of sealing ropes of clean-out covers and burner door. Replace sealing ropes if damaged or hardened by contacting Buderus Hydronic Systems.
- Insert flue gas baffles. See page 14 for details.
- Reinstall clean-out covers and secure burner door. Tighten bolts and screws evenly. Reinstall back jacket panel.

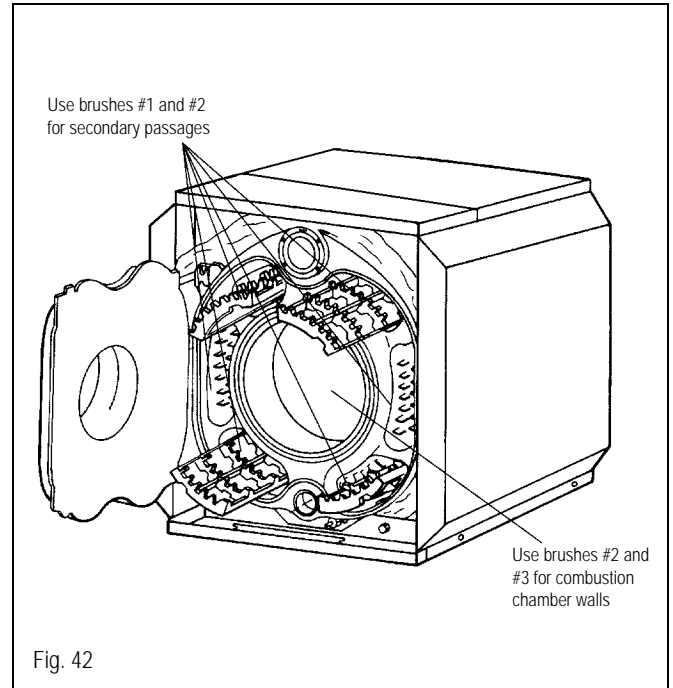

Wet cleaning procedure

- Follow the above procedure for accessing the boiler to perform a wet cleaning of the boiler. Follow cleaning agent instructions.

Water level control

- Maintain water pressure within the required levels.
- Verify system water level; add water and vent as needed. Automatically add water to system and vent during operation. Determine and correct problem if continuous make-up water must be added to the system.

Note: Continuous make-up water indicates a leak in the system. This causes corrosive damage to all system components and must be solved immediately.

Warranty voided if problem is not corrected.

Fill and make-up water requirements

- Fill and make-up water must comply with the requirements listed on page 4.

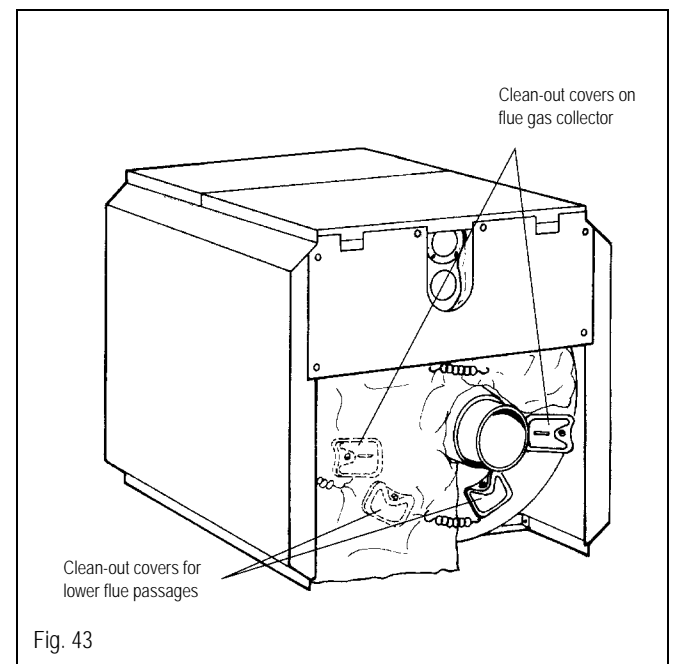

12 Optional Noise Reduction Equipment

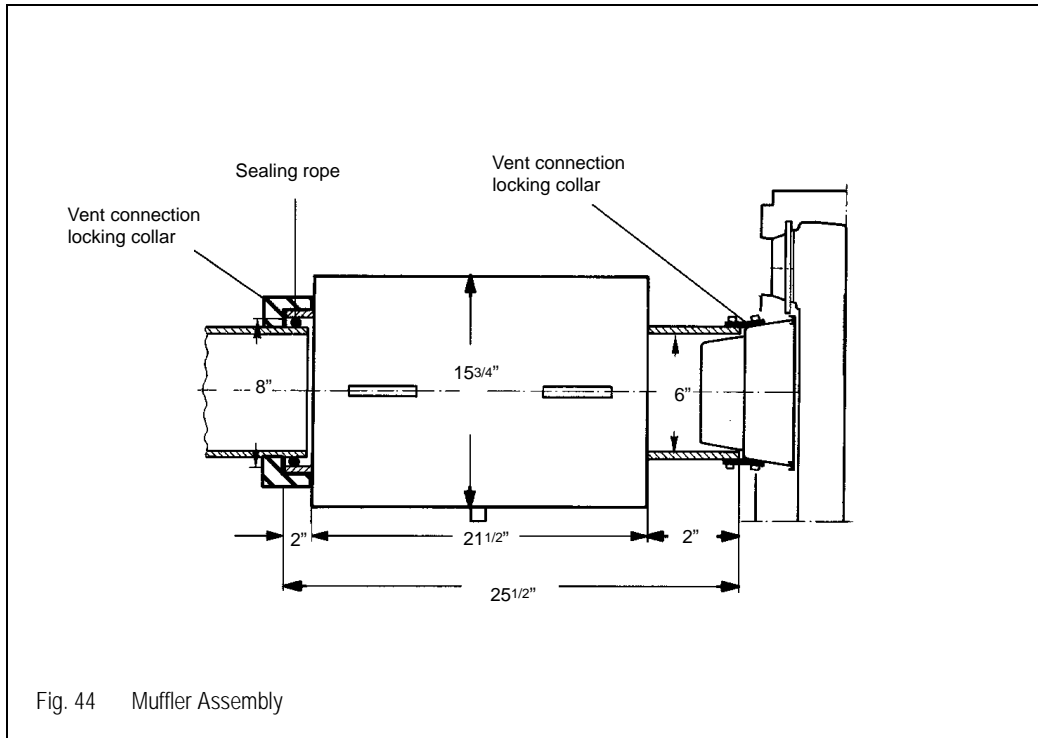

Components not in stock. Allow 4-6 weeks for delivery.

Table 6. Shipping Component Reference Table

Boiler Sections part no.	G315/5 5029530	G315/6 5029540	G315/7 5029550	G315/8 5029560	G315/9 5029570
Front and rear section, 3 intermediate sections, burner door part no. 5621512	1	1	1	1	1
Additional intermediate section/s part no. 5479400		1	2	3	4
Boiler jacket	5614602	5614604	5614606	5614608	5614609
Insulation	5614672	5614674	5614676	5614678	5614680
Accessory box	5620700	5620702	5620704	5620706	5620708
Tie bars	5127882	5127884	5127886	5127888	5127890
Return pipe	5436502	5436504	5436506	5436508	5436510

Brief description of individual shipping components

Skid 1: Front, rear sections, 3 mid-sections and burner door.

Skid 2: Required number of mid-sections.

Boiler Jacket: Hardware components for boiler jacket installation.

Insulation: Bag with wrap-around insulation.

Accessory box: All hardware components needed to assemble the boiler. Boiler blanking flanges and gaskets are found here.

Tie bars: Bundle of threaded rods to hold sections together.

Return pipe: Return header pipe.

Header and control box: Supply and return headers with optionally ordered control components.

14 Supply Temperature Control

Supply temperature control

An “Open-On-Rise” aquastat is required to interrupt water circulation through the boiler to prevent the supply temperature from dropping below 122°F during burner operation. The aquastat is to temporarily stop operation of the main system pump (or individual boiler pumps in case of a multiple boiler installation).

Refer to Figure 45 for a typical control schematic for a single boiler with supply temperature control. Control components can be furnished by Buderus Hydronic Systems, Inc.; relay, burner and circulator operating controls can not be provided.

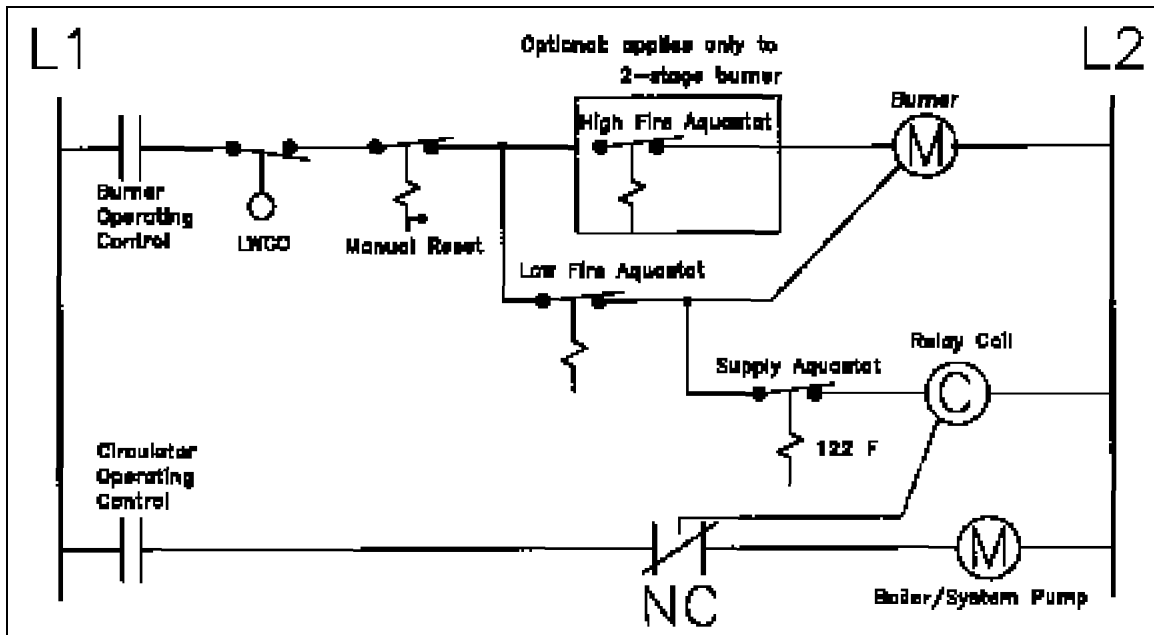

Fig. 45 Typical Control Schematic

Notes

Notes

Boiler installed by:
(contractor's address)

Boiler installed on:
(date of installation)

Buderus
HYDRONIC SYSTEMS

Buderus Hydronic Systems
50 Wentworth Avenue
Londonderry, NH 03053 USA
Tel: (603) 552-1100 • Fax: (603) 421-2719
www.buderus.net

Buderus Hydronic Systems, Inc. reserves the right to make changes without notice due to continuing engineering and technological advances.