

Assembly, Maintenance and Operating Instructions

Buderus G515 Boiler



Save These Instructions !

This assembly, maintenance and operating manual must be kept near the boiler !

TABLE OF CONTENTS

1	General Guidelines	3
2	Boiler Operating Data	4
3	Technical Data	5
4	Boiler Foundation and Minimum Boiler Clearances	6
5	Assembly Tools/Tools Req'd for Boiler Assembly	7
6	Boiler Assembly	8-11
7	Hydrostatic Test	12
8	Installation of Boiler Components	13-15
9	Installation of Insulation & Boiler Jacket Panels	16-22
10	Installation of Hydronic Control Components	23
11	Maintenance Instructions	24-26
12	Increasing the Stack Temperature	27
13	Optional Noise Reduction Equipment	28
14	Shipping Component Listing	29
15	Supply Temperature Control	30

General guidelines

Installation, maintenance and service of this boiler must only be carried out by a qualified contractor. The assembly sequence is essential to reliable operation of the boiler and associated heating system. The boiler can be assembled, hydrostatically tested and operated without boiler insulation and jacket panels. These items can be installed at a later date without disrupting boiler operation.

NOTE: A minimum **supply** temperature of 122° F must be maintained during burner operation. Controls must be provided that will shut off circulation through the boiler when the **supply** temperature drops below 122° F. This requirement applies only during burner operation. There is no minimum return water temperature requirement.

All work shall be performed in strict accordance with the requirements of state and local regulating agencies and codes dealing with boiler installations. Initial start-up must be performed by qualified personnel. After start-up the owner or its representative should be instructed about the boiler operation and be given the assembly and maintenance manual.

Boiler cleaning and maintenance must be carried out once annually. This includes an overall check of the heating system. Any discrepancies must be corrected immediately.

NOTE: To perform the hydrostatic pressure test after the boiler is assembled, 2-125 lbs. 4" blanking flanges, 3/4" and 1" plugs and a 3/4" air vent may be needed. These items are *not* furnished with the boiler.

NOTE: This manual is for reference only. The manual does NOT purport to address all design, installation and safety considerations. It is the responsibility of the user of this manual to determine the applicability and safety of each individual application and ensure its compliance with local building codes.

It is expected that the user/installer is a licensed heating contractor with knowledge of accepted industry practices for the installation and maintenance of the equipment and various applications of the equipment involved.

2 Operating Data

Boiler operating ratings

Maximum supply temperature: 248°F (120°F)
Maximum operating pressure: 58 psi (4 bar)

Water quality requirements

Fill water requirement: water with alkalinity < 200 mg/li for initial system filling.

Make-up water requirement: water with alkalinity < 30 mg/li

System water requirements:

pH value (@ 77°F):	9.0 - 10.0
Acid capacity:	3.0 - 50 mg/li
Oxygen (O ₂):	.01%
Phosphate (P ₂₀₅):	2.5 %
Sodium sulfate (Na ₂ SO ₃):	1 - 4%

For overall system protection, it is recommended to install a filter and sludge removal system in the boiler return piping.

Any approved (based on application testing at burner manufacturer's facilities) oil or power gas burner can fire into G515 boilers. Burners with low fire start or two stage firing are recommended. The high fire setting on the burner should match the rated output of the boiler to prevent condensation in the heat exchanger. The CO volume percent in undiluted, dry flue gas should not exceed .04% (400 ppm).

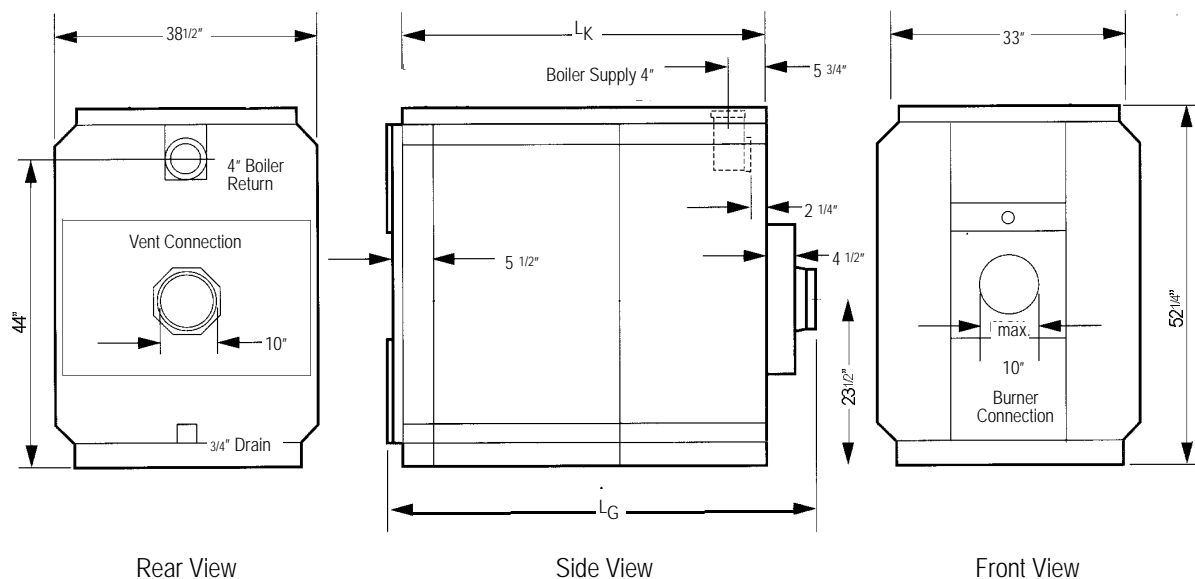

Table 1: Boiler Dimensions

Gross Output	Mbtu/h	818	1009	1200	1391	1582	1773
No. of Sections		7	8	9	10	11	12
Overall Boiler Length (L _G)	In.	62 1/4	69	75 3/4	82 1/2	89 1/4	95 3/4
Boiler Block Length (L _K)	In.	54 1/2	61	67 1/2	74 1/4	81	87 1/2
Minimum Boiler Width	In.	33	33	33	33	33	33
Fire Box Depth	In.	45 3/4	52 1/2	59 1/4	66	72 1/2	79 1/4
Fire Box Diameter	In.	20 1/4	20 1/4	20 1/4	20 1/4	20 1/4	20 1/4
Fire Box Volume	cu. ft.	14.87	17.16	19.46	21.75	24.05	26.31
Dry Weight	Lbs.	2731	3059	3505	3864	4188	4541
Water Content	Gal.	68.2	77.7	87.2	96.7	106.2	115.7
Operating Weight	Lbs.	3300	3707	4233	4671	5074	5506
Vent Connection Size	In.	10	10	10	10	10	10
Door Thickness	In.	5 1/2	5 1/2	5 1/2	5 1/2	5 1/2	5 1/2

Table 2: Technical Specifications

Gross Output	Mbtu/h	818	1009	1200	1391	1582	1773
No. of Sections		7	8	9	10	11	12
Boiler HP		24.5	30.2	35.9	41.6	47.3	53.0
NET IBR Rating	Mbtu/h	711	877	1043	1210	1376	1542
Max Input Oil	GPH	6.9	8.4	10.0	11.6	13.0	14.6
Max Input Gas	Mbtu/h	995	1216	1438	1660	1881	2103
Fire side heating surface	sq. ft.	113.9	132.0	150.3	168.5	186.7	204.8
Combustion efficiency	Oil %	88.2	88.2	88.1	88.1	88.1	88.1
Combustion efficiency	Gas %	85.6	85.5	85.5	85.5	85.4	85.4
Gross stack temp	low fire °F	280	280	284	264	266	284
	high fire °F	327-361	322-361	322-351	315-340	318-342	327-345
Fire Box Pressure	In. WC	.20-.24	.40-.57	.44-.65	.85-1.17	1.0-1.33	.97-1.25

4 Boiler Foundation and Minimum Boiler Clearances

Boiler foundation preparations

It is required that the boiler is placed on a level, smooth concrete base, of sufficient strength. The width of the platform must be $33\frac{1}{2}$ ". It is required to cement in either a $4"$ x $1\frac{1}{4}"$ flat steel plate or a $4"$ x $2"$ x $1\frac{1}{4}"$ angle iron, as shown in Figure 2; Table 3 shows dimensions.

Table 3: Foundation and support strip lengths

Model	B	L	C	F
515/7	$33\frac{1}{2}$	$53\frac{1}{2}$	$21\frac{1}{2}$	$46\frac{3}{4}$
515/8	$33\frac{1}{2}$	$60\frac{1}{4}$	$21\frac{1}{2}$	$53\frac{1}{2}$
515/9	$33\frac{1}{2}$	67	$21\frac{1}{2}$	$60\frac{1}{4}$
515/10	$33\frac{1}{2}$	$73\frac{1}{2}$	$21\frac{1}{2}$	67
515/11	$33\frac{1}{2}$	$80\frac{1}{4}$	$21\frac{1}{2}$	$73\frac{1}{2}$
515/12	$33\frac{1}{2}$	87	$21\frac{1}{2}$	$80\frac{1}{4}$

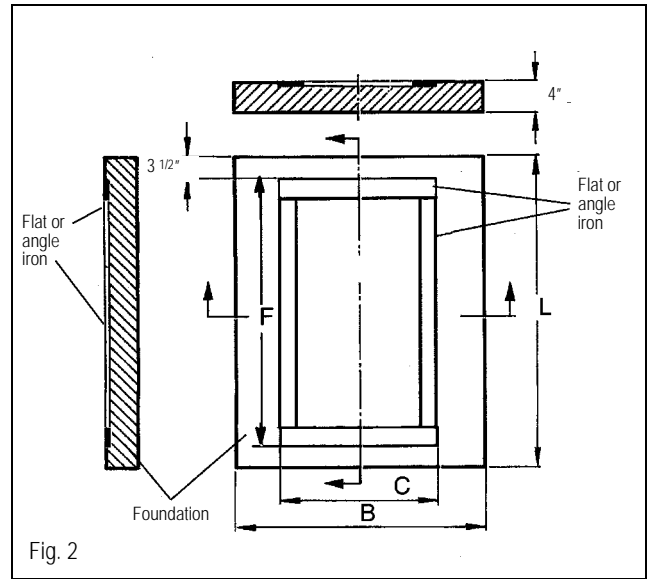

Minimum wall clearances

The recommended wall clearances must be observed in order to open the burner door, assemble the boiler and allow sufficient access for boiler maintenance. (See Figures 3 and 4 for details).

The burner door is field adjustable to hinge right or left.

Recommended clearances:

- Wall clearance W1: minimum 12".
- Wall clearance W2: Burner length A + 4", minimum 43".
- Wall clearance W3: Boiler length L + 40".
- Wall clearance W4: $\frac{1}{2}$ Boiler length + 20".

Absolute minimum clearances:

- Wall clearance W1: minimum 12".
- Wall clearance W2: Burner length A + 4", minimum 36".
- Wall clearance W3: Boiler length L or minimum 86".
- Wall clearance W4: 36".

Note: Wall clearance W3 can be reduced to 4 feet for assembled boilers. Boiler cleaning will now require use of segmented brushes.

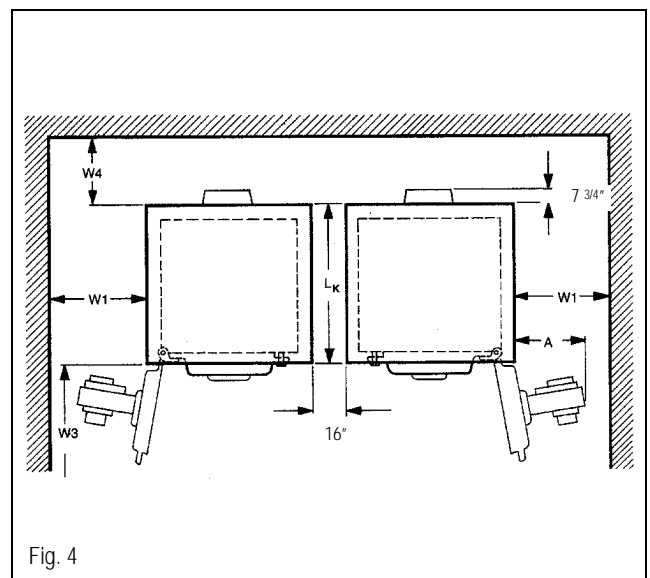
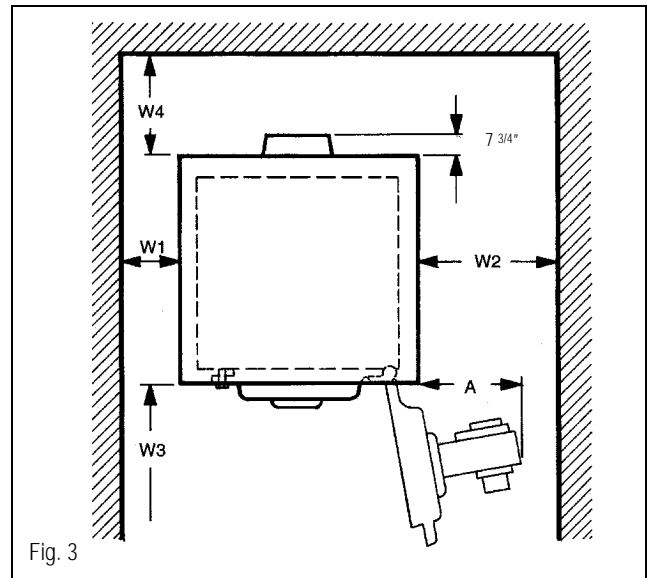

Assembly Tools/Tools Req'd for Boiler Assembly 5

Assembly tools and auxiliary assembly materials

- ✓ Boiler assembly tool rods size 2.2 (2 pieces)
- ✓ Wooden or rubber mallet
- ✓ Half-round rough file
- ✓ Flat head and Phillips screwdrivers
- ✓ Flat chisel, steel strips for boiler support
- ✓ Metric wrenches sizes 13, 19, 24, 36 and socket size 19 (US equivalent sizes may also be used)
- ✓ Cleaning rags, machine oil, gasoline or paint thinner, level, steel wire brush, tape measure,

chalk.

Boiler assembly tool components

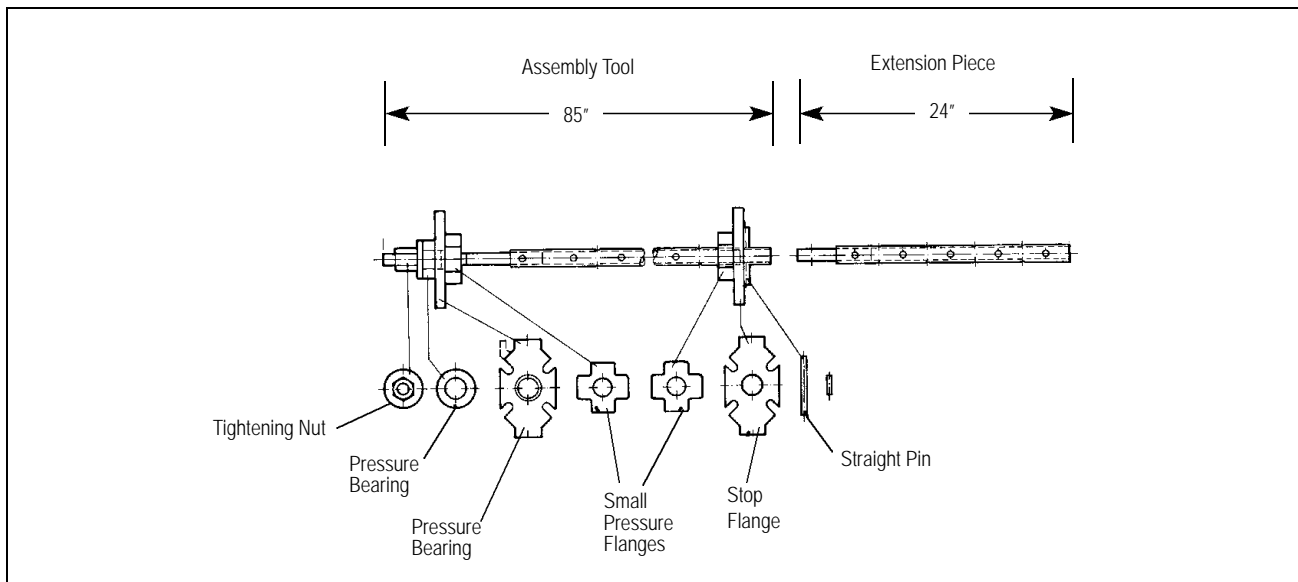

Table 4. Assembly tool requirements

No. of Sections	Assembly Tool	Extension Piece	Total tool Length (ft)
7-10	1	0	7
11-12	1	1	9

6 Boiler Assembly

Boiler block sectional arrangement

The boiler is always assembled starting with the rear section and finishing with the front section.

The arrow markings on the sections must point to the rear (Fig. 5) and use the sequence in Table 5.

Model	No. of Front Section	No. of Midsections	No. of Rear Section
515/7	1	5	1
515/8	1	6	1
515/9	1	7	1
515/10	1	8	1
515/11	1	9	1
515/12	1	10	1

Table 5: Boiler section arrangement

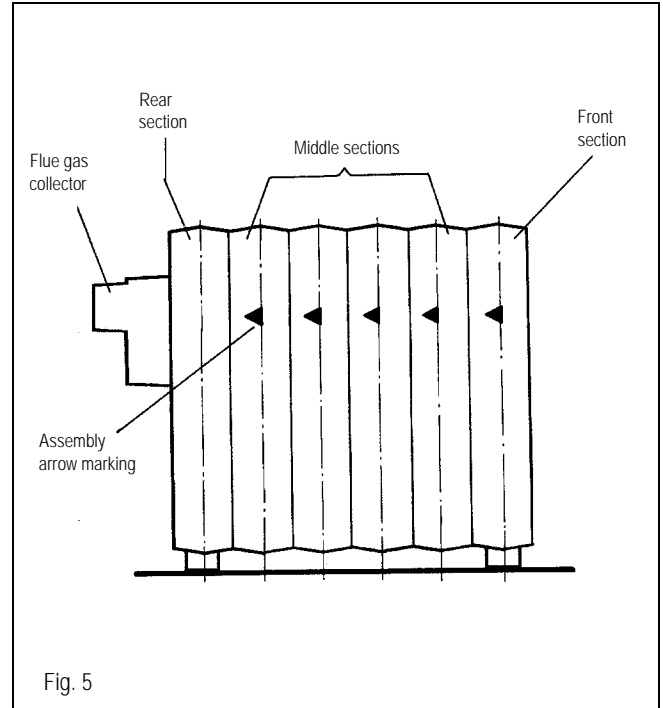

Fig. 5

Assembly of individual boiler sections

- Remove the nuts and washers from the rear and front sections prior to boiler assembly.
- Note the arrow marking on each section. These arrows are located on the top left and right of each section and must point to the rear during boiler assembly (Fig. 5).
- Assemble the boiler on a smooth hard surface with flat steel plates underneath to permit easy sliding of sections.
- Position and align the rear section upright in final location and secure it from falling over (Fig. 6).
- To reduce the risk of injuries, support the boiler section or secure it with an overhead lifting device.

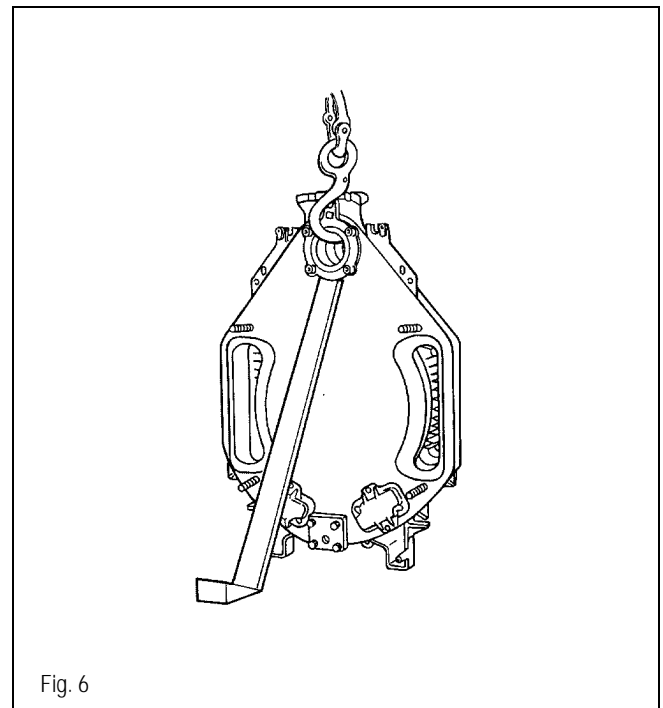
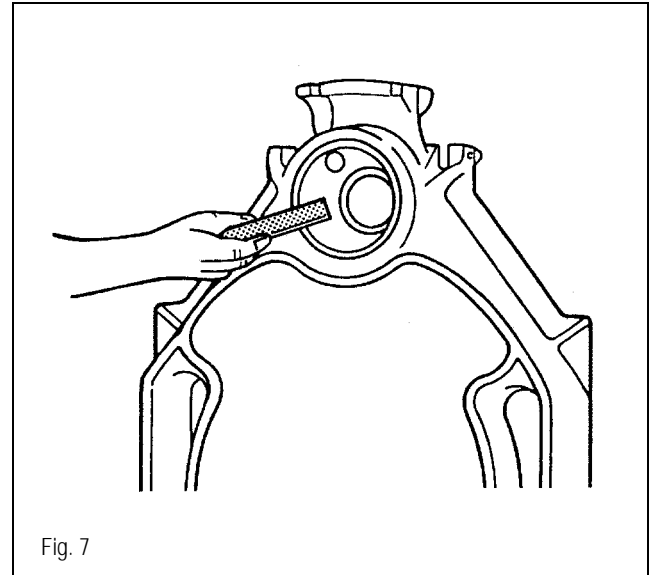

Fig. 6

CAUTION: The work area must be well ventilated during boiler assembly .

WARNING: Keep Haftgrund 181 away from flame ! Do not smoke during assembly ! *Do not* pour Haftgrund 181 down open drains !

- File off any burrs from the nipple ports (Fig. 7).



- Clean the sealing surfaces of the nipple ports with a rag soaked in thinner or gasoline. Wipe dry.
- Evenly coat the nipple port sealing surfaces with the orange sealing compound (Leinolmennige) using the brush provided (Fig. 8).

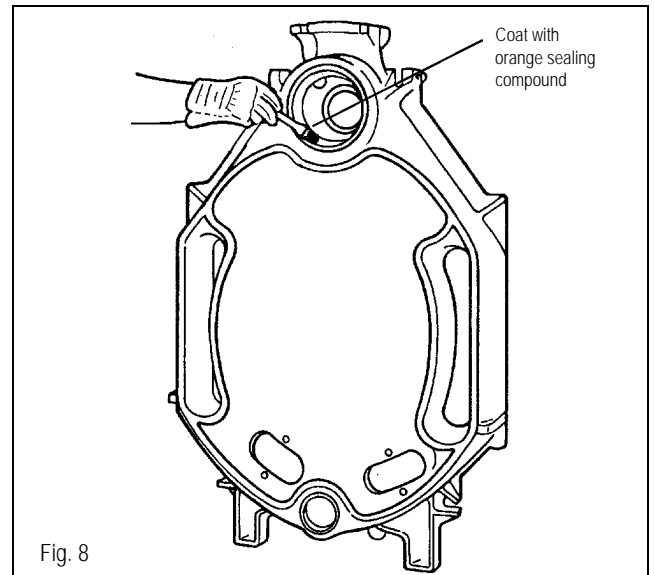

- Clean the sealing grooves for sealing the flue side of the boiler using an abrasive rag or steel wire brush. Make sure surfaces are dry, clean and free of any oily residues.
- Apply the Buderus Haftgrund Primer 181 to all sealing grooves using a small paint brush (Fig. 9).
- The sealing of the flueway of each section is achieved with the sealing cord. The sealing cord can be installed 5 to 15 minutes after the application of the primer.

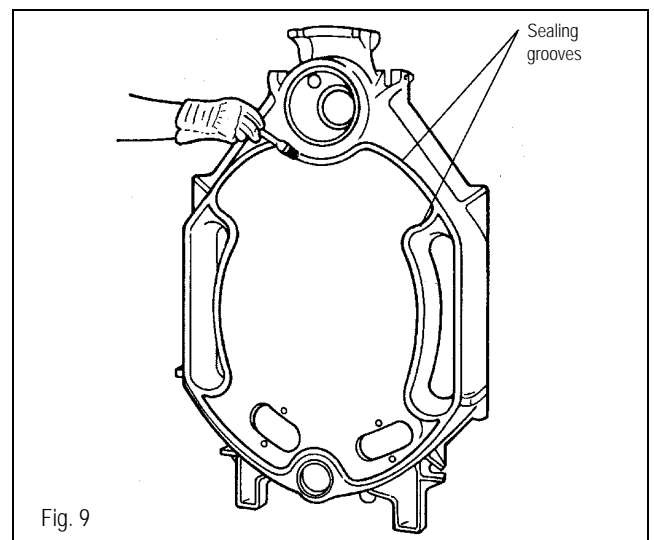

6 Boiler Assembly

- Insert the elastic sealing cord (“Dichtschnur”) into the sealing groove only on the front side of the rear section. Start at the top and press lightly to adhere to the Primer 181 (Fig. 10).
- Unroll sealing cord and remove paper backing during installation. Cut sealing cord to length with a pair of scissors or knife. Butt sealing cord ends tightly together or overlap cord ends 1” for proper sealing.
- Clean a set of push nipples with a rag soaked in thinner. Wipe dry. A set consists of the 7 1/8” x 2 3/4” top nipple and the 3 1/4” x 2” bottom nipple.
- Evenly coat slightly over half the width of the outer surface of each push nipple with the orange sealing compound.
- Insert the coated side of the nipples in the ports.
- Set nipples in place by tapping evenly with a rubber or wooden mallet. Make sure the nipples remain perfectly aligned with the boiler section (Fig. 11).

NOTE: *If a burr occurred during nipple insertion, file it off immediately!*

- Finish coating the outer surface of the push nipples with orange sealing compound.
- Clean and coat nipple ports of intermediate section with orange sealing compound. Also clean flueway sealing grooves.

This completes the preparation of the joint between the rear section and the first intermediate section.

- Check:**
1. Both push nipples installed evenly with the rear section and nipples and ports fully coated with orange sealing compound.
 2. Sealing cord is properly installed in all sealing grooves.
- Position intermediate section in front of rear section and hang from upper nipple. It may be necessary to lift up the intermediate section at the bottom with a bar. Arrow markings must point to the rear.
 - After aligning ports with push nipples, tap against the intermediate section with the mallet to seat it on the push nipples from the rear section (Fig. 12).

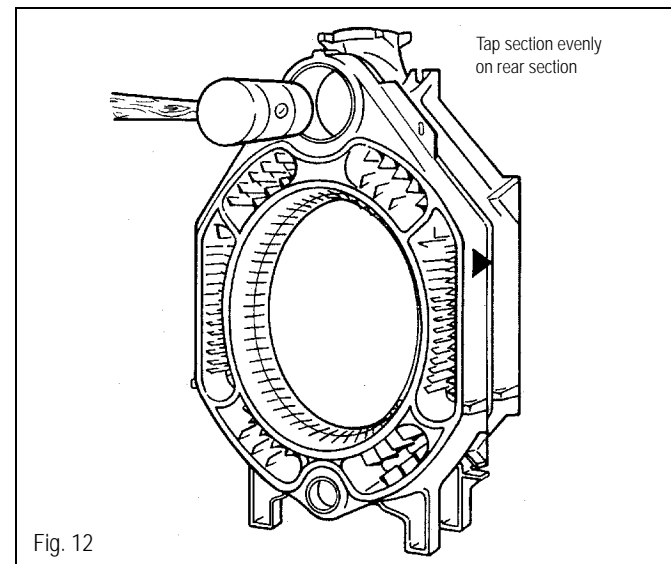
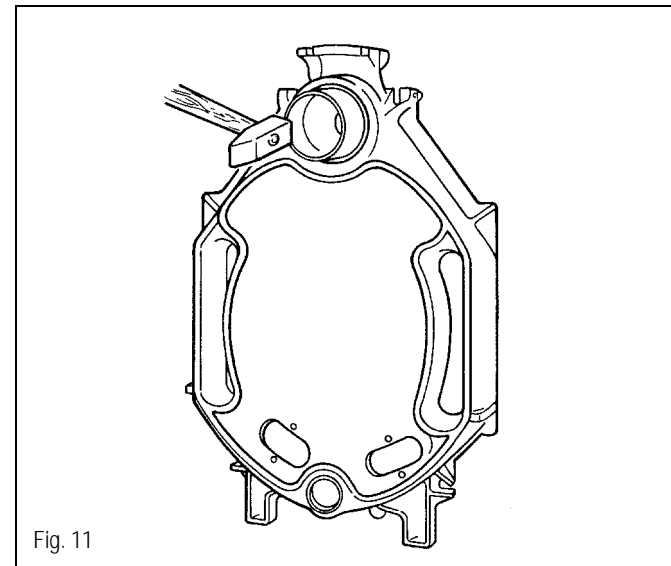
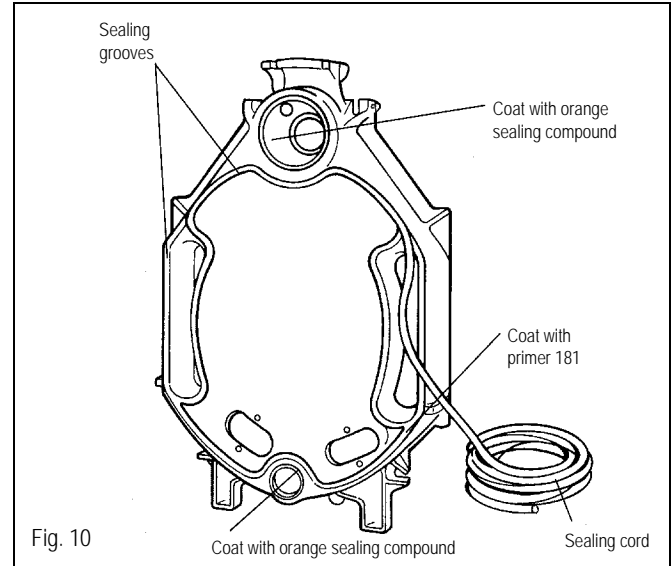

Pull sections together with boiler assembly tool

- Place assembly rods through upper and lower ports as shown (Fig. 13).
- Slide small pressure flange on each end of the lower assembly rod.
- Thread the pressure flanges on the rods.
- Slide stop flange on upper rod, insert straight pins on both rods.
- Lock flanges on assembly rods with straight pins in place by hand tightening assembly tools.
- Ensure that the tools are centered in the ports by having flanges properly located.
- Use socket wrenches provided to draw sections together evenly. Stop tightening when boiler sections abut metal to metal. Unscrew assembly tools.

NOTE: **Inspect seating to ensure nipples are seated square. Never draw more than one section at a time to avoid damage to the nipples and ports.**

- Repeat boiler assembly procedure for subsequent sections as detailed on pages 9-11.

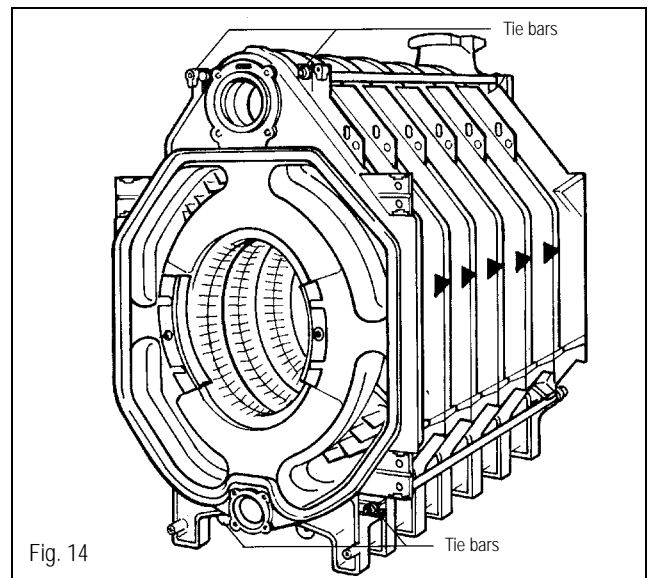
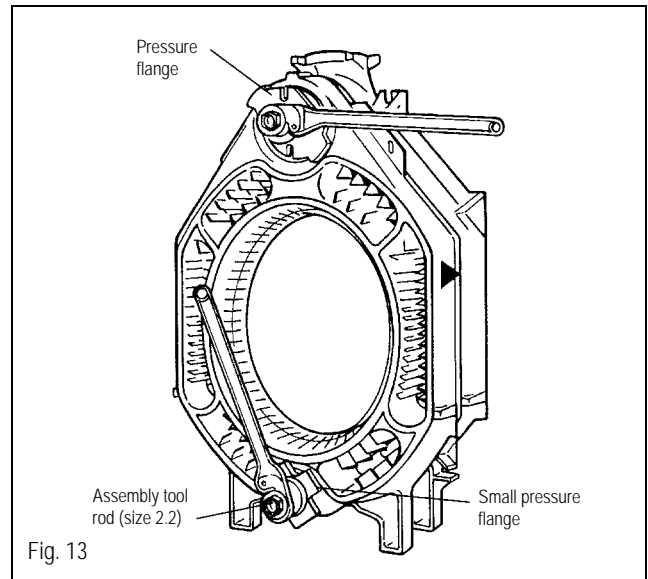

NOTE: **After the boiler block has been drawn together, loosen the tools, but do not remove.**

- Install tie bars in the cast iron slots on the left and right sides of the upper and lower nipple ports (Fig. 14).
- Slide one spring assembly on each tie bar at the front section. Do not disassemble the spring assemblies! Place a washer and nut at both ends of each tie bar.
- Hand tighten each nut first; then tighten the tie bar nuts on one end by 1 to 1^{1/2} turns with a wrench.
- Level the boiler horizontally and vertically using the provided section foot wedges. Now, remove the assembly tools.

7 Hydrostatic Test

Hydrostatic Test

Preparing for the hydrostatic test

- A pop-off relief valve is recommended on cold water feed line to prevent over pressurization.
- Install return header pipe per instructions on page 13.
- Seal the front ports with blank flanges and gaskets.
- Install return header with gasket provided (Fig. 15).
- Install supply header at the top of the rear section. See Chapter 10, page 23 for details. Install a temporary air vent (not provided) in one tapping.
- Blank off return and supply headers. (Blank flanges and gaskets not provided).
- Install fill/drain at the lower rear connection (Fig. 15).
- Install long shank well into 3/4" tapping of rear section.
- Fill the boiler. Vent the boiler at the air vent until water appears. Close the vent and pressurize the boiler.
- The assembled boiler shall be subjected to a hydrostatic test pressure not less than 1^{1/2} times the maximum allowable working pressure. The maximum test pressure shall not exceed the required test pressure by more than 10 psi.
- If a nipple port connection is leaking, bleed off test pressure, drain water through the fill/drain valve, remove the four tie and the return header pipe rods.
- Split the boiler at the leaking joint by driving chisels at the top and bottom between the sections (Fig. 16).
- Remove old nipples and clean ports as shown on page 9. Reinstall flue scaling material. Material can be reused. Reassemble per instructions on pages 10-12.

NOTE: *Always use all new nipples when reassembling the boiler*

- Repeat the hydrostatic test to ensure no leaks.
- Install relief valve after the hydrostatic test.

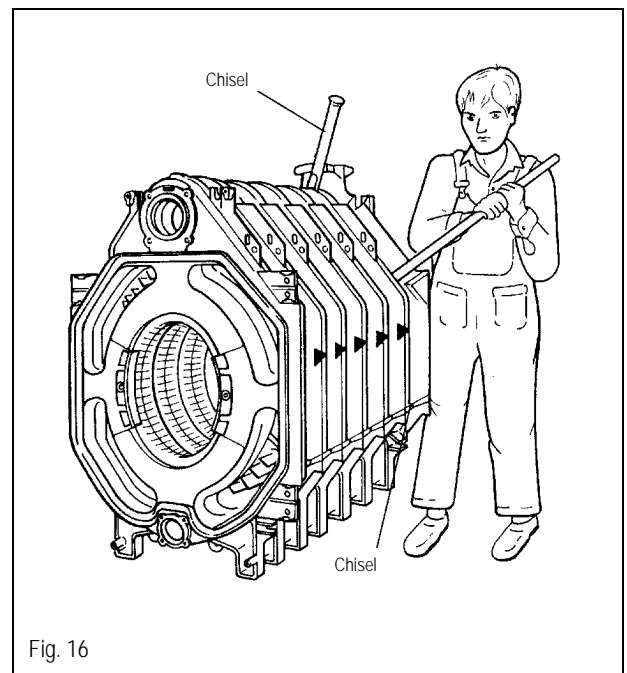
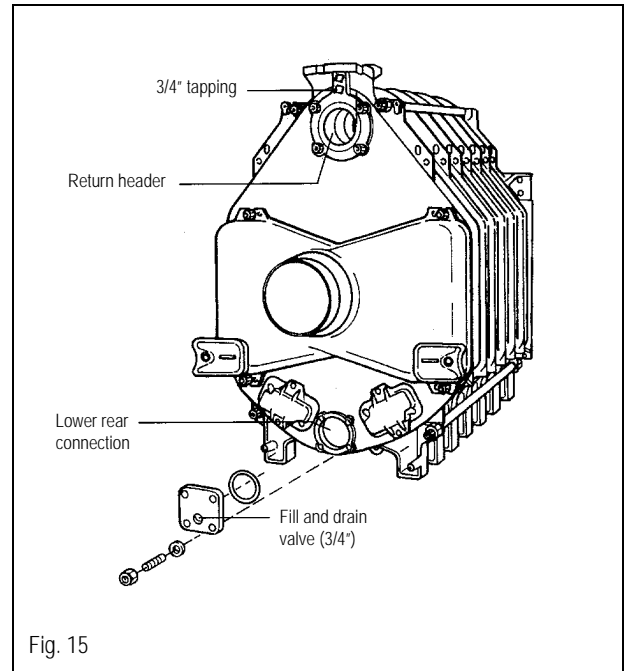

Flue gas collector installation

- The pliable sealing rope is factory installed in the collector.
- Check for damage prior to installation.
- Place the flue gas collector on the studs and tighten with washers and nuts provided to ensure a gas tight seal (Fig. 17).

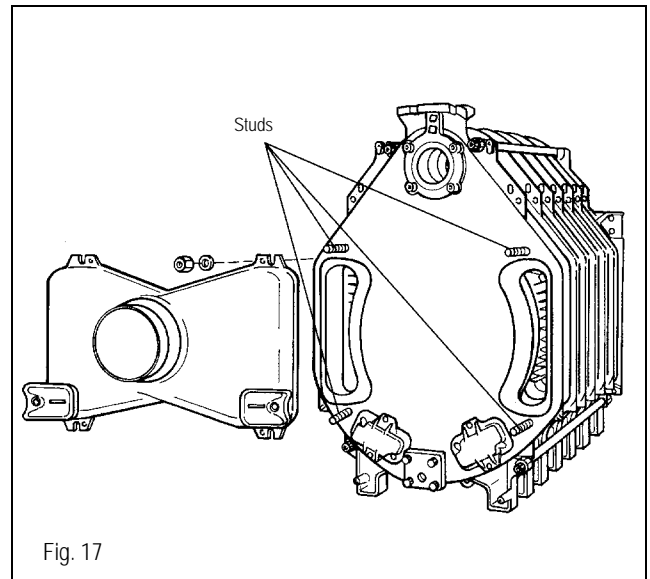

Installation of rear section clean out covers

- Install sealing ropes into grooves around cleaning covers.
- Place cleaning cover on studs provided (Fig. 18). Secure with washers and nuts provided to ensure a gas tight seal.

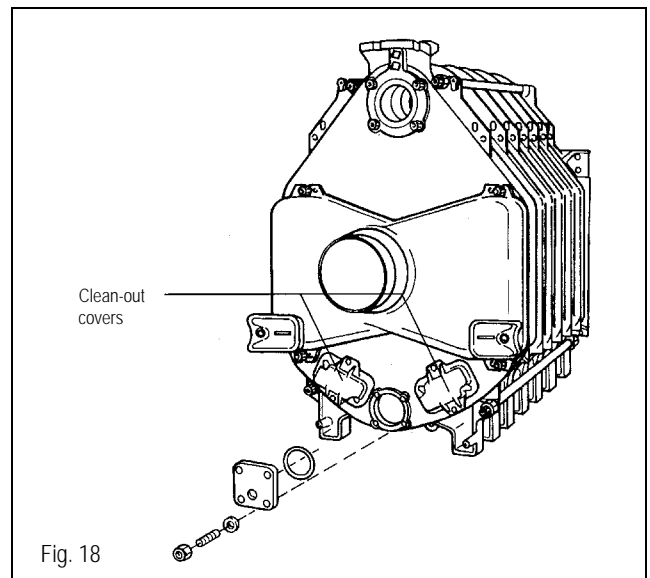

Installation of return header pipe

- Place gasket over return header pipe (Fig. 19).
- Insert the return header pipe into upper port from the front of the boiler (Fig. 19).
- The tab on the header pipe must be aligned with the recess in the front boiler section. This locks the header pipe into proper position and ensures that the outlet openings are positioned correctly to provide optimum water distribution.
- Install blank flange on studs and secure with nuts and washers.

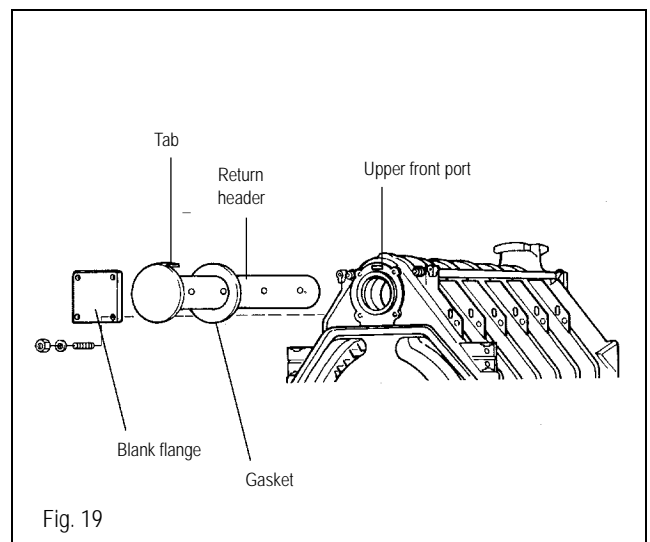

8 Installation of Boiler Components

Flue gas blocking plates at front section

- Flue gas adjustment plates or ribs are factory installed on the front section with Allen head screws (Fig. 20).

Flue gas baffle plates

- Flue gas baffle plates are factory installed in an assembled boiler. Remove corrugated card board from baffle plates and insert plates as shown in Figure 21.

NOTE: The G515/12 boiler model does **not** have flue gas baffle plates.

No. of Sections	No.	Length in Inches	Installation Location for Flue Gas Baffles
7-10	1	26 ³ / ₄	Top Right
7-10	1	26 ³ / ₄	Top Left
7-10	1	26 ³ / ₄	Bottom Right
7-10	1	26 ³ / ₄	Bottom Left
11	1	16 ³ / ₄	Top Right
11	1	16 ³ / ₄	Top Left
11	1	16 ³ / ₄	Bottom Right
11	1	16 ³ / ₄	Bottom Left

Burner Door

- Attach sealing rope to front section by applying several drops of glue (P/N 422841) every 6" in the sealing grooves surrounding the combustion chamber and the outer area of the front section (Fig. 22).
- Insert the permanent pliable sealing rope in the grooves on the front section around the combustion chamber and the outer area.
- The burner door hinge supports are factory installed on the right side. Remove and mount them on the opposite side with (2) M12x55 bolts for a left hanging door.
- Mount the door hinges to the proper side of the door. (Fig. 22).
- Hang the burner door on the door hinge supports.

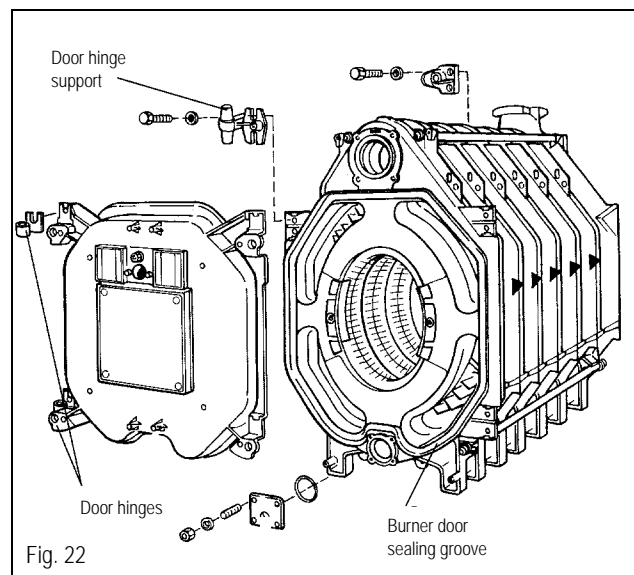
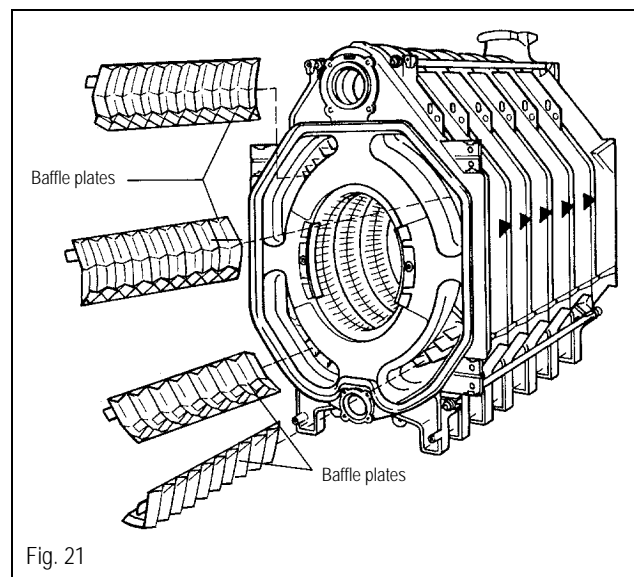
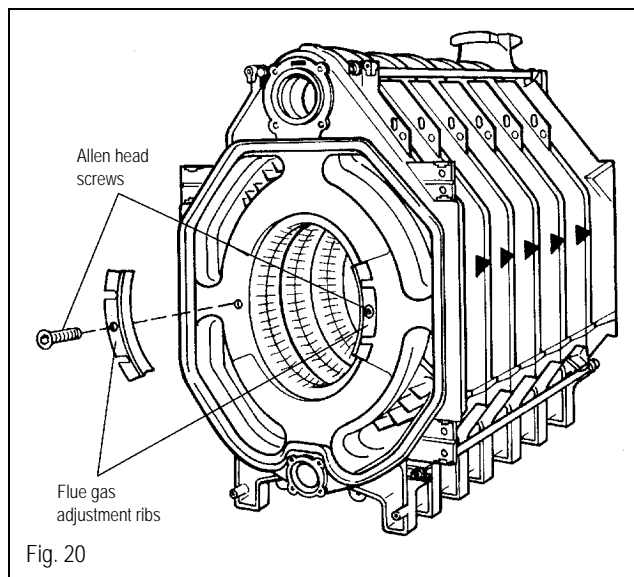

- Mount the two door strike plates on the front section, with (2) M12x55 bolts each on the opposite side from the door hinge supports (Fig. 23). The strike plates must always be pointing towards the center of the boiler.
- The strike plates change position with the door hinge supports when the burner door is to swing the other way.

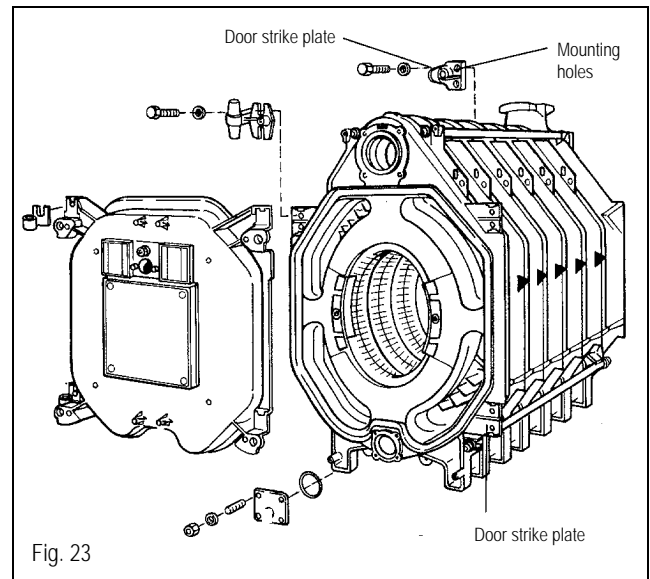

- Hang and close burner door and **tighten evenly** with the (4) M16x140 burner door bolts (Fig. 24).
- Cut and drill the burner mounting plate according to burner specifications. (The burner mounting plate can be cut by Buderus Hydronic Systems per specifications submitted with the boiler order).
- Mount burner mounting plate to burner door. Seal with 1/2" diameter sealing rope.
- Cut burner door insulation material to conform to burner tube diameter.
- Mount burner per manufacturers instructions.

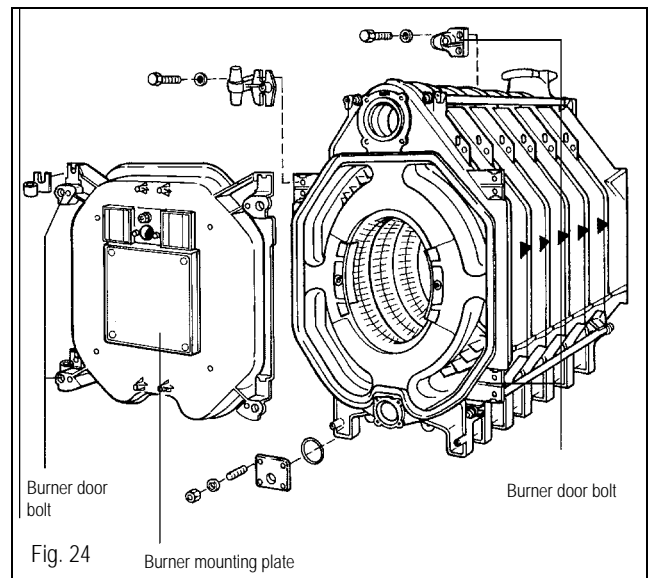

Fill burner door with insulation per instructions below.

- Cover burner tube and sight glass port with paper to prevent filling these areas.
- Mix insulating cement with water to pulp consistency.
- Fill any spaces between burner door insulation and burner tube with the insulating cement (Fig. 25).

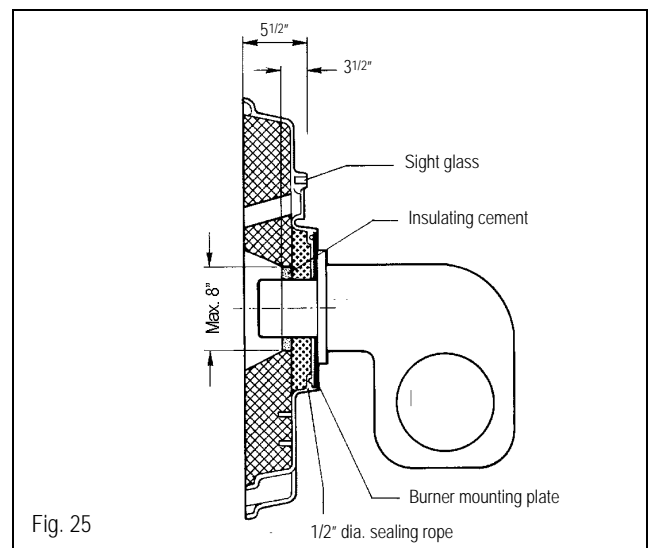

9 Installation of Insulation & Boiler Jacket Panels

Location of support brackets for jacket panels

Support brackets are mounted on the front and rear sections. Intermediate brackets are located as measured from the front section per schedule below.

No. of Sections	7	8	9	10	11	12
Location of Bracket(s)	4	4	5	5	4,7	4,8

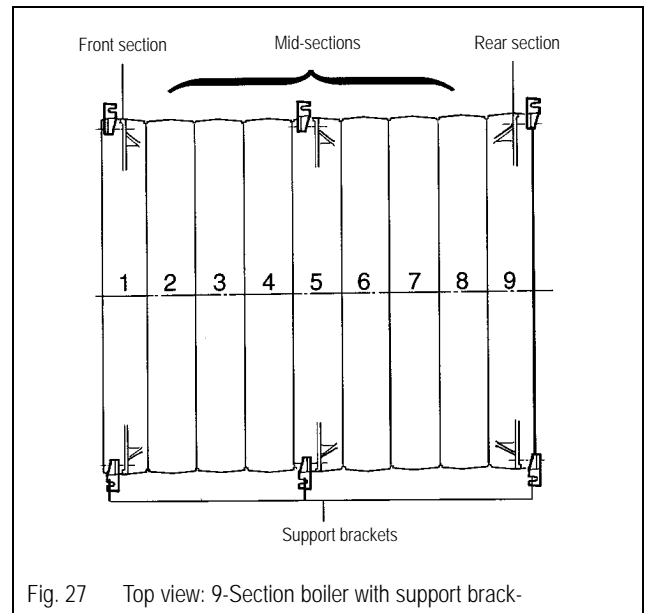

Details of insulation blankets

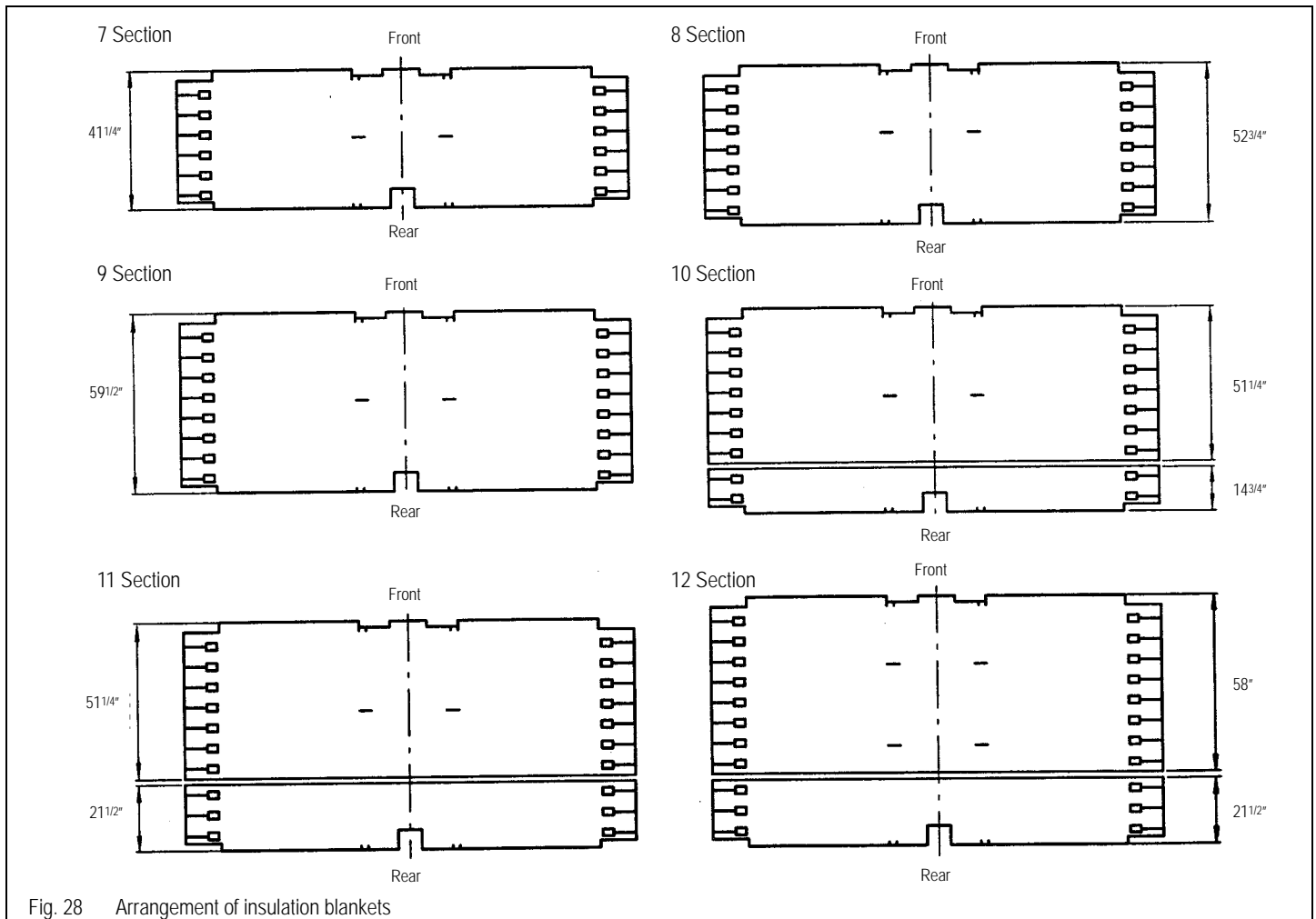
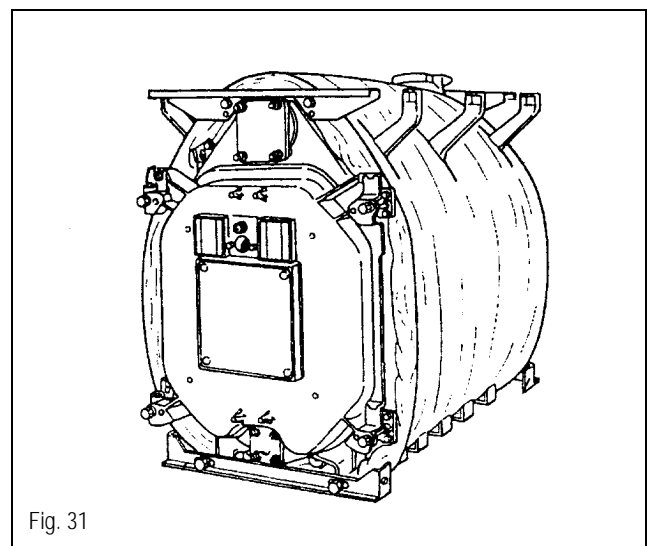
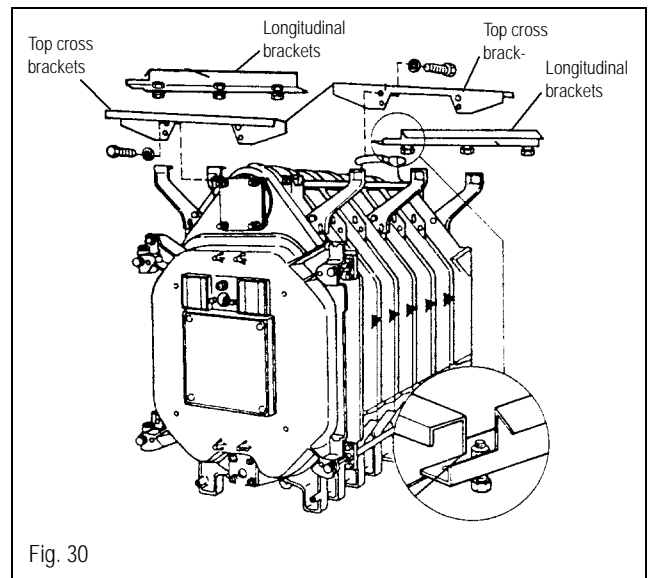
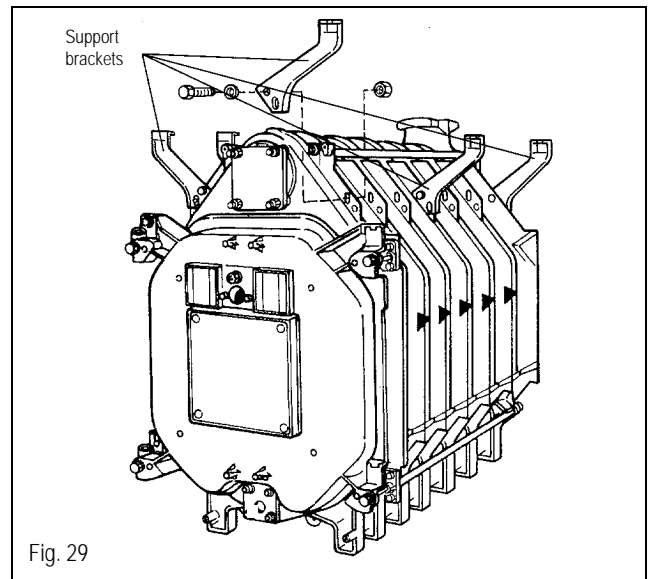

Fig. 28 Arrangement of insulation blankets

- Loosely bolt the support brackets for the jacket to the left and right of the upper ribs as detailed in Fig.'s 27 and 29, and the table on page 16.
- Support brackets for the front and mid section(s) must be mounted on the front side of the casting section. The rear support brackets must be mounted on the rear side. Longitudinal brackets are temporarily installed to locate the support brackets before tightening.
- Screw the top cross brackets to the front and rear sections with M8x16 bolts. The beveled edges must point outward (Fig. 30).
- Place the longitudinal brackets on the support brackets on the front and rear sections (Fig. 30).
- Slide the longitudinal brackets with attached mounting bolts from the front into the recesses of the support brackets, move to the rear and fasten these brackets onto the support brackets. The notched end must face the front of the boiler.
- Push the notched end of the longitudinal brackets behind the front cross bracket. Press the other end up against the rear cross bracket.
- Tighten the support brackets to the boiler sections and mark for later reference.
- Push the middle support brackets up to the longitudinal brackets and secure tightly to section ribs.
- Loosen and remove the longitudinal brackets.
- Install insulation panels according to Fig. 28.
- Press the support brackets through the insulation at the indentations (Fig. 31).
- Fold the insulation under the boiler block (Fig. 31). The boiler feet are positioned in the cut-outs of the insulation.
- Loosely screw the bottom cross brackets (front and rear) to the section feet with M8x16 bolts. The beveled edge on both bottom cross brackets must point outward (Fig. 31).



9 Installation of Insulation & Boiler Jacket Panels

- Place the front insulation piece with the cut-outs pointing up, then fasten it to the block insulation with the two tension springs (Figs 32 and 33).

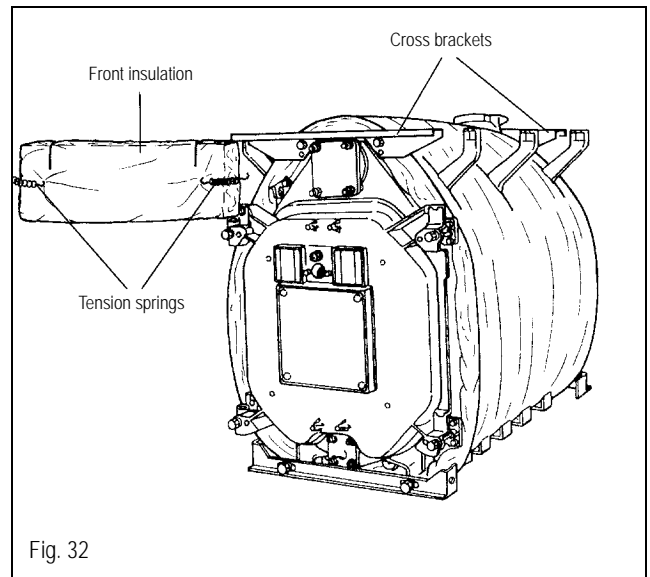

- Reinstall the longitudinal brackets on the sides as previously matched (Fig. 33).
- Slide longitudinal brackets with the attached mounting bolts from the front into the notches of the support brackets.
- Push the notched end of the longitudinal brackets behind the front cross bracket. Press the other end up against the rear cross bracket.
- Fasten the longitudinal brackets to the support brackets.

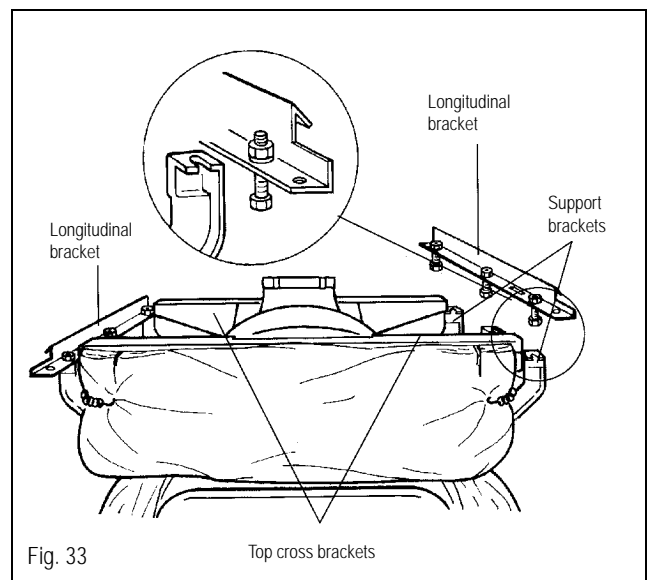

- Place the rear insulation panel with the boiler return connection cut-out upward over the vent connection as shown (Fig. 34).
- Secure the insulation panel with 4 tension springs to the boiler insulation blanket (Fig. 34).
- Close the slit in the insulation under the vent connector with a tension spring (Fig. 34).

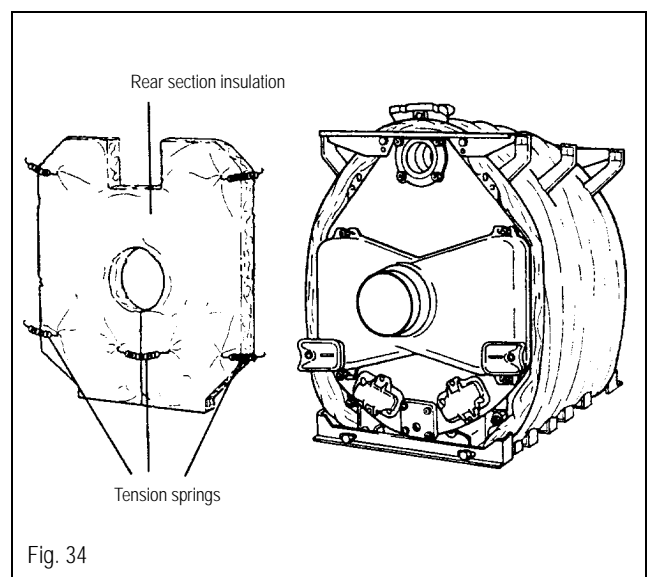

- Place the bottom side covers with the longer projecting end facing forward, against the lower cross brackets (Fig. 35).
- Screw the bottom side covers to the cross brackets with sheet metal screws (Fig. 35).
- Tighten bolts holding the cross brackets.

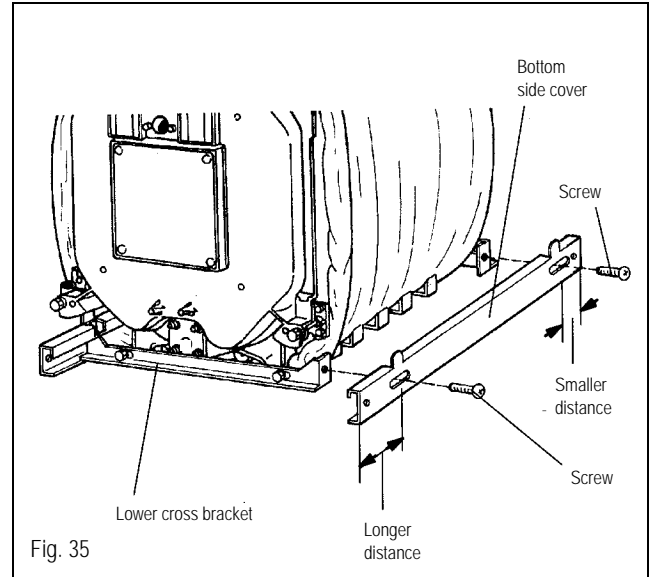

Fig. 35

Jacket Installation

Note: Be careful not to scratch the jacket panels.

- Place the hinge tabs of the side panel flap into the knockouts of the front side panel, and fasten these hinges with sheet metal screws (Fig. 36).
- Attach a tension spring to side panel flap as shown (Fig. 36).
- Repeat procedure for the other side.
- See Figure 38 (page 20) for proper side panel arrangement.

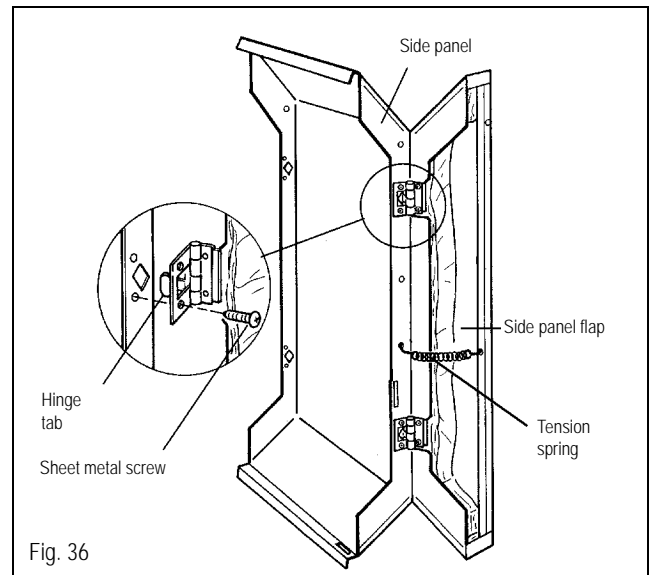

Fig. 36

- Place the bottom of the front side panels in the bent-up clips of the bottom side covers (Fig. 37). Then push the top of these side panels over the beveled edge of the longitudinal brackets. Panel will latch in place.
- Refer to Figure 38 on page 20 for side panel arrangement for different boiler models.
- Mount panels from front to back.

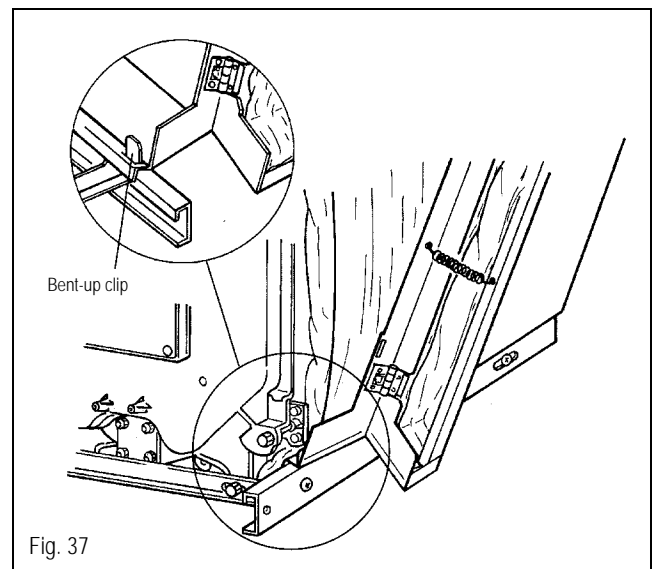
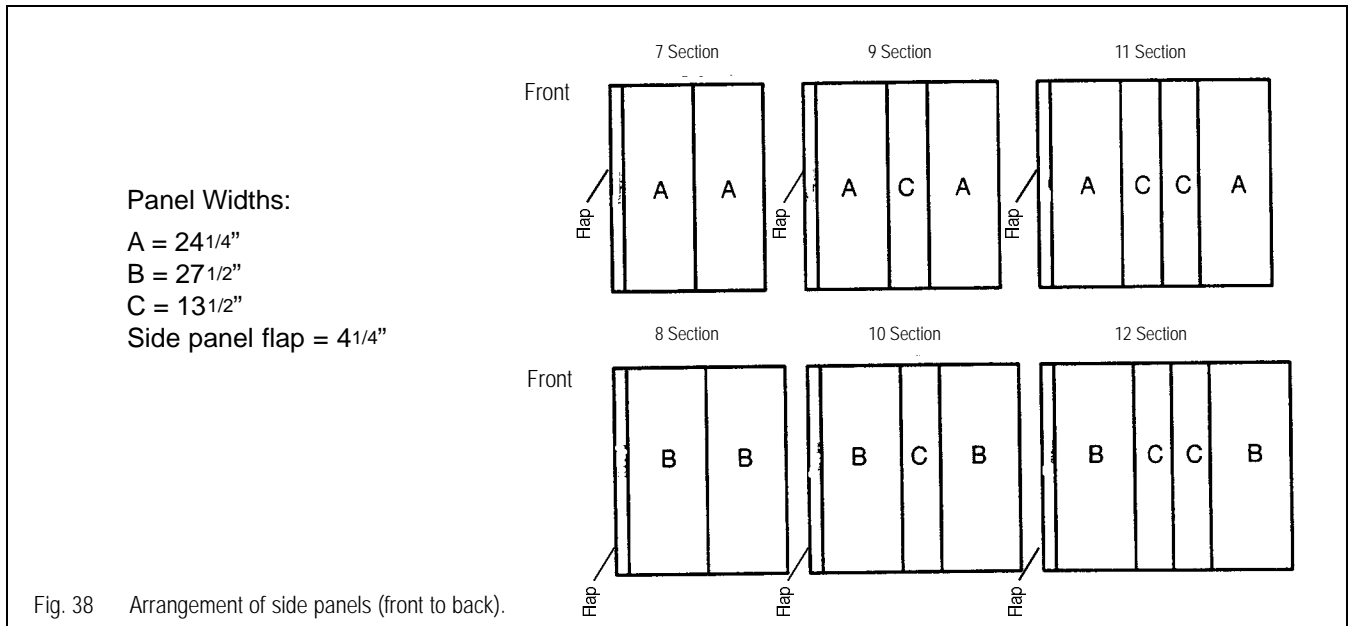
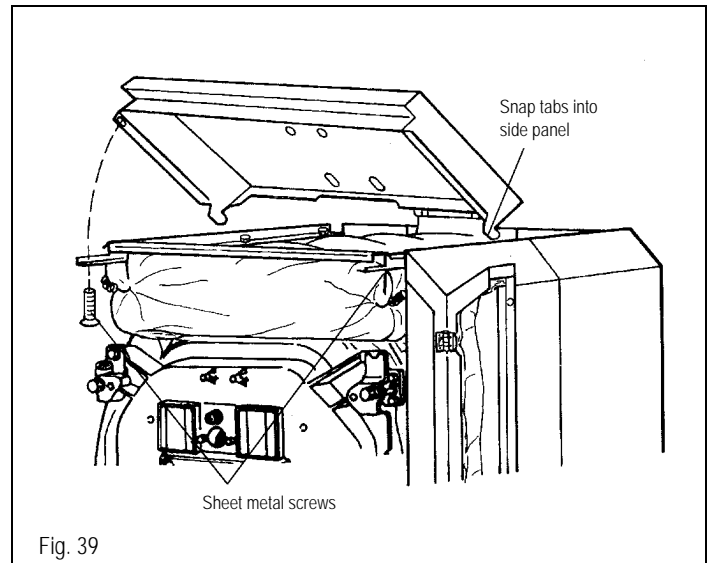

Fig. 37

9 Installation of Insulation & Boiler Jacket Panels



- Hook the front top cover with both tabs into the front side panels as shown in Figure 39.
- Fasten the front top cover to the longitudinal with two sheet metal screws (Fig. 39).



- Insert the beveled edges of the middle top cover under the front top cover and position between the side panels (Fig. 40).

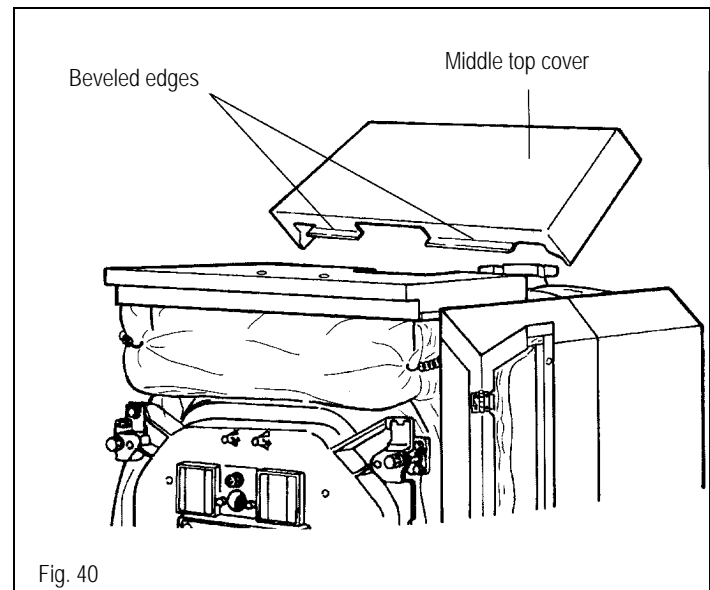

- Place the rear top cover with the beveled edges and supply cut-out toward the front on top of the side panels (Fig. 41).

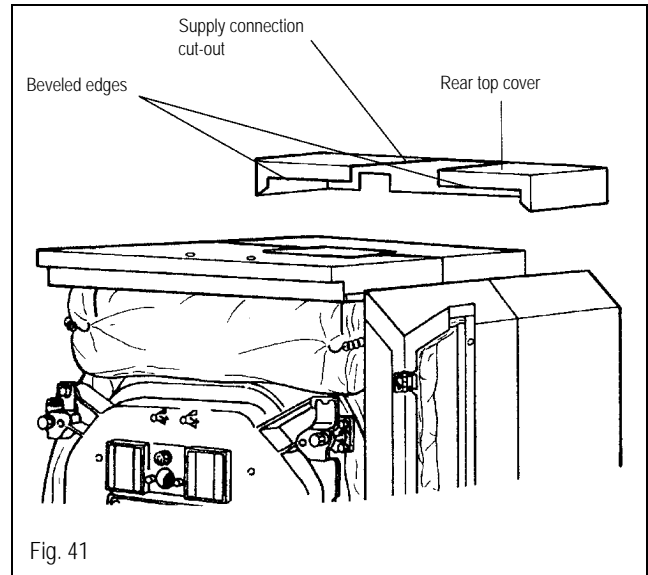

- Slide the top back panel underneath the rear top cover and attach this panel with four sheet metal screws to the side panels (Fig. 42).

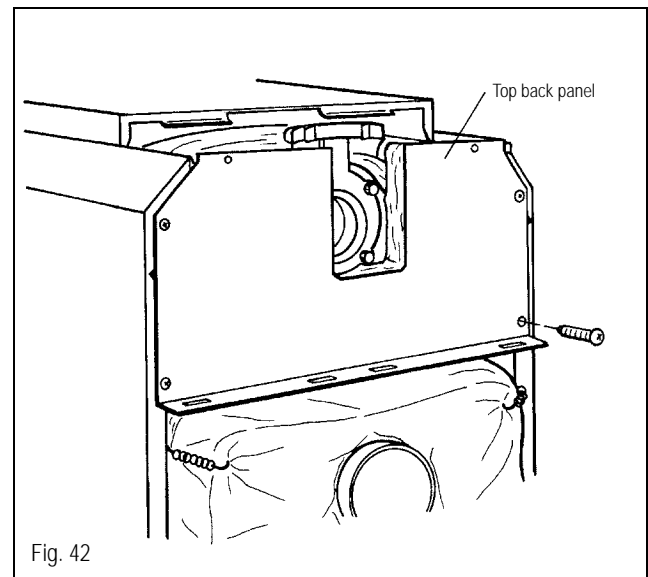

- Install snap-on nuts in the left and right side panels as shown (Fig. 43).
- Hang the lower right and left back jacket panels into the slots from the beveled edge of the top back panel (Fig. 43).
- Secure with sheet metal screws installed in the snap-on nuts (Fig. 43).
- Attach small connecting plate between both lower back jacket panels with sheet metal screws (Fig. 43).
- Screw cable raceway to the top back panel (Fig. 43).

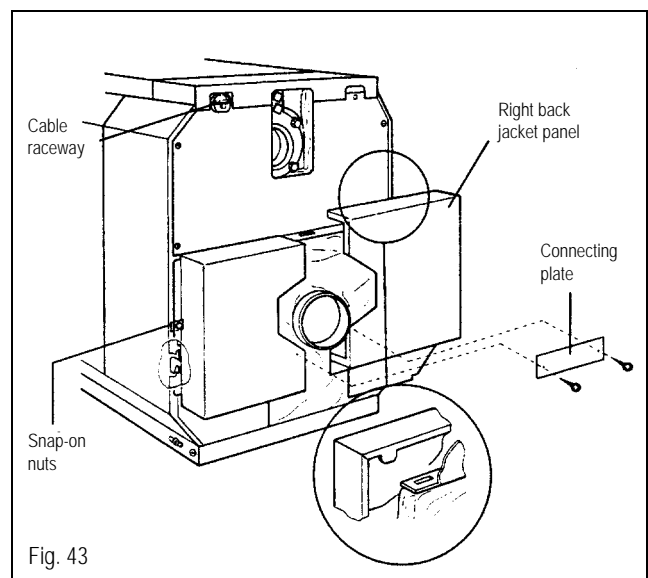

9 Installation of Insulation & Boiler Jacket Panels

- Slide the front and rear bottom cover plates into the longitudinal bottom covers. The beveled edge must be at the bottom and point towards the boiler (Fig. 44). Secure with sheet metal screws.

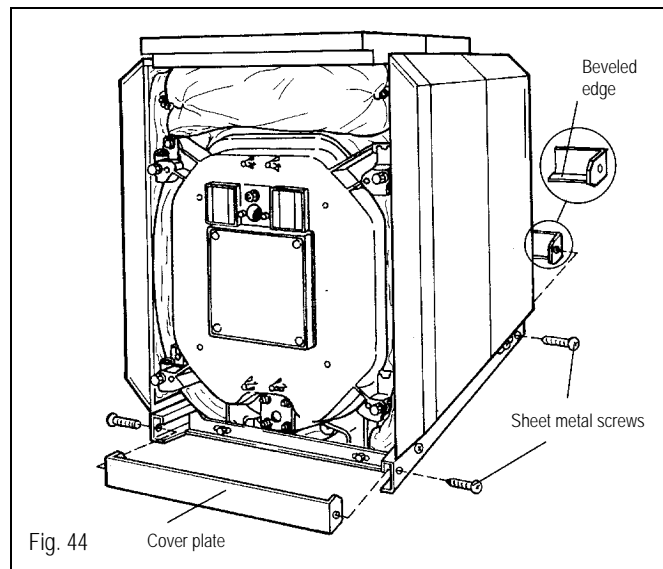

- Mount the two burner door panels to the burner door with four machine screws (Fig. 45).

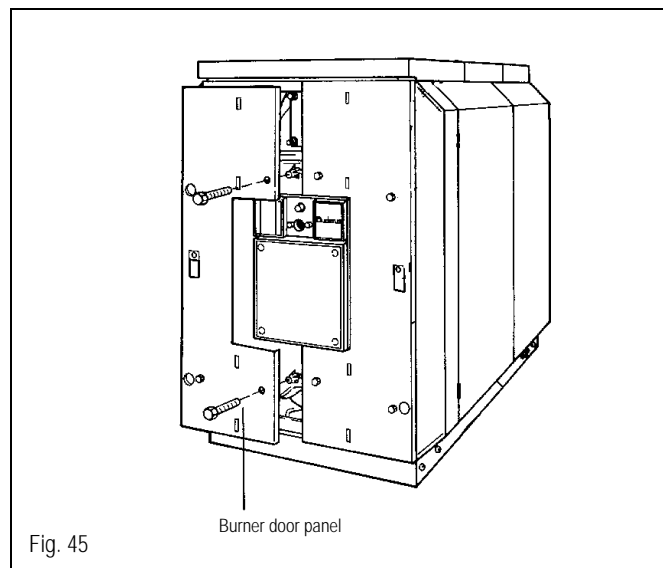

- Hang the burner door covers into the burner door panels as shown (Fig. 46).

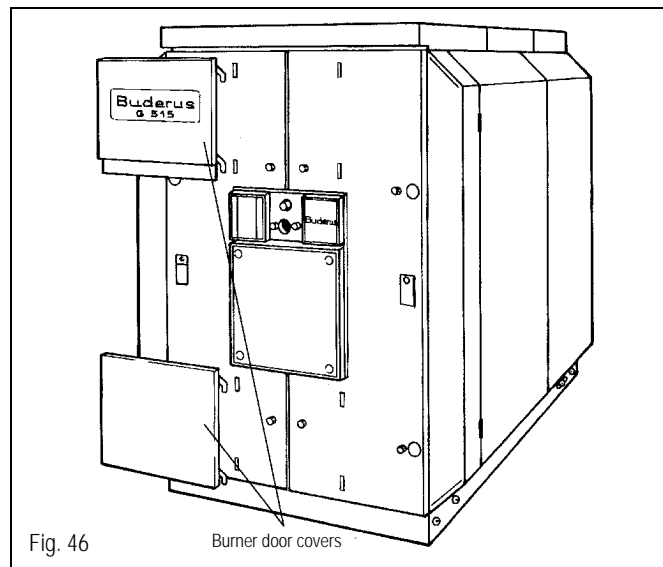

Installation of supply header and controls

- Refer to Figure 47 for details.
- Fasten supply header with supplied bolts and gasket to supply connection in desired orientation.
- Install low water cut-off probe and P&T gauge in appropriate tapplings.
- * Install relief valve after performing the hydrostatic test.
- Pipe the relief valve discharge to a floor drain in accordance with local code requirements.
- Install required number of 3/4" immersion wells in supply header tapplings.

NOTE: If Buderus Ecomatic is used, install Ecomatic well in designated tapping.

- Install the L4006E1109 manual reset high limit in rear boiler tapping.
- Install the supply temperature control aquastat (if required) in the 3/4" Ecomatic well tapping or other 3/4" tapping.
- Install L4006A1058 operating aquastat in another 3/4" immersion well. (Install second L4006A1058 aquastat for LHL burner operation).
- Plug all unused tapplings.

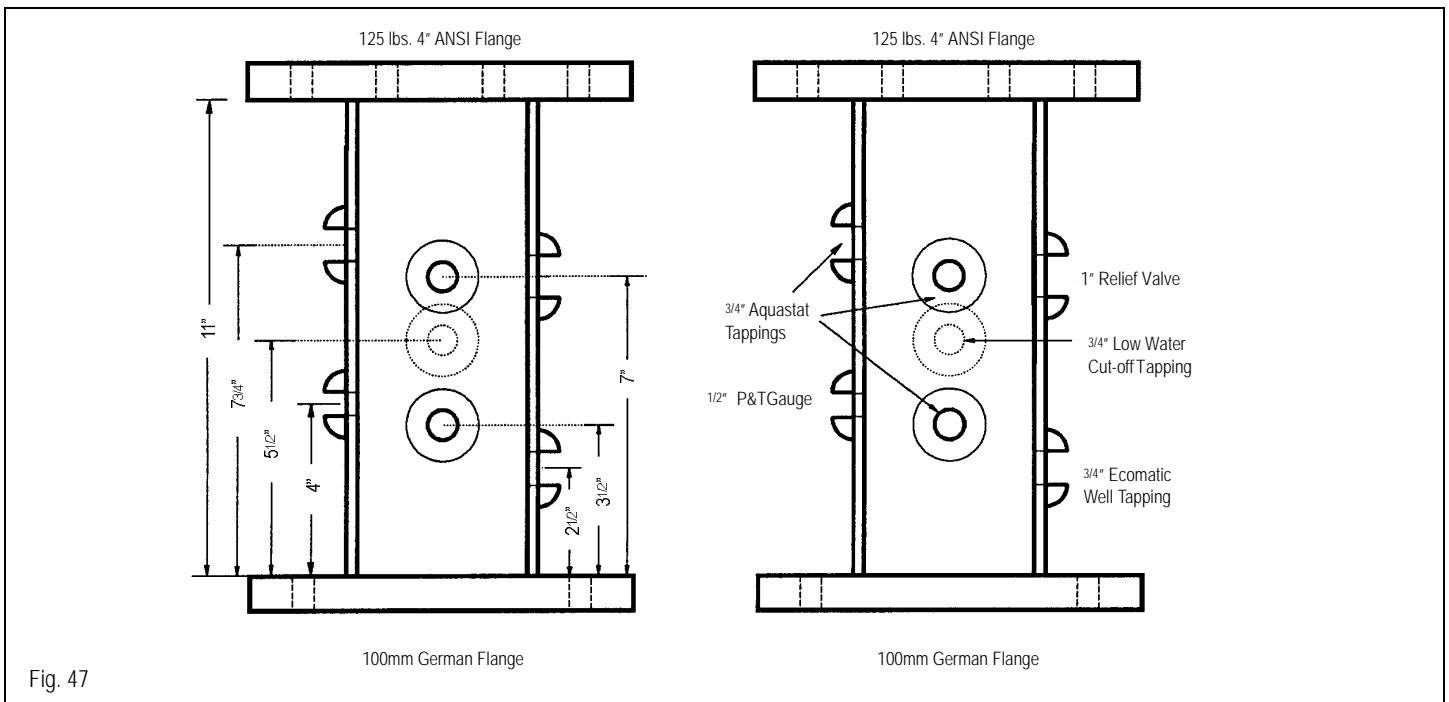

Fig. 47

11 Maintenance Instructions

Maintenance of boiler

Check burner operation on a regular basis. Verify efficiency of boiler and ensure soot free operation. Inspect flue way passages.

Clean boiler annually.

Cleaning brushes are available from Buderus Hydronic Systems.

Boiler cleaning with brushes

- Disconnect electricity. (Disconnect main system switch and padlock open to prevent the burner from being energized during service).
- Disconnect fuel supply and electrical wires to the burner.
- Remove the four bolts from the burner door (Fig. 48).

* Swing open burner door.

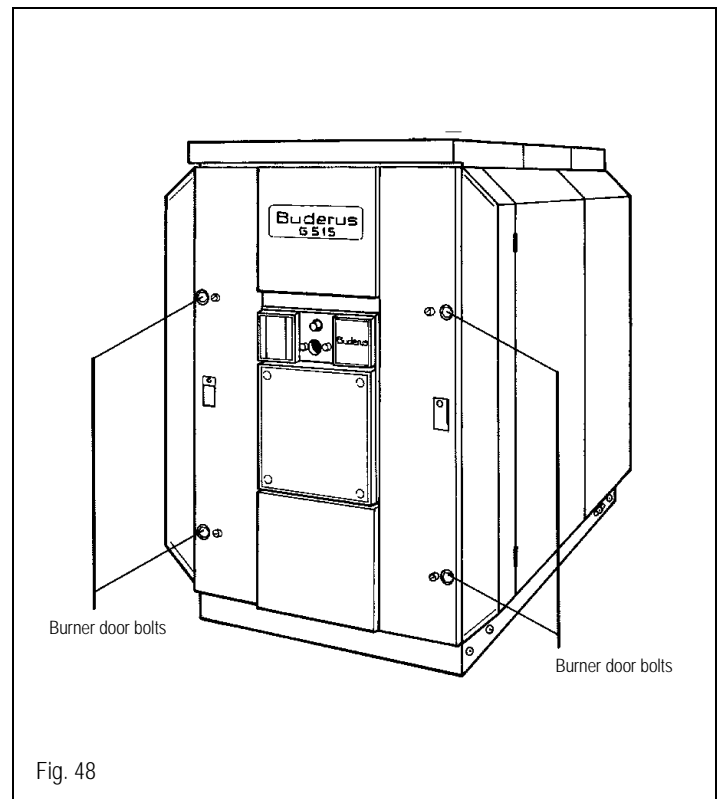
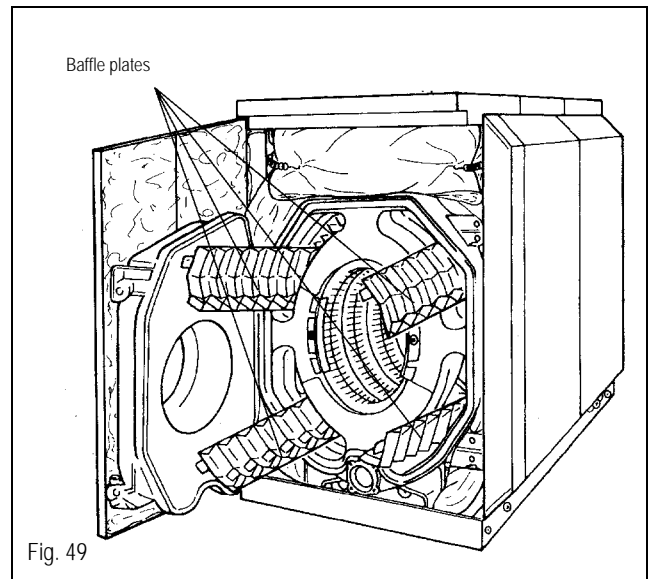

Fig. 48

- Remove flue gas baffle plates from secondary heat exchanger as shown (Fig. 49).

NOTE: The G515/12 model boiler does NOT have flue gas baffle plates.



- Remove the screws from the small connecting plate at the lower back of the boiler. Remove the connecting plate (see Fig. 43).
- Remove screws from lower back jacket panels, tilt panels upward and remove (see Fig. 43).
- Remove tension spring assemblies below vent connection, lift the insulation upward to expose clean-out cover, and fasten with springs as shown (Fig. 50).
- Remove clean-out covers from back section and flue gas collector.

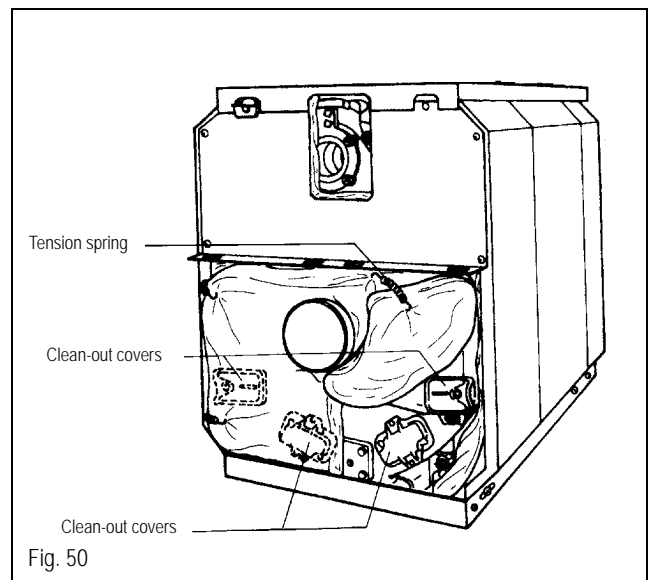

- The required brushes necessary for cleaning are as shown (Fig. 51).

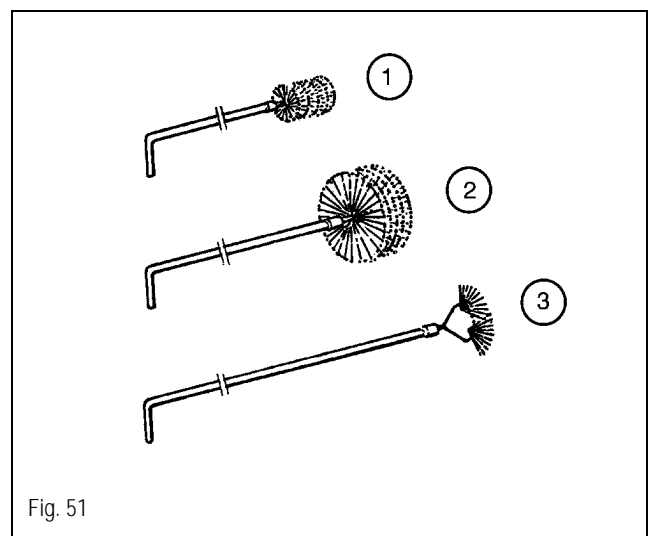

11 Maintenance Instructions

- Brush top secondary heat exchanger passages with brushes #1 and #2 (Fig. 52).
- Clean the rear wall of the combustion chamber with brush #3.
- Clean sides of combustion chamber with brush #2.
- Remove deposits and soot from flue collector.
- Brush the lower flue passages from the front and rear with brush #2 (Fig. 53).
- Remove all deposits and soot from combustion chamber and passages.
- Check integrity of sealing ropes of clean-out covers and burner door. Replace sealing ropes if damaged or hardened by contacting Buderus Hydronic Systems.
- Insert flue gas baffles. See page 14 for details. The 515/12 does **not** have baffles.
- Reinstall clean-out covers and secure burner door. Tighten bolts and screws evenly. Reinstall back jacket panels.

Wet cleaning procedure

- Follow the above procedure for accessing the boiler to perform a wet cleaning of the boiler. Follow cleaning agent instructions.

Water level control

- Maintain water pressure within the required levels.
- Verify system water level; add water and vent as needed. Automatically add water to system and vent during operation. Determine and correct problem if continuous make-up water must be added to the system.

Note: Continuous make-up water indicates a leak in the system. This causes corrosive damage to all system components and must be solved immediately.

Warranty voided if problem is not corrected.

Fill and make-up water requirements

- Fill and make-up water must comply with the requirements listed on page 4.

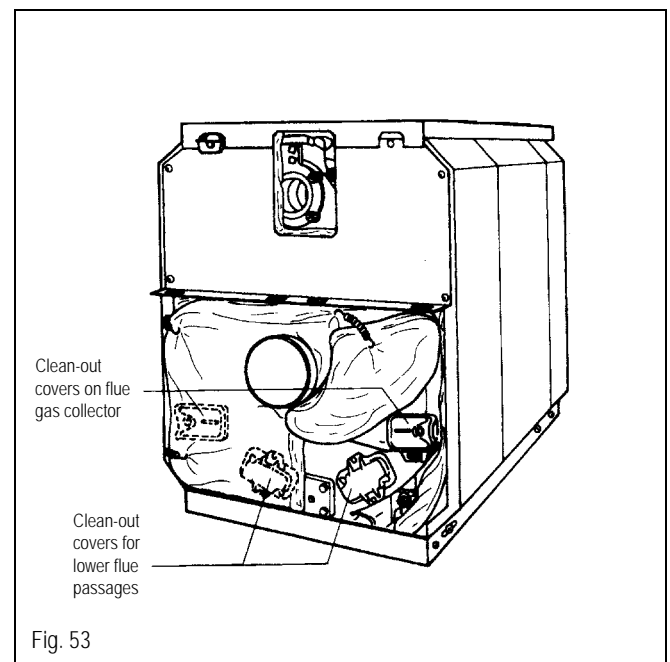
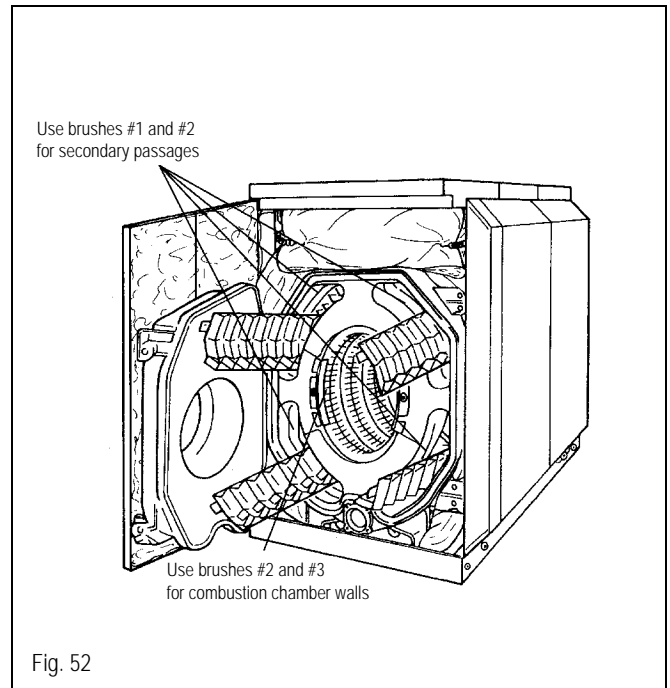

Increasing the stack temperature

- Disconnect the boiler from operation as described previously.

Maximum increase in stack temperature

- Remove both flue gas blocking plates in the front section with an Allen wrench (Fig. 54).

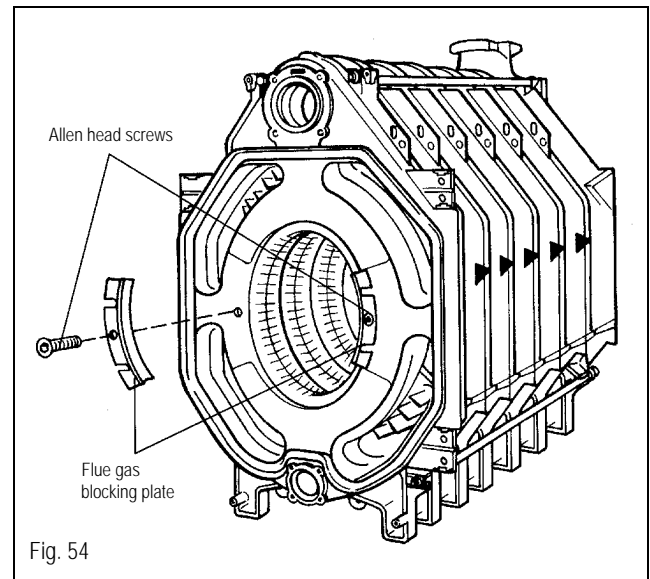

Gradual increase in stack temperature

- Remove both flue gas blocking plates in the front section with an Allen wrench (Fig. 54).
- Place the blocking plates on a solid support and remove one or more segments at the notch with a hammer and chisel (Fig. 55).
- Install the remaining plates back into the front section.
- Remove additional segments to further increase the stack temperature.
- Do not reinstall blocking plates for maximum temperature increase.

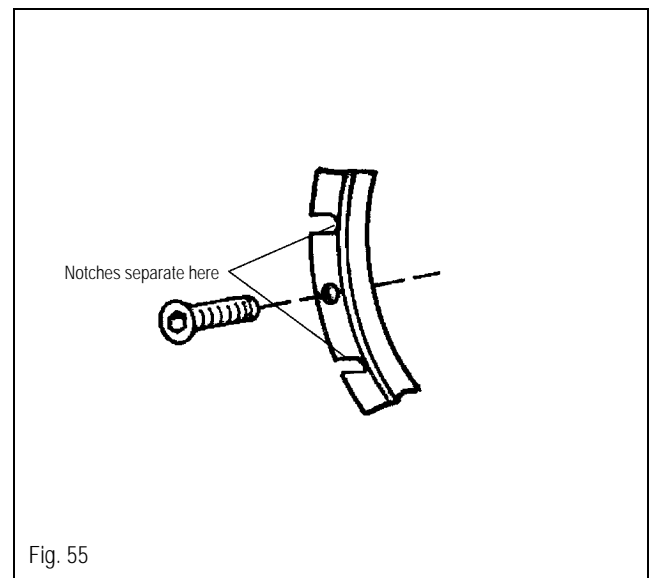

13 Optional Noise Reduction Equipment

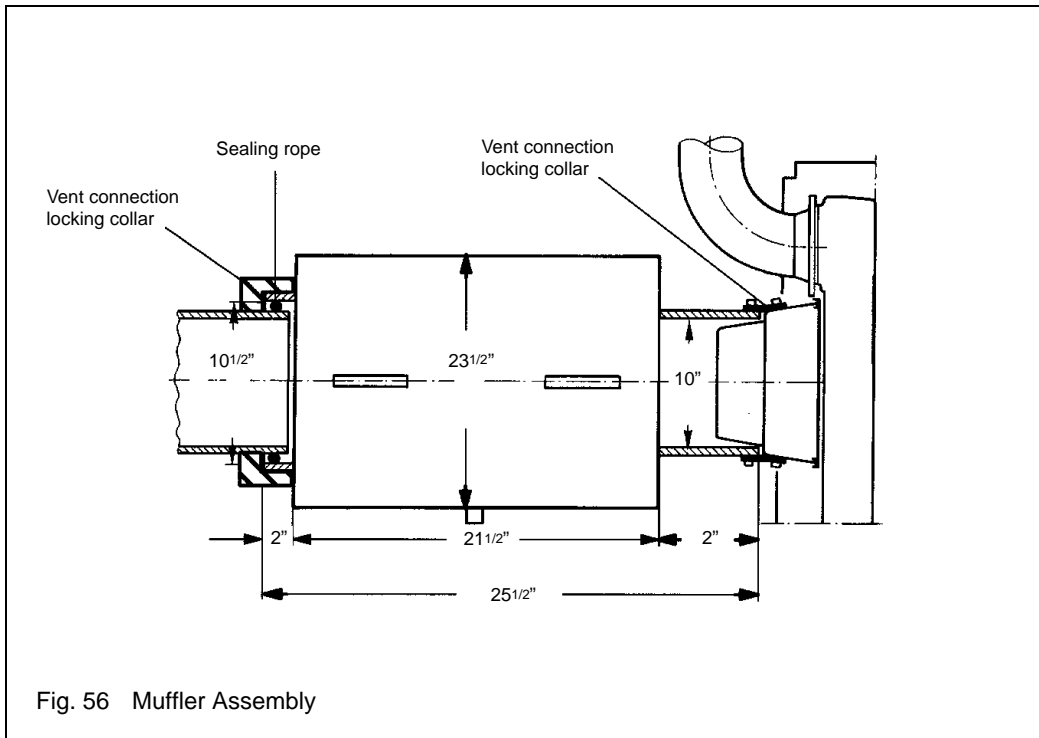

Components not in stock. Allow 4-6 weeks for delivery.

Table 6. Shipping Component Reference Table

Boiler Model	G515/7	G515/8	G515/9	G515/10	G515/11	G515/12
Back, Front Sections & Burner Door	1	1	1	1	1	1
Mid Sections	5	6	7	8	9	10
Jacket Pack A 5078600	1		1		1	
Jacket Pack B 5078602		1		1		1
Jacket Pack C 5078604			1	1	2	2
Insulation	5078440	5078442	5078444	5078446	5078448	5078450
Accessory Box	5621792	5621794	5621796	5621798	5621800	5621801
Flue Collector	5321792	5321792	5321792	5321792	5321792	5321792
Mounting Parts	5621780	5621782	5621784	5621786	5621788	5621790
Tie Bars	5127540	5127542	5127544	5127546	5127548	5127550
Supply & Return Headers & Controls	1	1	1	1	1	1

Brief description of individual shipping components

Skid 1: Front and rear sections and burner door.

Skid 2: Required number of mid-sections.

Jacket packs A and B: Hardware components for boiler jacket installation.

Jacket pack C: Middle sections of the side panels needed for the larger boiler models.

Accessory box: All hardware components needed to assemble the boiler. Boiler blanking flanges and gaskets are found here.

Mounting parts box: Return distribution pipe and the full boiler length brackets needed for boiler jacket installation.

Tie bars: Bundle of 4 threaded rods to hold sections together.

Header and control box: Supply and return headers with optionally ordered control components.

15 Supply Temperature Control

Supply temperature control

An “Open-On-Rise” aquastat is required to interrupt water circulation through the boiler to prevent the supply temperature from dropping below 122°F during burner operation. The aquastat is to temporarily stop operation of the main system pump (or individual boiler pumps in case of a multiple boiler installation).

Refer to Figure 57 for a typical control schematic for a single boiler with supply temperature control. Control components can be furnished by Buderus Hydronic Systems, Inc.; relay, burner and circulator operating controls can not be provided.

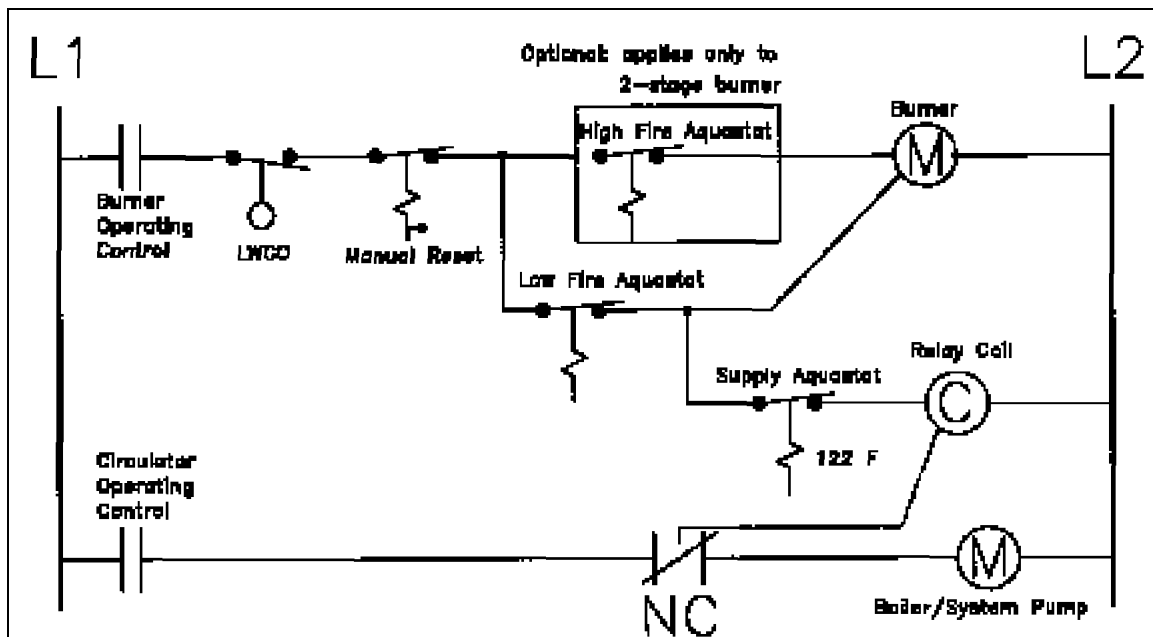

Fig. 57 Typical Control Schematic

Heating Contractor:

PRODUCTS MANUFACTURED BY

BBT Thermotechnik GmbH
35573 Wetzlar
www.buderus.de

Buderus

BBT North America Corporation
50 Wentworth Avenue
Londonderry, NH 03053
Tel: 603-552-1100 • Fax: 603-584-1681
www.buderus.net

*BBT North America Corporation reserves the right to make changes without notice
due to continuing engineering and technological advances.*