

Installation and Service Instructions

Function module

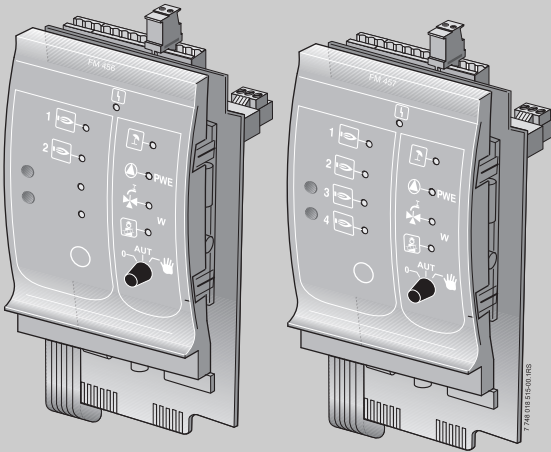

FM456
FM457

For heating contractors

Read carefully prior to
commissioning and
service work

1	Safety	4
1.1	About this manual	4
1.2	Intended use	4
1.3	Standards, regulations and directives	4
1.4	Key to symbols	5
1.5	Please observe these notes.	6
1.6	Disposal	7
2	Product description.	8
3	Installation	14
3.1	Scope of delivery	14
3.2	Checking the software versions	15
3.3	Installation in the Logamatic 4323 control panel	15
3.4	Connecting inputs and outputs	16
3.5	Connecting sensors	17
3.6	Connecting EMS boilers.	18
4	Burner control and basic operation	19
4.1	BC10 base controller (EMS).	20
4.2	Approved boiler types	22
5	General data	23
5.1	0 – 10 V input	23
5.2	Temperature/output control 0 – 10 V input.	25
5.3	Power control for 0 – 10 V input	27
6	Boiler data.	31
6.1	Number of boilers.	31
6.2	Hydraulics (for single-boiler system)	32
6.3	Hydraulics (for multi-boiler systems)	34
6.4	Detection of auxiliary heat	35
6.5	Boiler type	36
6.6	Limiting boiler output	38
6.7	Maximum boiler temperature	39
6.8	Setting the type of sequence control	40

7	DHW data	43
7.1	Selecting the DHW storage tank.	43
7.2	Set temperature range.	45
7.3	Selecting switching optimization	47
7.4	Selecting leftover heat use	48
7.5	Setting differential	50
7.6	Selecting and setting thermal disinfection	51
7.7	Setting disinfection temperature	53
7.8	Setting day of week for disinfection	54
7.9	Setting time of day for disinfection	55
7.10	Daily heating	57
7.11	Selecting the recirculation pump	58
7.12	Setting the recirculation pump intervals.	60
8	Relay test	62
9	Fault messages.	67
10	Actual data	68
10.1	Low loss header monitor data	68
10.2	Boiler monitor data.	69
10.3	Additional fault messages with EMS	73
10.4	Service messages for boilers with EMS	76
11	Sensor characteristics	80
12	Index	82

1 Safety

1.1 About this manual

This section contains general safety instructions that you must observe when servicing the FM456 and FM457 function modules.

The other sections of the service instructions contain additional safety instructions that must also be observed. Read the safety instructions carefully before carrying out the activities described below.

If the safety instructions are not observed, serious or even fatal personal injury and damage to property and the environment may be caused.

1.2 Intended use

You can install the FM456 and FM457 function modules in the 4323 control panel of the Logamatic 4000 control system.

The function modules can be used according to the following table:

Control Panel	FM456/FM457
4323	up to 2 each or in combination

Tab. 1 Deployment possibilities

1.3 Standards, regulations and directives



USER NOTE

Observe all regulations and standards applicable to installation and operation of the system in your country.

**USER NOTE**

All electrical components must be approved for the USA and Canada!



This product has been tested and certified and meets applicable standards for the US and Canadian markets.

1.4 Key to symbols

Two levels of danger are identified and signified by the following terms:

**WARNING!****RISK OF LIFE**

Identifies possible dangers emanating from a product that might cause serious injury or death if appropriate care is not taken.

**CAUTION!****RISK OF INJURY/
SYSTEM DAMAGE**

Indicates a potentially dangerous situation that could cause minor or moderately serious injuries or damage to property.

**USER NOTE**

Tip for optimum use of equipment and adjustment as well as useful information.

1.5 Please observe these notes

The FM456 and FM457 function modules have been designed and manufactured in accordance with currently recognized standards and safety requirements.

However, damage resulting from improper service work cannot be completely prevented.

Read these service instructions thoroughly before starting any service work on the FM456 and FM457 function modules.



WARNING!

RISK OF LIFE

due to electric shock!

- The installation, electrical wiring, commissioning, electrical connection, as well as maintenance and repairs must only be carried out by a trained contractor who adheres to all current technical regulations and requirements.
- The local regulations must be observed.



WARNING!

RISK OF LIFE

due to electric shock!

- Make sure that all electrical work is carried out by a trained contractor.
- Before opening the control panel: isolate all poles of the power supply and secure against accidental reconnection.



WARNING!

RISK OF LIFE

due to electric shock!

The risk of voltage transfers between the line voltage (120 V) and the low voltage wiring through accidental loosening of the wires at the terminals must be prevented.

- Therefore secure individual cables together in bundles (e.g. with cable ties) or strip off only a minimum of the outer insulation.

**CAUTION!****RISK OF INJURY/
SYSTEM DAMAGE**

due to operator error!

Operator errors can cause injury and damage to property.

- Ensure that children never operate the appliance unsupervised or play with it.
- Ensure that only personnel trained to operate the appliance correctly have access to it.

**CAUTION!****DEVICE DAMAGE**

through electrostatic discharge (ESD).

- Before unpacking the module, touch a radiator or a grounded metal water pipe to discharge any electrostatic charge in your body.

**USER NOTE**

Ensure that a circuit breaker is available to disconnect all poles from the mains power supply. If there is no circuit breaker, you will need to install one.

**USER NOTE**

Only use original Buderus spare parts. Damage caused by the use of parts not supplied by Buderus is excluded from the Buderus warranty.

1.6 Disposal

- Electronic components do not belong in household waste. Dispose of defunct modules correctly through an authorized disposal site.

2 Product description

FM456 and FM457 function modules (accessories)

With these KSE modules (cascade modules) it is possible to control multiple wall-mounted or floorstanding boilers with EMS/UBA 3 (FM456: up to 2 boilers, FM457: up to 4 boilers). The wall-mounted boilers can have different outputs.

Up to 2 function modules can be used in a single control panel (→ Tab. 1, page 4). This way, a maximum of 8 boilers can be operated (for information about the ECOCAN-BUS networking of control panels with FM456/457, see the service instructions of the corresponding control panel. See especially the chapter about "Modules and their functions").

Additional module functions are:

The FM456 and FM457 include a heating zone without mixing valve. You cannot connect a remote control unit for this heating zone. The pump for this heating zone is using the 120 V pump output.

Via the 0 – 10 V input, external set point control (temperature or output) is possible (→ Fig 2, page 10).



USER NOTE

To avoid generating undefined input values, never apply voltages greater than 10 V to the 0 – 10 V input.



USER NOTE

You can adapt the curve if desired (→ Chapter 5.2).

Front panel

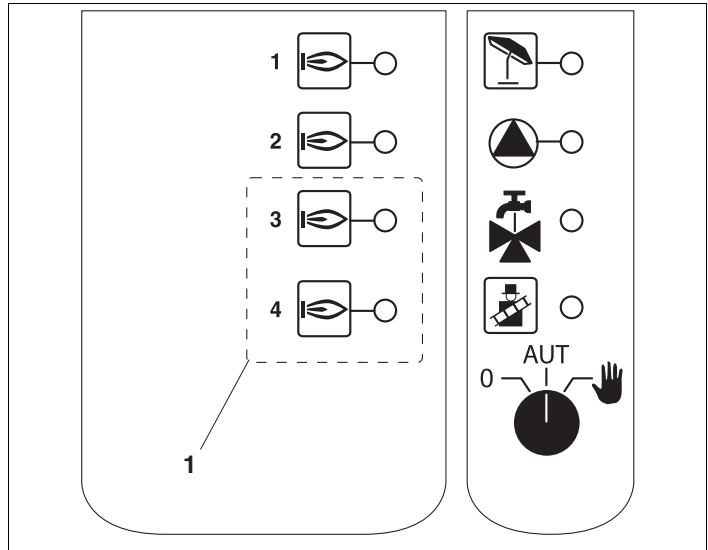

Fig. 1 Front panel – FM456/FM457 function module

1 only for FM457

Display	
	General fault, e.g. on-site faults, sensor faults, external faults, wiring faults, internal module faults, manual mode. The fault messages appear as plain text on the MEC2 remote control.

LEDs for the following functions:

Display	
	Burner on
	Unmixed heating zone in summer mode
	Heating pump in operation
	DHW via boiler 1 enabled
	Boiler in flue gas test activated

Collective fault output:

All control panel faults cause a switching of this output. Via the dry contacts of this output, for example, it is possible to switch on a light.

The manual switches on the modules only have service and maintenance functions, and affect only the 120 V outputs.

If the manual switches are not set to automatic, a message to this effect appears on the MEC2 remote control and fault indicator  illuminates.



USER NOTE

Never use the manual switches to shut down the heating system during temporary absence.

Use the vacation function for this purpose (see operating instructions for Logamatic 4323 control panel).

The control functions continue to operate in manual mode.

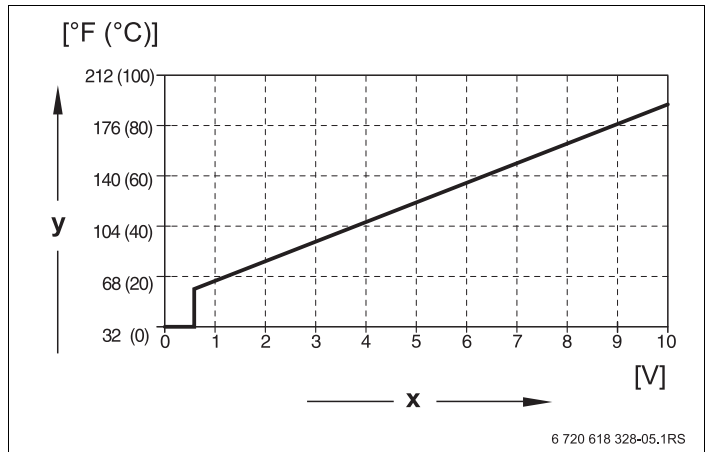

Fig. 2 0 – 10 V input

- x** Input voltage in V (factory setting)
- y** Set point boiler temperature in °F (°C)

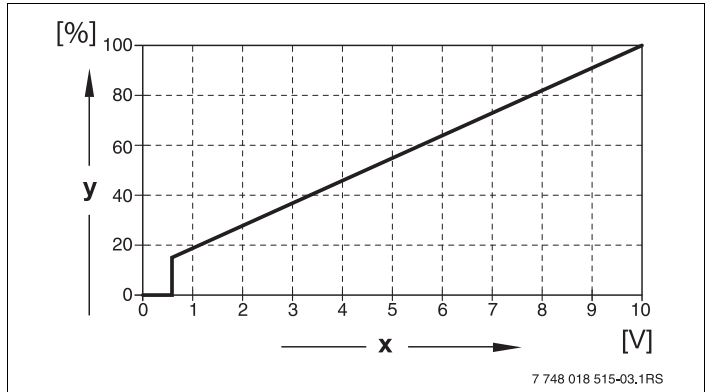

Fig. 3 0 – 10 V input

x Input voltage in V (factory setting)

y Output demand in %

Hook switches



USER NOTE

The hook switch must be open in connection with EMS.

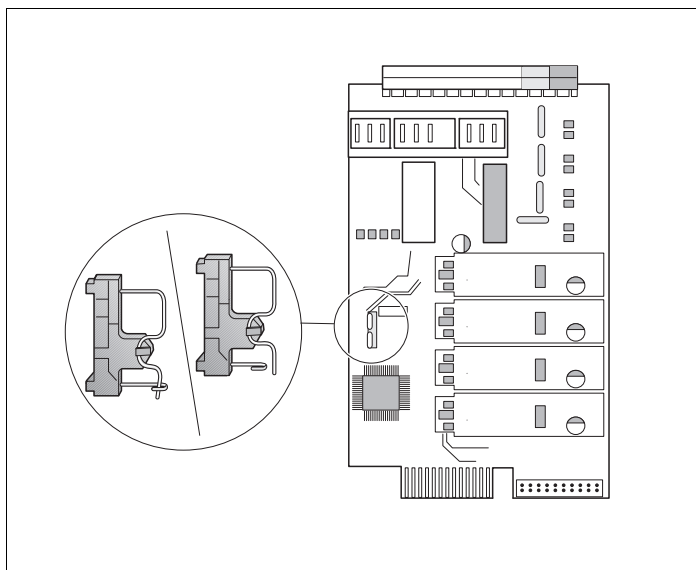
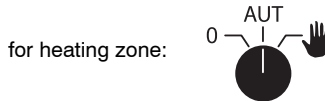

Fig. 4 Jumper switch (e.g. FM457)

Heating zone function

Manual heating zone switch



USER NOTE

Under normal circumstances, the manual switch should be set to "AUT".

The **0** and **manual operation** (hand icon) positions are special settings that should only be made by technicians.

: The heating pump is switched on.

AUT: The heating zone is operating in automatic mode.

0: The heating pump is switched off. The control functions continue to operate.

Current functions are indicated by LEDs.

3 Installation

3.1 Scope of delivery

- Check that all package contents are present.

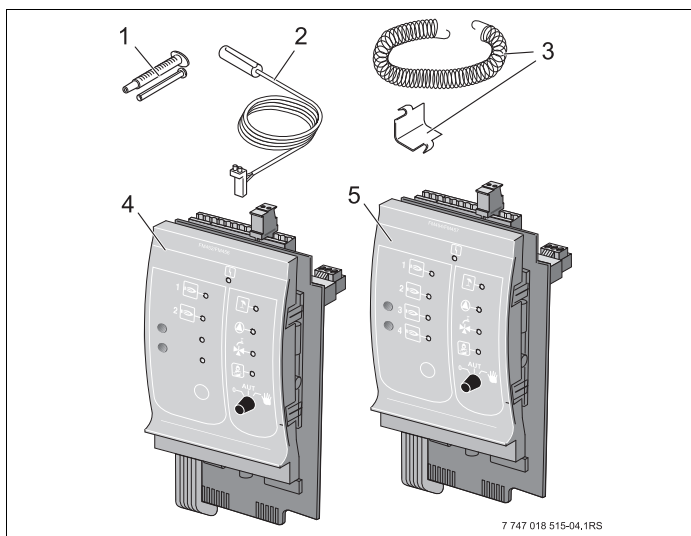

Fig. 5 Minimum delivery FM456/FM457¹⁾

- 1 Heat conducting paste
- 2 0.35 inch (9 mm) sensor as contact sensor²⁾
- 3 Fasteners for 0.35 inch (9 mm) sensor
- 4 FM456 function module
- 5 FM457 function module

1) May include additional components

2) Subject to the installation situation, the sensors can be used for the sensor connections listed in Tab. 3, page 17. The curves are identical.

Not shown operating instructions, service instructions, wiring diagram

3.2 Checking the software versions

The software versions of the CM431 controller module and the MEC2 remote control must be version 6.xx or higher.

- Before installing the FM456/FM457 function module, check the software versions of the CM431 controller module and the MEC2 remote control at the service level (version 6.xx or higher). For more information contact your Buderus wholesaler.

3.3 Installation in the Logamatic 4323 control panel

Generally, you can install the FM456/FM457 function modules into any vacant slot in the Logamatic 4323 control panel.



USER NOTE

Recommendation: Install the FM456/FM457 function module **as far to the right** as possible. This ensures that the heating zones are in a logical order. The heating zone modules should be installed in the control starting from the left side (slot 1).

Exceptions: Certain function modules must be installed in designated slots (e.g. FM446 in slot 4, if present → consult the documentation for the function modules).

This module can only be installed in the master with address 0 or 1.

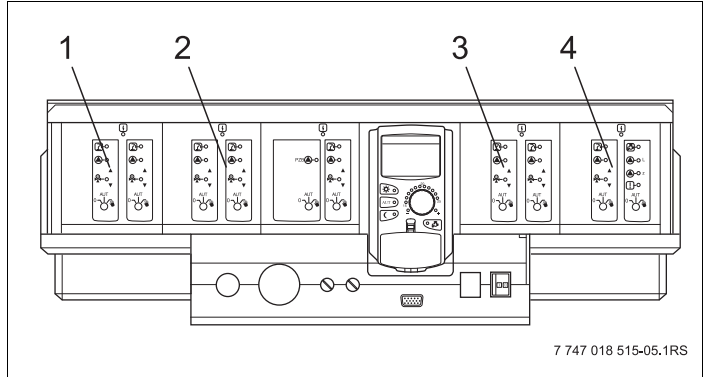

Fig. 6 Assignment of slots 1 – 4 (example: Logamatic 4323)

- 1 Slot 1, e.g. FM442 (heating zone 1, heating zone 2)
- 2 Slot 2, e.g. FM442 (heating zone 3, heating zone 4)
- 3 Slot 3, e.g. FM441 (heating zone 5, DHW/recirculation pump)
- 4 Slot 4, e.g. FM456/FM457 (multi-boiler control)

3.4 Connecting inputs and outputs

The low voltage sensor terminals and the 120 V outputs are available at the rear top of the FM456/FM457 function module. Colored labels with inscriptions matching the appropriate plugs are attached to the strips. Plugs are color-coded.

- Connect inputs and outputs correctly.

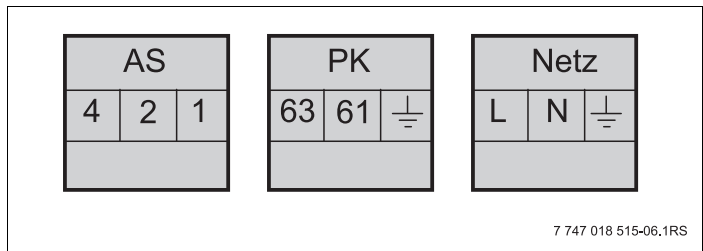

Fig. 7 Inputs and outputs

Designation	Description
AS	Output central fault message, dry contact min. switching capacity 12 V/20 mA max. switching capacity 120 V/5 A

Tab. 2 Inputs and outputs (terminal designation)

3.5 Connecting sensors

The sensor connections are located at the rear top of the FM456/FM457 function module. Colored labels with inscriptions matching the appropriate plugs are attached to the strips. Plugs are color-coded.

Sensor designation key

	Designation	Function
FA	Outdoor sensor (Fühler Außen)	This sensor determines the outdoor temperature and makes it available to the control panel.
FK	Boiler sensor (differential sensor) (Fühler Kessel (Weichenfühler))	This sensor is used to control a multi-boiler system. It is located at the heat transfer point from the boiler to the system (system supply).
U in 1/2	Voltage input 0 – 10 V	This input allows running the system with external input, dependent either on supply temperature or output; the system supply sensor acts as a reference point.

Tab. 3 Sensor connections



USER NOTE

Ensure that you connect the sensors correctly and mount them in the correct positions.

**USER NOTE**

When using two FM456/FM457 modules, connect the temperature sensors, the heat meter sensor or external boiler sequence changeover and the external load limit to that module which is connected to boiler 1. If voltage inputs are connected to each module as the default set temperature, the highest temperature will be used as the set value for the strategy. The voltage and fault message outputs are identical for both modules.

3.6 Connecting EMS boilers

The connections for connecting EMS boilers are at the rear top of the FM456/FM457 function modules. Colored labels with inscriptions matching the appropriate plugs are attached to the strips.

EMS/UBA 1		EMS/UBA 2		EMS/UBA 3 (only FM457)		EMS/UBA 4 (only FM457)	
2	1	2	1	2	1	2	1

EMS/UBA 1 interface to EMS boiler 1

... ..

EMS/UBA 4 interface to EMS boiler 4

If a second FM456/FM457 is installed, terminal EMS 1 on the r.h. (2nd) FM456/FM457 is assigned to boiler 5, terminal EMS 2 to boiler 6, terminal EMS 3 to boiler 7 and terminal EMS 4 to boiler 8.

4 Burner control and basic operation

Buderus wall-mounted boilers are equipped with a universal burner automation UBA 3/UBA 3.5.

Wall-mounted boilers with UBA 3/UBA 3.5 are operated just like floorstanding boilers with EMS (energy management system) via the BC10 basic controller.

If it is necessary to distinguish cases below, the designations in Tab. 4 will be used.

There is a listing of the individual boiler types on page 22.

	Wall-mounted boiler with EMS		Floorstanding boilers with EMS
Burner control	UBA 3	UBA 3.5	SAFe EMS automatic ignition controller
Basic operation	BC10 basic controller		
Identification	"EMS/UBA 3"	"EMS/UBA 3.5"	"EMS/SAFe"

Tab. 4 Identification of the boiler types

4.1 BC10 base controller (EMS)

The BC10 base controller enables the standard operation of boilers with EMS/UBA 3 or EMS/SAFe.



USER NOTE

Extended functions are set via the MEC2 remote control.

Both dials must be set to "Aut" (otherwise a fault message will be issued).

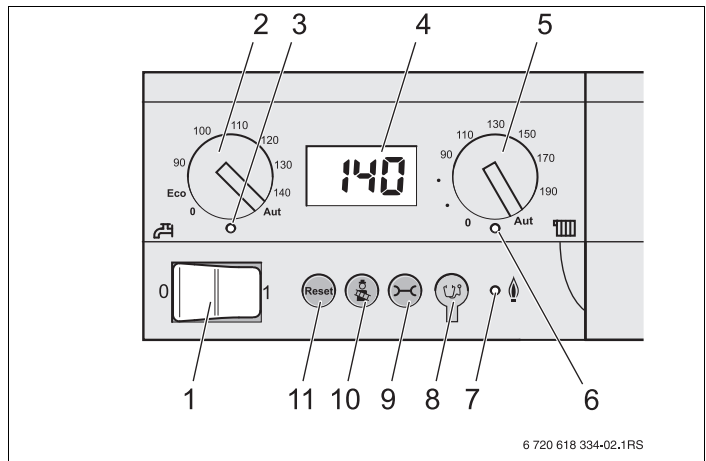



Fig. 8 BC10 controls

- 1 On/Off switch
- 2 Dial for DHW set point
- 3 LED "DHW status"
- 4 Status display screen
- 5 Dial for maximum boiler temperature in heating mode
- 6 "Heat demand" LED
- 7 "Burner" LED (On/Off)
- 8 Diagnostic plug
- 9 "Status display" button
- 10 "Flue gas test" button
- 11 "Reset" button

Setting an output restriction

The boiler output can be restricted to 37.5 kBTU/hr (11 kW) (or 170.6 kBTU/hr (50 kW) on higher output boilers) using a jumper on the back of the base controller.

- Remove the base controller.
- Remove jumper [1] if the boiler output is to be restricted.

Jumper	State	Explanation
	Not inserted	Output restricted to 37.5 kBTU/hr (11 kW) (170.6 kBTU/hr (50 kW)) (only for boilers with UBA 3)
	Inserted	Output not restricted (state of device when delivered)

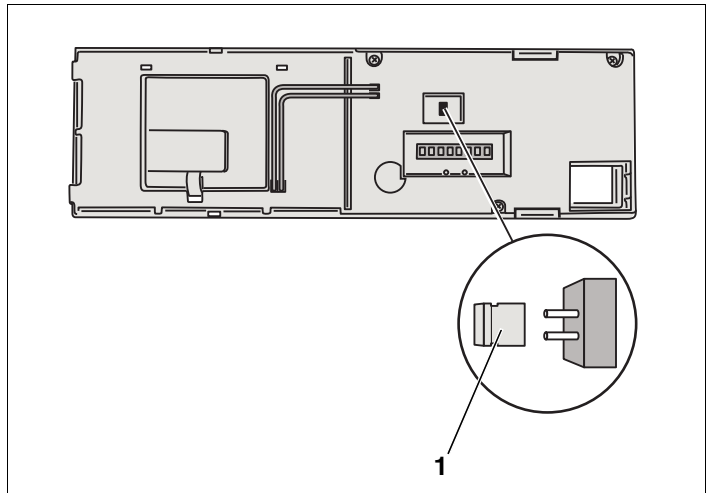

Fig. 9 Back of the BC10 base controller

1 Jumper for restricting output

4.2 Approved boiler types

Type	BCM no.	Designation of the boiler
EMS/UBA 3	1000	Logamax plus GB142-30
	1002	Logamax plus GB142-24
	1015	Logamax plus GB142-45
	1016	Logamax plus GB142-60
	1026	Logamax plus GB162-100
	1027	Logamax plus GB162-80

Tab. 5 Approved boiler types EMS/UBA 3

Type	BCM no.	Designation of the boiler
EMS/UBA 3.5	1072	Logamax plus GB162-15
	1073	Logamax plus GB162-25
	1074	Logamax plus GB162-35
	1075	Logamax plus GB162-45

Tab. 6 Approved boiler types EMS/UBA 3.5

Type EMS/SAFe	BIM no.	Designation of the boiler
SAFe 40	6032	Logano plus GB312-120
SAFe 40	6033	Logano plus GB312-160
SAFe 40	6034	Logano plus GB312-200
SAFe 40	6035	Logano plus GB312-240
SAFe 40	6036	Logano plus GB312-280
SAFe 40	6037	Logano plus GB312-90

Tab. 7 Approved boiler types EMS/SAFe

5 General data

5.1 0 – 10 V input

As soon as a module with 0 – 10 V input has been installed in the control panel, the following screens appear as listed in the table below:

Module	Name	Temperature control	Power control
FM447	Strategy module	X	
FM448	Fault module	X	
FM456	KSE 2 (EMS)	X	X (CM431 V6.xx or higher)
FM457	KSE 4 (EMS)	X	X (CM431 V6.xx or higher)
FM458	Mixed cascade	X	X (CM431 V8.xx or higher)
ZM433	Sub station	X	



Call up the service level. "general specs" appears as the first main menu.



Press "Display" to call up a submenu (here: "min outdoor temp").

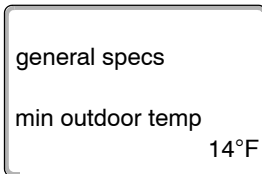

The display shows the selected submenu.



Turn the dial until the submenu "0 – 10 V input" appears.

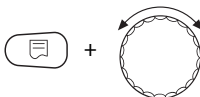

Hold down "Display" and turn the dial until the desired set value appears (here: "temp.control").

general specs

0-10V input

temp.control

The display shows the set value.

Release "Display" to save your settings.

	Input range	Factory setting
0-10V input	OFF temp.control power control	temp.control

5.2 Temperature/output control 0 – 10 V input

If you have selected "temp.control" for a 0 – 10 V input, you can set the start and end points, if required, for the external 0 – 10 V input.

You can set the following:

- The set point in °F (°C) for 0 V ("temp.control 0V corresp. to")
- The set point in °F (°C) for 10 V ("temp.control 10V corresp. to")

The following linear curve is calculated from these values:

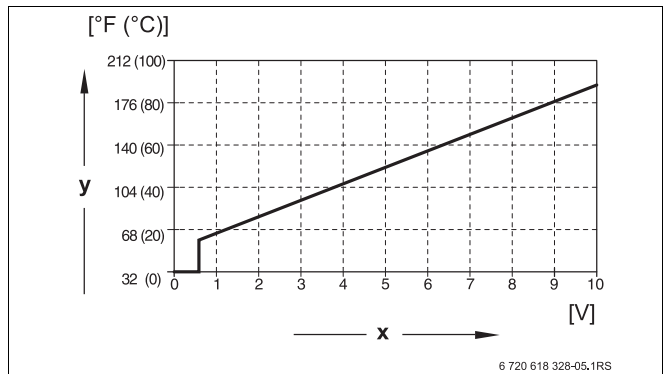

Fig. 10 0 – 10 V input

x Input voltage in V (factory setting)

y Set point boiler temperature in °F (°C)

The start value (start point) of the curve is set to 0.6 V for a positive curve; Fig 10 shows the factory setting.



Call up the service level. "general specs" appears as the first main menu.



Press "Display" to call up a submenu (here: "min outdoor temp").

general specs

min outdoor temp

14°F

The display shows the selected submenu.



Turn the dial until submenu "temp.control 0V corresp. to" or "temp.control 10V corresp. to" appears.



+



Hold down "Display" and turn the dial until the desired set value appears (here: "41°F" (5°C)).

general specs

temp.control

0V corresp. to

41°F

The display shows the set value.

Release "Display" to save your settings.



Press "Back" to return to the next level up.



Turn the dial until submenu "temp.control 10V corresp. to" appears.



+



Hold down "Display" and turn the dial until the desired set value appears (here: "194°F" (90°C)).

general specs
temp.control
10V corresp. to
194°F

The display shows the set value.

Release "Display" to save your settings.

	Input range	Factory setting
temp.control 0V	off 41 °F – 210 °F (5 °C – 99 °C)	off
temp.control 10V	41 °F – 210 °F (5 °C – 99 °C)	194 °F (90 °C)



USER NOTE

If a curve with a negative incline is programmed, e.g. 0 volt = 194 °F (90 °C), ensure that all 0 – 10 V inputs of a control panel are functioning. An open input corresponds to 0 V and thus a to heat demand for, e.g. 194 °F (90 °C).

The demand should be set parallel at all inputs of a control if applicable.

5.3 Power control for 0 – 10 V input

In conjunction with modulating EMS boilers, the 0 – 10 V input can also be used for power control.



USER NOTE

The power control functions with a boiler or with a cascade of identical boilers (type and output).

If you have selected power control for the 0 – 10 V input, you can, if necessary, match the curve for external power control.

You can set the following:

- The set output value for 0 V ("power control 0V corresp. to")
- The set output value for 10 V ("power control 10V corresp. to")

The following linear curve is calculated from these values:

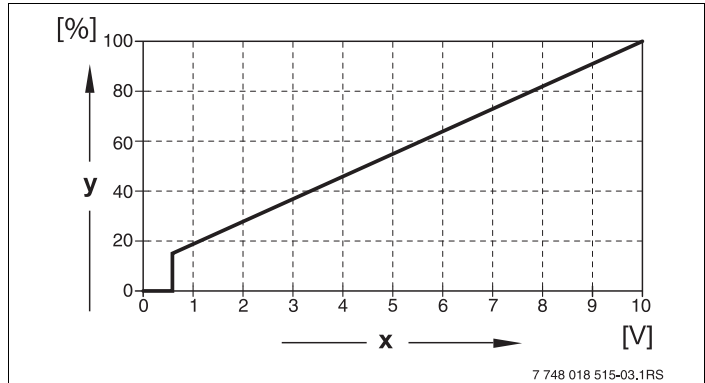

Fig. 11 0 – 10 V input

- x** Input voltage in V (factory setting)
- y** Output demand in %

The start value (switch-on point) of the curve is set to 0.6 V with a positive curve.



USER NOTE

In case of external power control, the control panels can no longer take internal heat demands into consideration, e.g. from heating zones or DHW function.



USER NOTE

If a curve with a negative incline is programmed, e.g. 0 volt = 100 % output, ensure that all 0 – 10 V inputs of this control panel are functional. An open input corresponds to 0 V and thus to an output demand of 100 %.

The demand should be set parallel at all 0 – 10 V inputs of a control panel, if applicable.

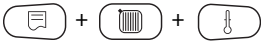

Call up the service level. "general specs" appears as the first main menu.



Turn the dial until the main menu "boiler specs" appears.



Press "Display" to call up a submenu (here: "No of boilers").



Turn the dial until submenu "power control" appears.

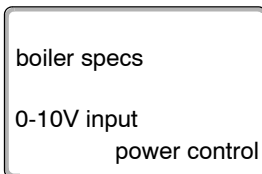

The display shows the selected submenu.

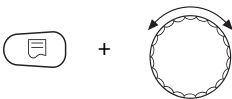

Hold down "Display" and turn the dial until the desired value appears (here: "0V corresp. to 0%").

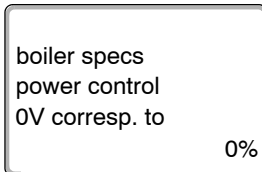

Press "Back" to return to the next level up. The selected value flashes on the display.

Release "Display" to save your settings.



Turn the dial until the submenu "10V corresp. to ...%" appears.

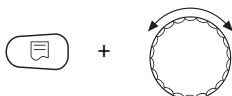

Hold down "Display" and turn the dial until the desired value appears (here: "10V corresp. to 100%").

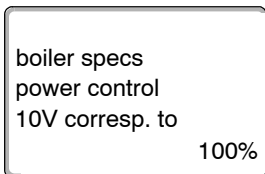

Press "Back" to return to the next level up. The selected value flashes on the display.

Release "Display" to save your settings.



Press "Back" to return to the next level up.

	Input range	Factory setting
power control 0V	0 % – 100 %	0 %
power control 10V	0 % – 100 %	100 %

6 Boiler data

If there is a multi-boiler module in the control panel, e.g. KSE module FM456 or FM457, you can set the boiler data in this menu.

6.1 Number of boilers

With this function, you can set the number of boilers according to the module selection.

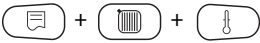

Call up the service level. "general specs" appears as the first main menu.



Turn the dial until the main menu "boiler specs" appears.



Press "Display" to call up a submenu (here: "No of boilers").

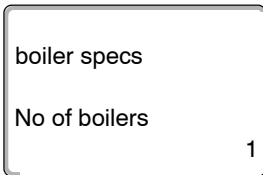

The display shows the selected submenu.

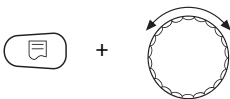

Hold down "Display" and turn the dial until the desired value appears (here: "4").

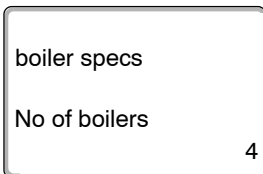

Press "Back" to return to the next level up. The selected value flashes on the display.

Release "Display" to save your settings.



Press "Back" to return to the next level up.



USER NOTE

A maximum number of 8 boilers can be set if two FM457 multi-boiler modules are used in a control panel. If the number boilers is set to 0, the control panel runs as a slave unit.

	Input range	Factory setting
No of boilers (depending on the module selection)	0 – 8	1

6.2 Hydraulics (for single-boiler system)

You can use this function if the **number of boilers is 1**. You can choose whether the boiler's hydraulics should work with or without boiler pump and low loss header.

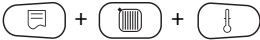

Call up the service level. "general. specs" appears as the first main menu.



Turn the dial until the main menu "boiler specs" appears.



Press "Display" to call up a submenu (here: "No of boilers").

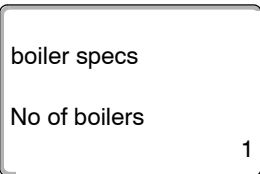

The display shows the selected submenu.



Turn the dial until submenu "hydraulic" appears.

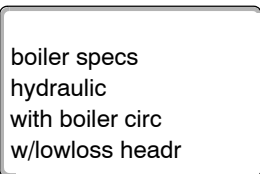

The display shows the selected submenu.

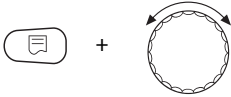

Hold down "Display" and turn the dial until the desired value appears (here: "with boiler circ/no lowloss headr").

boiler specs
hydraulic
with boiler circ
no lowloss headr

Press "Back" to return to the next level up. The selected value flashes on the display.

Release "Display" to save your settings.



Press "Back" to return to the next level up.

	Input range		Factory setting	Own setting
Hydraulic scheme	with boiler circ/ w/lowloss headr		with boiler circ/ w/lowloss headr	
	with boiler circ/ no lowloss headr			
	no boiler circ no lowloss headr			

Tab. 8 Hydraulic scheme

1 HZ1

2 HZ2

6.3 Hydraulics (for multi-boiler systems)

In connection with modulating EMS boilers, the hydraulic incorporation for multi-boiler cascades can be set.

Call up the service level. "general specs" appears as the first main menu.

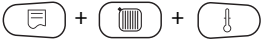

Turn the dial until the main menu "boiler specs" appears.



Press "Display" to call up a submenu (here: "No of boilers").



The "No of boilers" must be set greater than 1 (here: "4").

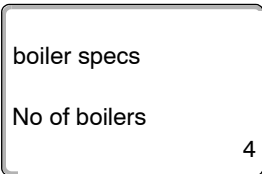

Turn the dial until submenu "hydraulic" appears.



The display shows the selected submenu.

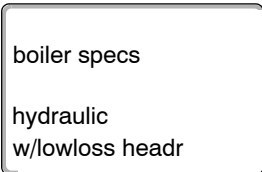

Hold down "Display" and turn the dial until the desired value appears (here: "Butterfly valve")

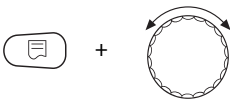

Press "Back" to return to the next level up. The selected value flashes on the display.

Release "Display" to save your settings.

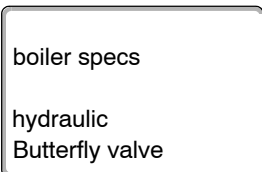



Press "Back" to return to the next level up.

	Input range	Factory setting
hydraulic (multi-boiler system)	w/lowloss headr Butterfly valve	w/lowloss headr



USER NOTE

The selection "Butterfly valve" may only be selected in connection with the Logano GB312.

The butterfly valve flaps are controlled by the optional DM10 EMS module in each EMS boiler.

6.4 Detection of auxiliary heat

With this function, you can set the temperature difference for the low loss header starting with which the auxiliary heat is detected. This function is only activated for single-boiler systems.



Call up the service level. "general specs" appears as the first main menu.



Turn the dial until the main menu "boiler specs" appears.



Press "Display" to call up a submenu (here: "No of boilers").

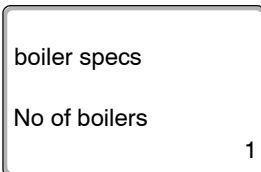

The display shows the selected submenu.



Turn the dial to call up submenu "recognition aux. heat at".

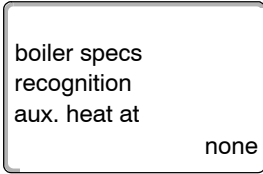

The display shows the selected submenu.

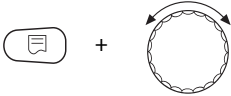

Hold down "Display" and turn the dial until the desired value appears (here: "63°F" (17°C)).

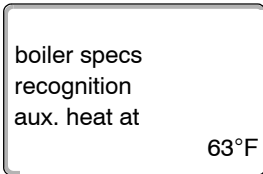

Press "Back" to return to the next level up. The selected value flashes on the display.

Release "Display" to save your settings.



Press "Back" to return to the next level up.

Example:

With a setting of 50 °F (10 °C), the boiler(s) switch off as soon as the actual temperature is 50 °F (10 °C) above the set supply temperature.

	Input range	Factory setting
temperature	none	
aux. heat recognition	41 °F – 68 °F (5 °C – 20 °C)	none

6.5 Boiler type

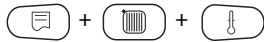

With this function, you can choose between different boiler types.

Call up the service level. "general specs" appears as the first main menu.



Turn the dial until the main menu "boiler specs" appears.



Press "Display" to call up a submenu (here: "No of boilers").

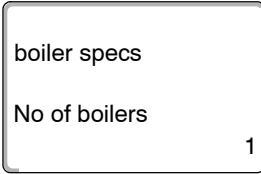

The display shows the selected submenu.



Turn the dial until submenu "boiler type" appears.

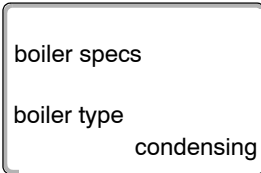

The display shows the selected submenu.

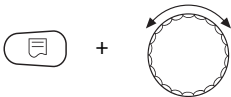

Hold down "Display" and turn the dial until the desired value appears (here: "low temperature").

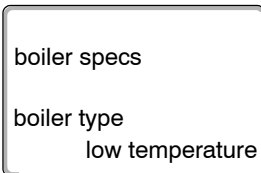

Press "Back" to return to the next level up. The selected value flashes on the display.

Release "Display" to save your settings.



Press "Back" to return to the next level up.



USER NOTE

In a multi-boiler system, the setting "low temperature" must be selected as soon as a non-condensing boiler is installed.

	Input range	Factory setting
boiler type	condensing low temperature	condensing

6.6 Limiting boiler output

You can only use this function if the **number of boilers is 1**. You can set the maximum output of the boiler as a percentage of the nominal output.

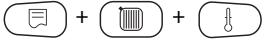

Call up the service level. "general specs" appears as the first main menu.



Turn the dial until the main menu "boiler specs" appears.



Press "Display" to call up a submenu (here: "No of boilers").

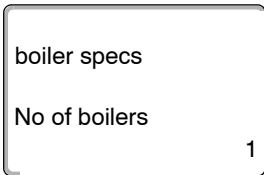

The display shows the selected submenu.

To change the boiler output, this setting "No of boilers 1" must be retained.



Turn the dial until submenu "boiler output" appears.

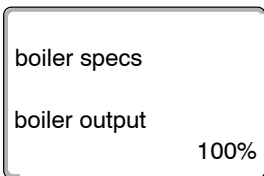

The display shows the selected submenu.



+



Hold down "Display" and turn the dial until the desired value appears (here: "80%").

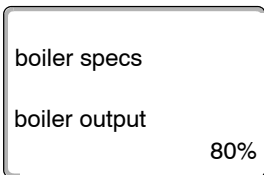

Press "Back" to return to the next level up. The selected value flashes on the display.

Release "Display" to save your settings.



Press "Back" to return to the next level up.

	Input range	Factory setting
boiler output	50 % – 100 %	100 %

6.7 Maximum boiler temperature

With this function, you can set the maximum boiler temperature.

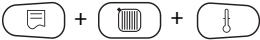

Call up the service level. "general specs" appears as the first main menu.



Turn the dial until the main menu "boiler specs" appears.



Press "Display" to call up a submenu (here: "No of boilers").

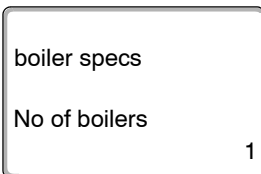

The display shows the selected submenu.



Turn the dial until "maximum boiler temp" appears.

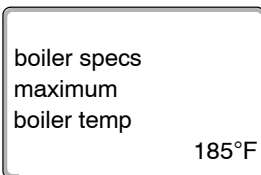

The display shows the selected submenu.

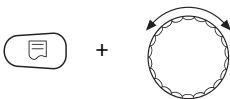

Hold down "Display" and turn the dial until the desired value appears (here: "158°F" (70°C)).

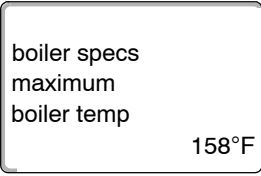

The selected value flashes on the display.
Release "Display" to save your settings.



Press "Back" to return to the next level up.

	Input range	Factory setting
maximum boiler temp	122 °F – 194 °F (50 °C – 90 °C)	185 °F (85 °C)

6.8 Setting the type of sequence control

You can use this function if the **number of boilers is at least 2**.
With this function, you can set the type of sequence control.

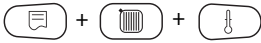

Call up the service level. "general specs" appears as the first main menu.



Turn the dial until the main menu "boiler specs" appears.



Press "Display" to call up a submenu (here: "No of boilers").

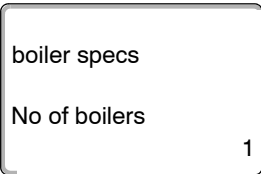

The display shows the selected submenu.

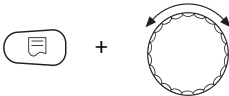

Hold down "Display" and, with the dial, increase the number of boilers at least to 2.

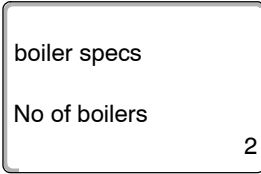

The display shows the selected submenu.

Release "Display" to save your settings.



Turn the dial until submenu "sequence control" appears.

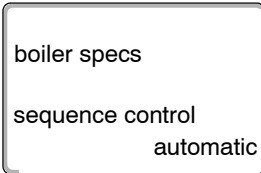

The display shows the selected submenu.

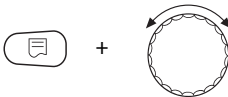

Hold down "Display" and turn the dial until the desired value appears (here: "set").

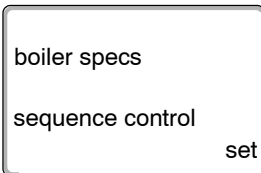

The selected value flashes on the display.

Release "Display" to save your settings.



Press "Back" to return to the next level up.

	Input range	Factory setting
sequence control	automatic set	automatic

Sequence control

With the setting "set", the boilers will be switched in this sequence:

1 — 2 — 3 — 4

Boiler 1 is always switched on first, then boiler 2, etc.

With the setting "automatic", the lead boiler will be determined depending on the date.

On the 1st of the month: 1 — 2 — 3 — 4

On the 2nd of the month: 2 — 3 — 4 — 1

On the 3rd of the month: 3 — 4 — 1 — 2

On the 4th of the month: 4 — 1 — 2 — 3

On the 5th of the month: 1 — 2 — 3 — 4

etc.



USER NOTE

If you have selected the settings "UBA tankless htr", "EMS tankless htr", "UBA tank" or "EMS 3-way valve", boiler 1 will always appear as the last in the sequence.

On the 1st of the month: 2 — 3 — 4 — 1

On the 2nd of the month: 3 — 4 — 2 — 1

On the 3rd of the month: 4 — 2 — 3 — 1

On the 4th of the month: 2 — 3 — 4 — 1

etc.

7 DHW data

The DHW function is part of the basic equipment of the control panel used.



USER NOTE

Water will be heated exclusively via the Logamatic 4000 – DHW module (e.g. FM441) if one is installed.

In this case, the DHW settings described in this chapter will not apply. For applicable settings see the documentation of the corresponding module/control panel.

7.1 Selecting the DHW storage tank

Here, you can enable and disable the DHW storage tank. If a cascade module is installed, you can select the type of water connections for the DHW storage tank.

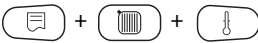

Call up the service level. "general data" appears as the first main menu.



Turn the dial until main menu "DHW" appears.

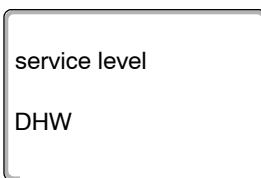

The display shows main menu "DHW".



Press "Display" to call up a submenu (here: "DHW").

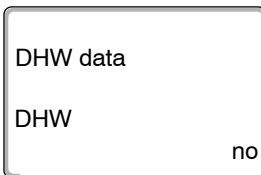

The automatically-recognized DHW storage tank will be preset on the display.

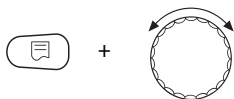

Hold down "Display" and turn the dial until the required value appears (here: "EMS 3-way valve").

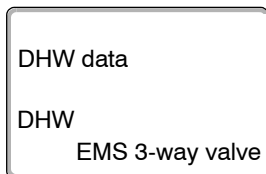

The display shows the set value.

Release "Display" to save your settings.



Press "Back" to return to the next level up.

	Input range	Factory setting
DHW	no EMS 3-way valve EMS circulator EMS tankless htr	automatically-recognized factory default in online mode

Parameter	EMS 3-way valve	EMS circulator	EMS tankless htr
Set temperature range	X	X	X
Selecting switching optimization	X	X	
Selecting leftover heat use	X	X	
Setting differential	X	X	
Thermal disinfection*	X	X	
Daily heating*	X	X	X
Recirculation pump*	X	X	

Tab. 9 Possible parameters, subject to hydraulic connection

* with subsequent settings

7.2 Set temperature range

With this function you can set the upper limit for the desired DHW temperature.



WARNING!

RISK OF SCALDING

from DHW.

There is a risk of scalding if the desired DHW temperature is set higher than 122 °F (50 °C).

- Do not draw off DHW unmixed.



Call up the service level. "general data" appears as the first main menu.



Turn the dial until main menu "DHW" appears.



Press "Display" to call up a submenu (here: "DHW").

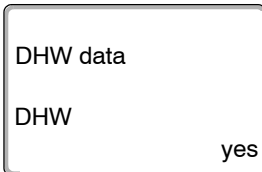

The display shows the selected submenu.



Turn the dial until submenu "range to" appears.

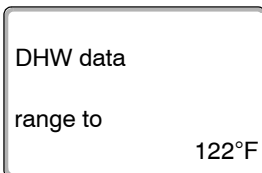

The display shows the selected submenu.

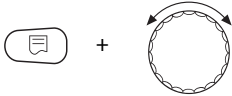

Hold down "Display" and turn the dial until the desired value appears (here: "176°F" (80°C)).

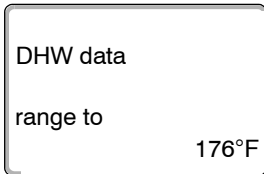

Press "Back" to return to the next level up. The selected value flashes on the display.

Release "Display" to save your settings.



Press "Back" to return to the next level up.

	Input range	Factory setting
range to	122 °F – 176 °F (50 °C – 80 °C)	122 °F (50 °C)

7.3 Selecting switching optimization

If you select the "optimization" function, DHW heating will begin prior to the actual start point. The control panel calculates the timing of the start, taking into consideration the residual storage tank heat and the start of the heating for the heating zones, so that the DHW temperature is reached in good time.



Call up the service level. "general data" appears as the first main menu.



Turn the dial until main menu "DHW" appears.



Press "Display" to call up a submenu (here: "DHW").

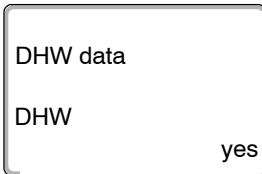

The display shows the selected submenu.



Turn the dial until submenu "optimization start optimiz." appears.

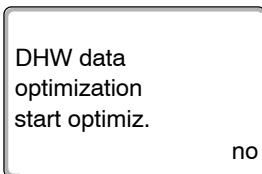

The display shows the selected submenu.

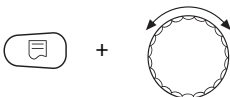

Hold down "Display" and turn the dial until the desired value appears (here: "yes").

DHW data
optimization
start optimiz.

yes

The display shows the set value.

Release "Display" to save your settings.



Press "Back" to return to the next level up.

	Input range	Factory setting
optimization	yes no	no

7.4 Selecting leftover heat use

If you select the "utlz.leftovr.ht" function, you can also utilize the residual boiler heat for heating the storage tank.

"Leftover heat use yes"

If you select "utlz.leftovr.ht yes", the control panel calculates the shutdown temperature of the burner and the runtime of the primary pump via the leftover boiler heat, until the cylinder is fully heated. The burner is switched off before the set DHW temperature is reached. The tank heating pump continues to operate. The control panel calculates the runtime of the primary pump (between 3 and 30 minutes) to heat the storage tank.

"Leftover heat use no"

If you select "utlz.leftovr.ht no", you will only use a small amount of leftover heat. The burner runs until the desired DHW temperature has been reached. The storage tank primary pump runs on for 3 minutes after the burner has been switched off.



Call up the service level. "general data" appears as the first main menu.



Turn the dial until main menu "DHW" appears.



Press "Display" to call up a submenu (here: "DHW").

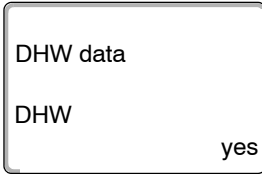

The display shows the selected submenu.



Turn the dial until submenu "utlz.leftovr.ht" appears.

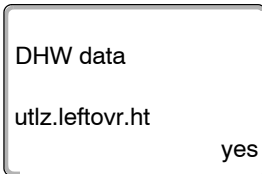

The display shows the selected submenu.



+



Hold down "Display" and turn the dial until the desired value appears (here: "no").

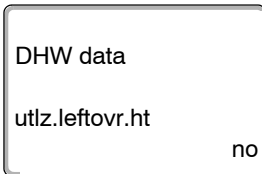

Press "Back" to return to the next level up. The selected value flashes on the display.

Release "Display" to save your settings.



Press "Back" to return to the next level up.

	Input range	Factory setting
utlz.leftovr.ht	yes no	yes

7.5 Setting differential

With "differential" you can determine at how many degrees Fahrenheit (°F) below the set DHW temperature the reloading of the storage tank begins.

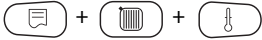

Call up the service level. "general data" appears as the first main menu.



Turn the dial until main menu "DHW" appears.



Press "Display" to call up a submenu (here: "DHW").

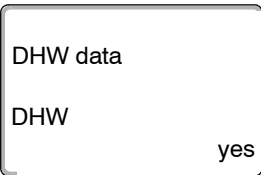

The display shows the selected submenu.



Turn the dial until submenu "differential" appears.

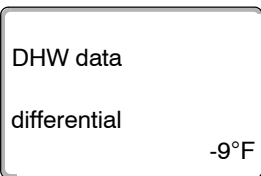

The display shows the selected submenu.

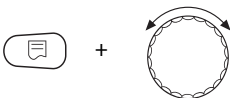

Hold down "Display" and turn the dial until the desired value appears (here: "-36°F" (-20°C)).

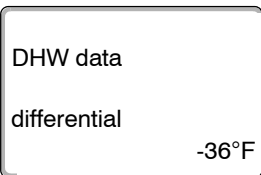

Press "Back" to return to the next level up. The selected value flashes on the display.

Release "Display" to save your settings.



Press "Back" to return to the next level up.

	Input range	Factory setting
differential	-36° F – 4° F (-20 °C – 2 °C)	-9° F (-5 °C)

7.6 Selecting and setting thermal disinfection

If you select the "thermal disinfection" function, the DHW is brought to a temperature (158 °F (70 °C)) once or several times a week. This is high enough to kill off germs (e.g. legionella bacteria).

The tank primary pump and DHW recirculation pump run constantly during the thermal disinfection process.

If you have selected "thermal disinfection yes", thermal disinfection starts according to factory settings or your own preferences.

Thermal disinfection is indicated by the LED  on the FM441 module.

You can adjust the factory settings for thermal disinfection via additional menus.

The system tries to reach the set thermal disinfection temperature for three hours. If this fails, the error message "thermal disinfection failed" appears.

You may also set up thermal disinfection via your own switching program.



Call up the service level. "general data" appears as the first main menu.



Turn the dial until main menu "DHW" appears.



Press "Display" to call up a submenu (here: "DHW").

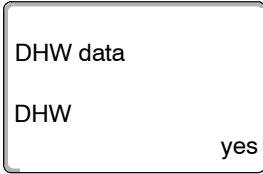

The display shows the selected submenu.



Turn the dial until "thermal disinfection" appears.

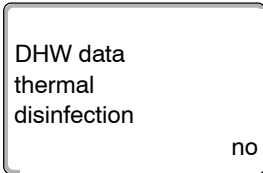

The display shows the selected submenu.



+



Hold down "Display" and turn the dial until the desired value appears (here: "yes").

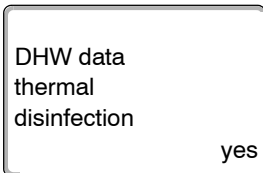

The display shows the set value.

Release "Display" to save your settings.



Press "Back" to return to the next level up.

	Input range	Factory setting
thermal disinfection	no yes	no

7.7 Setting disinfection temperature

The disinfection temperature can be set with the "temperature disinfection" function.



WARNING!

RISK OF SCALDING

from DHW.

- If thermal disinfection is activated, ensure that a thermostatic tempering valve is installed as protection against scalding.

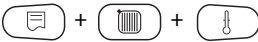

Call up the service level. "general data" appears as the first main menu.

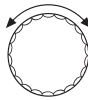

Turn the dial until main menu "DHW" appears.



Press "Display" to call up a submenu (here: "DHW").

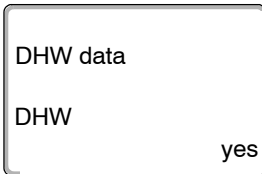

The display shows the selected submenu.



Turn the dial until submenu "temperature disinfection" appears.

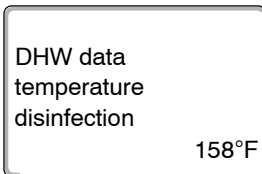

The display shows the selected submenu.

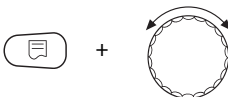

Hold down "Display" and turn the dial until the desired value appears (here: "167°F" (75°C)).

DHW data
temperature
disinfection

167°F

Press "Back" to return to the next level up. The selected value flashes on the display.

Release "Display" to save your settings.



Press "Back" to return to the next level up.

	Input range	Factory setting
temperature disinfection	149 °F – 167 °F (65 °C – 75 °C)	158 °F (70 °C)

7.8 Setting day of week for disinfection

The day of the week for disinfection can be set with the "day of week disinfection" function.



Call up the service level. "general data" appears as the first main menu.



Turn the dial until main menu "DHW" appears.



Press "Display" to call up a submenu (here: "DHW").

DHW data
DHW

yes

The display shows the selected submenu.



Turn the dial until submenu "day of week disinfection" appears.

DHW data
day of week
disinfection

Tuesday

The display shows the selected submenu.

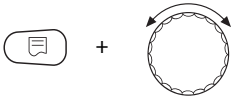

Hold down "Display" and turn the dial until the desired value appears (here: "Sunday").

DHW data
day of week
disinfection

Sunday

The display shows the set value.

Release "Display" to save your settings.



Press "Back" to return to the next level up.

	Input range	Factory setting
day of week disinfection	Monday – Sunday daily	Tuesday

7.9 Setting time of day for disinfection

The time of day for disinfection can be set with the "time disinfection" function.

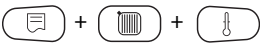

Call up the service level. "general data" appears as the first main menu.



Turn the dial until main menu "DHW" appears.



Press "Display" to call up a submenu (here: "DHW").

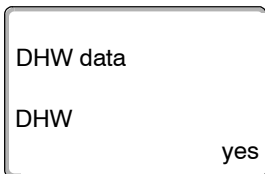

The display shows the selected submenu.



Turn the dial until submenu "time disinfection" appears.

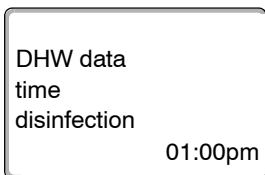

The display shows the selected submenu.

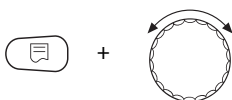

Hold down "Display" and turn the dial until the desired value appears (here: "06:00pm" (18:00)).

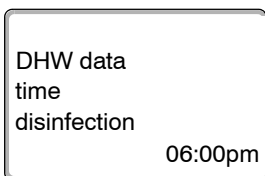

The display shows the set value.

Release "Display" to save your settings.



Press "Back" to return to the next level up.

	Input range	Factory setting
time disinfection	12:00 am – 11:00 pm (00:00 h – 23:00 h)	01:00 pm (01:00 h)

7.10 Daily heating

When daily heat-up is set, the DHW (which may include a solar storage tank, if installed) is heated to 140 °F (60 °C) once a day to prevent legionella bacteria from multiplying in the DHW.

The time when the storage tank is heated can be adjusted.

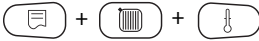

Call up the service level. "general data" appears as the first main menu.



Turn the dial until main menu "DHW" appears.



Press "Display" to call up a submenu (here: "DHW").

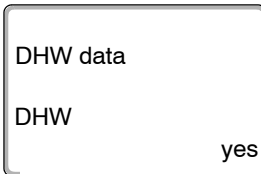

The display shows the selected submenu.



Turn the dial "daily heat up" appears.

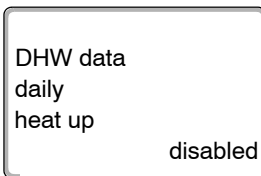

The display shows the selected submenu.

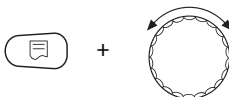

Hold down "Display" and turn the dial until the desired value appears (here: "06:00pm" (18:00)).

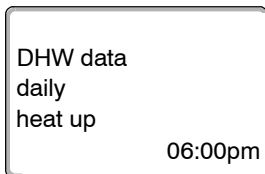

The display shows the set value.

Release "Display" to save your settings.



Press "Back" to return to the next level up.



USER NOTE

If the DHW was heated to 140 °F (60 °C) within the last 12 hours, it is not heated at the specified time.

	Input range	Factory setting
daily heat up	12:00 am – 11:00 pm (00:00 h – 23:00 h)	disabled

7.11 Selecting the recirculation pump

You can set DHW to be immediately available at the tap via the "recirculation" function.

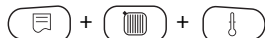

Call up the service level. "general data" appears as the first main menu.



Turn the dial until main menu "DHW" appears.



Press "Display" to call up a submenu (here: "DHW").

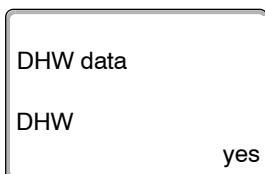

The display shows the selected submenu.



Turn the dial until submenu "recirculation" appears.

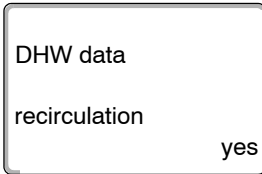

The display shows the selected submenu.



+



Hold down "Display" and turn the dial until the desired value appears (here: "no").

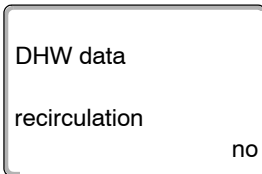

The display shows the set value.

Release "Display" to save your settings.



Press "Back" to return to the next level up.

	Input range	Factory setting
recirculation	yes no	yes

7.12 Setting the recirculation pump intervals

Interval operation reduces the operating costs of the recirculation pump.

You can set DHW to be immediately available at the draw-off points via the "recirculation per hour" function.

The set interval applies during that time in which the time program enables the DHW circulation pump. This may be:

- the factory-set recirculation pump program
- your own recirculation pump program
- a connection to the heating zone switching times

In constant mode the recirculation pump operates continuously when in day mode, and is switched off in night mode.

Example:

A time program was input, which during the period from

5:30 am – 10:00 pm (05:30 h – 22:00 h) switches the recirculation pump on with the setting "recirculation per hour 2 cycles".

The circulation pump is switched on

- at 5:30 am (05:30 h) for 3 minutes
- at 6:00 am (06:00 h) for 3 minutes
- at 6:30 am (06:30 h) for 3 minutes
- etc. until 10:00 pm (22:00 h).



Call up the service level. "general data" appears as the first main menu.



Turn the dial until main menu "DHW" appears.



Press "Display" to call up a submenu (here: "DHW").

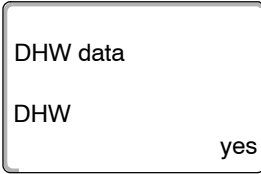

The display shows the selected submenu.



Turn the dial until submenu "recirculation per hour" appears.

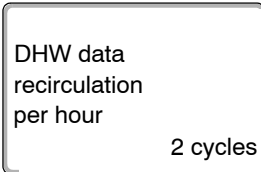

The display shows the selected submenu.

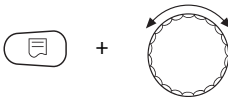

Hold down "Display" and turn the dial until the desired value appears (here: "off"). The recirculation pump will now only operate during heating once.

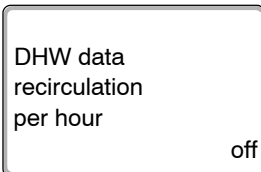

The display shows the set value.

Release "Display" to save your settings.



Press "Back" to return to the next level up.

	Input range	Factory setting
recirculation per hour	off 1 cycles 2 cycles 3 cycles 4 cycles 5 cycles 6 cycles constant oper.	2 cycles

8 Relay test

With the "relay test" menu, you can verify whether you have correctly connected the external components (e.g. pumps).

The displays depend on the installed modules. Depending on the current operating conditions, there may be a time delay between demand and display.



CAUTION!

RISK OF LIFE

through disabled functions.

The heat supply of the heating system is not assured during the relay test. All functions are disconnected from the control.

- Exit this function after the relay test to prevent system damage.

With the FM456/FM457 modules, you can call up the following relays:

Heating zone 1 – 7 (subject to slot)

- Circulator

DHW

- DHW loading
- Recirculation pump

KSE

- Fault relay

Relay test examples

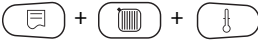

Call up the service level. "general data" appears as the first main menu.



Turn the dial until main menu "relay test" appears.

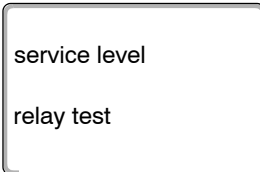

The display shows the selected main menu.



Press "Display" to call up a submenu (here: "heating zone 0").

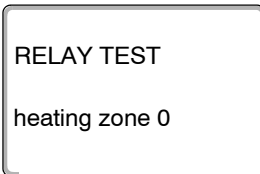

The display shows the selected submenu.



Turn the dial until submenu "heating zone 3" appears (KSE module in slot 2).

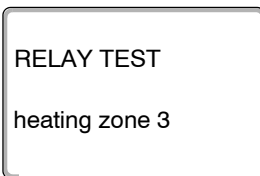

The display shows the selected submenu.



Press "Display" to call up another submenu (here: "circulator").

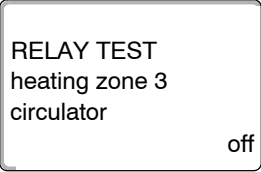

RELAY TEST
heating zone 3
circulator

off

The display shows the set value.

Release "Display" to save your settings.



Press "Back" to return to the next level up.

DHW



Press "Display" to call up a submenu (here: "heating zone 0").

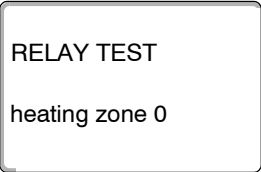

RELAY TEST
heating zone 0

The display shows the selected submenu.



Turn the dial until main menu "DHW" appears.

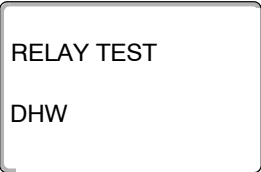

RELAY TEST
DHW

The display shows the selected submenu.



Press "Display" to call up another submenu (here: "DHW loading").

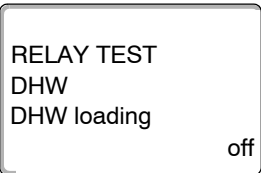

RELAY TEST
DHW
DHW loading

off

The display shows the selected submenu.



+



Hold down "Display" and turn the dial until the desired value appears (here: "on").

DHW data
DHW
DHW loading

on

The display shows the set value.

Release "Display" to save your settings.



Press "Back" to return to the next level up.

KSE



Press "Display" to call up a submenu (here: "heating zone 0").

RELAY TEST
heating zone 0

The display shows the selected submenu.



Turn the dial until submenu "KSE" appears.

RELAY TEST
KSE

The display shows the selected submenu.



Press "Display" to call up another submenu (here: "fault relay").

RELAY TEST
KSE
fault relay

no fault

The display shows the selected submenu.

8 Relay test

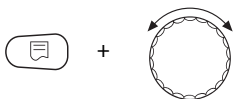

Hold down "Display" and turn the dial until the desired value appears (here: "fault").

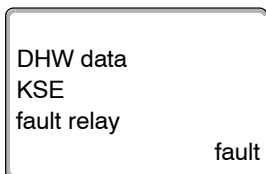

The display shows the set value.

Release "Display" to save your settings.



Press "Back" to return to the next level up.



USER NOTE

At the end of the "relay test", all adjustments are cancelled.

9 Fault messages

Fault	Effect on control characteristics	Possible causes of fault	Remedy
Boiler x	<ul style="list-style-type: none"> – Boiler protection (freeze protection) is not guaranteed. – No DHW. – No heating. 	<ul style="list-style-type: none"> – UBA reports lockout fault. 	<ul style="list-style-type: none"> – Press burner reset button. – Check UBA cabling. – Check the boiler; see technical boiler documentation.
Boiler x Status: Display code/ Service code	<ul style="list-style-type: none"> – Boiler protection (freeze protection) is not guaranteed. – No DHW. – No heating. 	<ul style="list-style-type: none"> – The EMS boiler reports a lockout fault with display code and service code. 	<ul style="list-style-type: none"> – Check the boiler documentation for a detailed description of this fault and take the measures specified there. – Press "Reset" on the BC10.
Boiler x EMS fault	<ul style="list-style-type: none"> – Boiler protection (frost protection) cannot be assured. – No DHW. – No heating. 	<ul style="list-style-type: none"> – The EMS boiler reports a lockout fault. 	<ul style="list-style-type: none"> – Check the display and service code on the BC10. – Check the detailed description of the fault in Tab. 14, page 75 and take the measures specified there. – Press "Reset" on the BC10.
DHW EMS fault	<ul style="list-style-type: none"> – No DHW. 	<ul style="list-style-type: none"> – The EMS boiler reports a fault with the DHW function. 	<ul style="list-style-type: none"> – Check the display and service code on the BC10. – Check the detailed description of the fault in Tab. 13, page 74 and take the measures specified there.
Boiler x Maintenance Hxx	<ul style="list-style-type: none"> – None. – Service message, no system error. 	<ul style="list-style-type: none"> – Example: maintenance interval has expired. 	<ul style="list-style-type: none"> – Maintenance required, see boiler documentation or service call table.
Boiler x manual mode	<ul style="list-style-type: none"> – No automatic function, such as heating program. 	<ul style="list-style-type: none"> – This is not a fault. 	<ul style="list-style-type: none"> – Turn the dials on the BC10 base controller to "Aut" if manual mode is no longer required.
Connection BRx	<ul style="list-style-type: none"> – Frost protection cannot be assured. Heating of DHW is stopped. – There is no heating. 	<ul style="list-style-type: none"> – UBA incorrectly connected. – UBA switched off. UBA defective. – Module defective. 	<ul style="list-style-type: none"> – Check connection. – Switch on UBA. – Replace UBA. – Replace the KSE module.

Tab. 10 Fault messages

10 Actual data

Using the "act system data" menu you can display the set and actual values. The menus described in these instructions relate exclusively to the Logamatic 4323 control panel and the most commonly used FM441 and FM442 modules as well as the FM456 and FM457 function modules.

Some display values are separated by a slash. The number in front of the slash specifies the set value of each corresponding parameter and the figure after the slash is the actual value.

You can display data for the following components (if installed):

- Low loss header
- Boiler
- Heating zones
- DHW
- Monitor data of other installed modules

10.1 Low loss header monitor data

With the monitor menu "low loss header," you can scan the data relating to the low loss header.



Call up the service level. "general data" appears as the first main menu.



Turn the dial until main menu "act system data" appears.

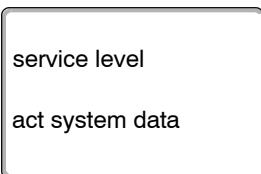

The display shows the selected main menu.



Press "Display" to call up a submenu (here: "low loss header").

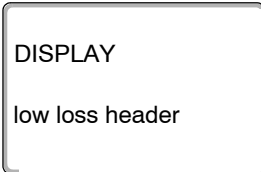

The display shows the selected submenu.



Press "Display".

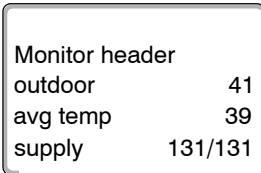

The "avg temp" value describes the outdoor temperature, taking into consideration the specified type of building with which the heating curve was calculated.



Press "Back" to return to the next level up.

10.2 Boiler monitor data

Using the monitor menu "boiler" you can display the boiler data.



Call up the service level. "general data" appears as the first main menu.



Turn the dial until main menu "act system data" appears.

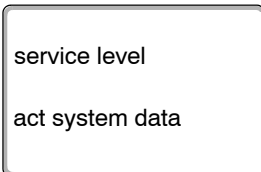

The display shows the selected main menu.



Press "Display".



The display first shows submenu "low loss header".



Turn the dial until the desired submenu appears (here: "boiler 2").

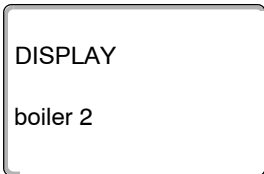

The display shows the selected submenu.



Press "Display".

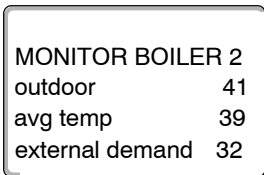

The display shows the selected submenu.

The "avg temp" value describes the outdoor temperature, taking the specified type of building into consideration, with which the heating curve is calculated.



Turn the dial to scroll through additional boiler monitor data.

The boiler monitor data is displayed depending on the boiler type.

For a description, see the following tables.



Press "Back" to return to the next level up.



USER NOTE

The service call "after run time" is only applicable with "No of boilers 1".

The service call "after date" is only displayed if "No of boilers 1" is displayed – but it applies to all boilers.

Boiler monitor data for boilers with EMS/UBA 3

Operation → page 69.

Display	Function	Unit	Value range
Outdoor	Actual outdoor temperature	°F (°C)	
Avg temp	Average outdoor temperature taking into account the building type setting for calculating the heating curve	°F (°C)	
Ext. demand	Set point for the supply temperature, only in connection with function modules FM456 and FM457	°F (°C)	
Supply	Supply temperature set value/actual value	°F (°C)	
Return	Actual return temperature	°F (°C)	
Starts	Number of burner starts		
Status	Current operating status		
Service code	Service code to differentiate between status messages		
KIM	Boiler type and KIM version (KIM = boiler identification module)		
UBA 3	Software version of the universal automatic burner controller		
Output	Current boiler output	%	0 – 100
Max. output	Maximum enabled boiler output	%	0 – 100 or EMS-DHW
Circulator	Current output of the boiler pump with modulating pumps and switching state for one-stage pumps	%	0 – 100 or on/off
Maximum	Maximum boiler output	kBTU/hr (kW)	
Max. output	Upper limit for the modulation	%	0 – 100
Min. output	Lower limit for the modulation	%	0 – 100
Flue gas	Actual flue gas temperature	°F (°C)	
Air temp.	Measured temperature of the combustion air	°F (°C)	
Pressure	Measured heating system operating pressure	psi (bar)	
Ionization curnt	Actual flame current	μA	
Ignition	Ignition		on/off
Flame	Flame		on/off
Valve 1	Burner valve stage 1		open/closed
Valve 2	Burner valve stage 2		open/closed

Tab. 11 Boiler monitor data for boilers with EMS/UBA 3

Operation → page 69.

Display	Function	Unit	Value range
Outdoor	Actual outdoor temperature	°F (°C)	
Avg temp	Average outdoor temperature taking into account the building type setting for calculating the heating curve	°F (°C)	
Ext. demand	Set point for the supply temperature, only in connection with function modules FM456 and FM457	°F (°C)	
Supply	Supply temperature set value/actual value	°F (°C)	
Return	Actual return temperature	°F (°C)	
Starts	Number of burner starts		
Status	Current operating status		
Service code	Service code to differentiate between status messages		
BIM	Boiler type and BIM version (BIM = boiler identification module)		
MC10	Software version of the Logamatic MC10 control panel		
SAFe	Type and software version of the SAFe burner controller		
Output	Current boiler output	%	0 – 100
Max. output	Maximum enabled boiler output	%	0 – 100 or EMS-DHW
Circulator	Current output of the boiler pump with modulating pumps and switching state for one-stage pumps	%	0 – 100 or on/off
Maximum	Maximum boiler output	kBTU/hr (kW)	
Max. output	Upper limit for the modulation	%	0 – 100
Min. output	Lower limit for the modulation	%	0 – 100
Flue gas	Actual flue gas temperature	°F (°C)	
Air temp.	Measured temperature of the combustion air	°F (°C)	
Pressure	Measured heating system operating pressure	psi (bar)	
Ionization currnt	Actual flame current	μA	
Ignition	Ignition		on/off
Flame	Flame		on/off
Valve 1	Burner valve stage 1		open/closed
Valve 2	Burner valve stage 2		open/closed

Tab. 12 Boiler monitor data for boilers with EMS/SAFe

10.3 Additional fault messages with EMS

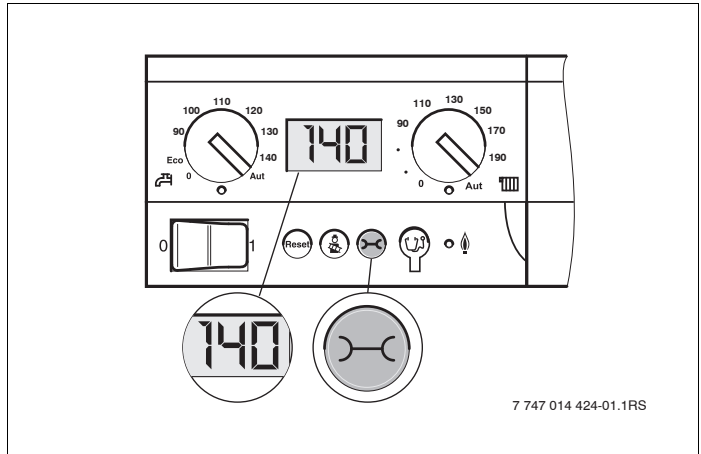



Fig. 12 Call up display and service code
(e.g. Logamatic MC10 control panel/BC10 base controller)

Calling up status (display code) and service codes

If a fault occurs, the status is immediately displayed by the control panel. The display flashes when a locking safety shutdown occurs.

- Press "Status display"  to check the service code.
- Press "Status display" several times to display additional service information until the boiler status is displayed again.

DHW EMS faults

DC: Display code (status)

SC: Service code

DC	SC	Fault	Effect on control characteristics	Possible causes of fault	Remedy
A01	808	DHW sensor defective	<ul style="list-style-type: none"> – DHW is no longer heated. 	<ul style="list-style-type: none"> – Sensor connected incorrectly or defective. – Breakage or short circuit in the sensor lead. – Sensor aged. 	<ul style="list-style-type: none"> ● Check connection of the DHW sensor and replace if necessary.
A01	810	DHW remains cold	<ul style="list-style-type: none"> – There is a constant attempt to heat the DHW storage tank. – Solar heating system does not start. 	<ul style="list-style-type: none"> – Constant drawing or system leak. – Sensor connected incorrectly or defective. – Breakage or short circuit in the sensor lead. – Sensor aged. – Loading pump incorrectly connected or defective. 	<ul style="list-style-type: none"> ● Fix any leaks. ● Check connection of the DHW sensor and replace if necessary. ● Check function of sensor and primary pump. ● Check sensor connection on DHW storage tank.
A01	811	Thermal disinfection	<ul style="list-style-type: none"> – Thermal disinfection has been interrupted. 	<ul style="list-style-type: none"> – Constant drawing or system leak. – Sensor connected incorrectly or defective. – Breakage or short circuit in the sensor lead. – Sensor aged. – Loading pump incorrectly connected or defective. 	<ul style="list-style-type: none"> ● Fix any leaks. ● Check connection of the DHW sensor and replace if necessary. ● Check function of sensor and primary pump. ● Check sensor connection on DHW storage tank.

Tab. 13 Possible messages with DHW EMS faults

EMS faults

DC	SC	Fault	Effect on control characteristics	Possible causes of fault	Remedy
AD 1	817	Air temperature sensor defective	– Fan speed cannot be matched optimally.	– This fault message is generated if a temperature is recorded at the air temperature sensor which is too low (< -22 °F (-30 °C)) or too high (> 212 F °(100 °C)).	<ul style="list-style-type: none"> ● Check air temperature sensor incl. plug-in connection at the SAFE, and replace if required.
AD 1	818	Boiler remains cold	– Inadequate heating system supply.	– This fault message is generated if the boiler remains below the pump logic temperature (117 °F (47 °C)) for a specified period even though the burner is operating.	<ul style="list-style-type: none"> ● Check system design and pump parameters; correct if required. ● Check the non-return valve function and replace if necessary. ● Check whether gravity brakes are in working position.
AD 1	819	Constant oil pre-heater signal	– Burner attempts to start.	– The oil preheater receives an enable signal, even though it is switched off.	<ul style="list-style-type: none"> ● Check the plug assignment on the SAFE and oil preheater, and correct if required.
AD 1	820	Oil too cold	– Burner attempts to start.	– The oil pre-heater does not respond within 6 minutes, indicating that the oil has reached operating temperature.	<ul style="list-style-type: none"> ● Check the electrical connection of the oil preheater; if OK, replace the oil preheater.

Tab. 14 Possible messages with EMS faults

**USER NOTE**

Other faults are described in the technical documentation for the boiler.

10.4 Service messages for boilers with EMS

DC: Display code (status)

DC	Service	Possible cause	Remedy	EMS with boiler
H 1	Flue gas temperature too high	As soon as the flue gas temperature has exceeded a certain limit (230 °F (110 °C)), the burner is switched to stage 1, and this service message is generated. The message will only be cleared when the command "Reset maintenance message" is issued.	<ul style="list-style-type: none"> ● Cleaning the boiler. ● Check the position, equipment level, and state of the plate insert, and correct if necessary. 	SAFe
H 2	The burner fan runs too slowly	The SAFe must create an unusually high PWM signal for the required speed.	<ul style="list-style-type: none"> ● Check the burner fan for contamination, and clean or replace if necessary. 	SAFe
H 3	Hours of operation expired	Does not occur in conjunction with Logamatic 4323.		SAFe
H 4	Low flame sensor current	<p>The flame signal is only just above the SAFe shutdown threshold.</p> <ul style="list-style-type: none"> – Flame sensor or holding bracket is dirty. – Mixing system incorrectly aligned in relation to sight tube. – Defective flame sensor/SAFe electrical connection. – Flame sensor or SAFe defective. 	<ul style="list-style-type: none"> ● Check flame sensor and holding bracket (mirror) for dirt, and clean if necessary. ● Check the orientation of the mixing system towards the sight tube and correct if necessary. ● Check the mixing system for contamination and clean if necessary. ● Check the flame sensor plug-in connection on the SAFe. ● Check burner setting and correct if necessary. ● Check the flame sensor signal for stages 1 and 2 using the RC35. Replace the flame sensor if this is not OK. 	SAFe

Tab. 15 Service messages

DC	Service	Possible cause	Remedy	EMS with boiler
H 5	High ignition delay	<p>At the last burner start, the flame was established after a long delay:</p> <ul style="list-style-type: none"> – Defective oil supply. – Defective ignition system. – Defective burner adjustment. – Defective burner components. 	<ul style="list-style-type: none"> ● Check oil supply. ● Check ignition via a relay test (RC35) or function test (RC35); check ignition electrode for contamination or damage (electrode gap) and replace if required. ● Replace the oil nozzle. ● Replace the oil cut-off valve of the oil pre-heater. ● Check the mixing system and clean if necessary. ● Check burner setting, correct if necessary. 	SAFe

Tab. 15 Service messages

DC	Service	Possible cause	Remedy	EMS with boiler
H 6	Frequent flame blow-out	During the last burner starts, the flame blew off frequently. <ul style="list-style-type: none"> – Defective oil supply. – Defective ignition system. – Defective burner adjustment. – Defective burner components. 	<ul style="list-style-type: none"> ● Call up the fault memory of blocking faults to check in which operating phase the flame blew off. If only 6U/511 (no flame established) is present: <ul style="list-style-type: none"> ● Check oil supply. ● Check the flame sensor current via relay test (RC35) or function test (RC35). ● Check the ignition via relay test (RC35) or function test (RC35). ● Replace the oil nozzle. ● Replace the oil cut-off valve of the oil pre-heater. ● Check the mixing system and clean if necessary. ● Check burner setting, correct if necessary. If other blocking faults (flame blow-off after the flame was established successfully) are present: <ul style="list-style-type: none"> ● Check burner setting and correct if necessary. ● Check oil supply equipment. ● Plug assignment 1/2. Check magnetic valve (fault 6L/516). ● Check flame sensor current during operation. If signal < 50 μA, check holding bracket and clean or replace flame sensor if necessary. 	SAFE

Tab. 15 Service messages

DC	Service	Possible cause	Remedy	EMS with boiler
H 7	System pressure	The operating pressure in the heating system has dropped too low.	<ul style="list-style-type: none"> ● Top up the heating water until the operating pressure > 14.5 psi (1.0 bar). 	UBA 3
H 8	According to date	Does not occur in conjunction with this control panel.		SAFe
H 9	Incorrect pump	The wrong pump type is recognized via the pump interface.	<ul style="list-style-type: none"> ● Install correct pump. 	UBA 3
H10	High flame current	Over a longer period, high flame currents have been measured during operation.	<ul style="list-style-type: none"> ● Service the heating system. ● Check connecting lead between SAFe and flame sensor, and remedy fault. ● Replace flame sensor. ● Replace SAFe. 	SAFe
H11	SLS sensor fault	Cold water inlet sensor lead break.	<ul style="list-style-type: none"> ● Check sensor and replace if required. 	UBA 3.5
H12	SLS sensor fault	Storage tank sensor lead break.	<ul style="list-style-type: none"> ● Check sensor and replace if required. 	UBA 3.5

Tab. 15 Service messages

11 Sensor characteristics

Using the diagram you can check whether temperature and resistance correlate.

- Isolate the heating system from the power supply before taking any readings.

Fault test (without room temperature sensor)

- Remove the sensor terminals.
- Check the resistance at the sensor lead ends using an ohmmeter.
- Check the sensor temperature with a thermometer.



USER NOTE

For all curves, the sensor tolerance is up to 3 %/77 °F (25 °C).

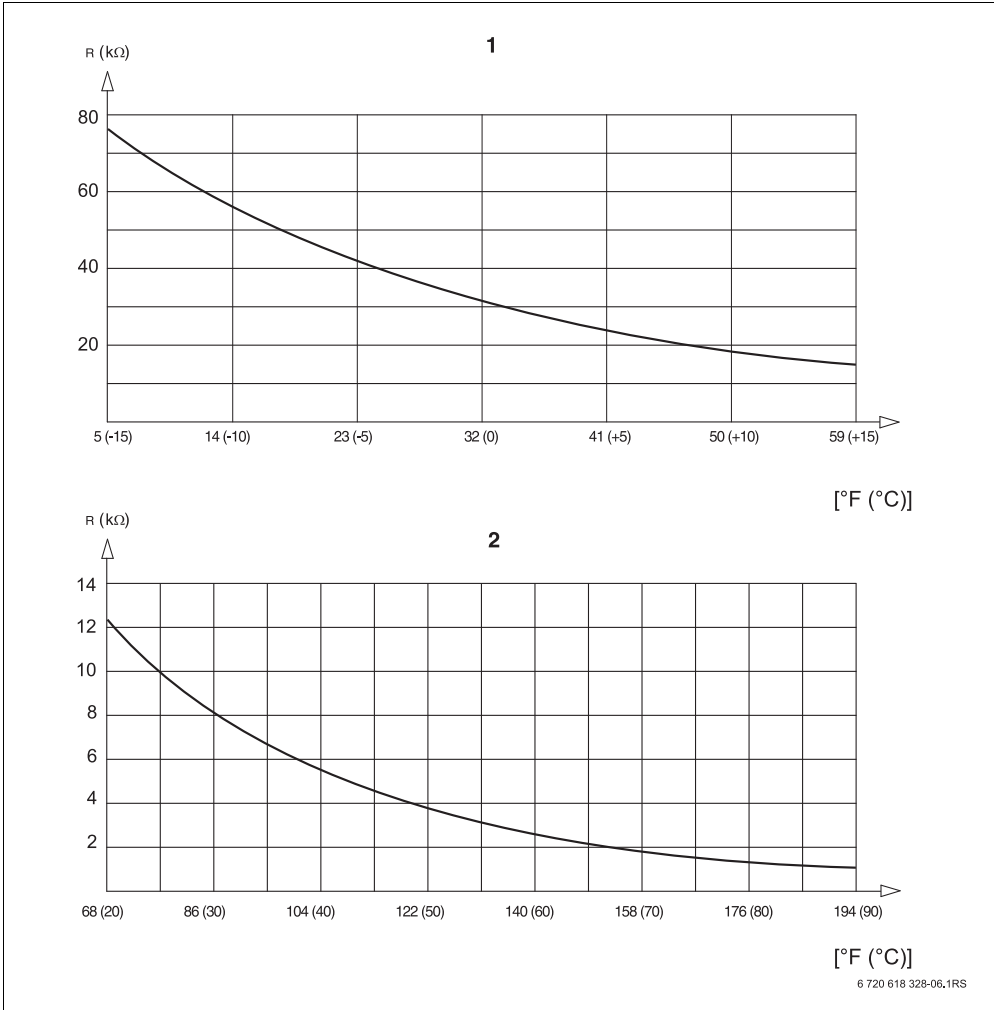

Fig. 13 Outdoor temperature sensor and boiler water, supply, system supply, system return, DHW temperature sensors

- 1 Outdoor temperature sensor curve
- 2 Curve – boiler water, supply, system supply, system return, DHW temperature sensors

12 Index

0 – 10 V input	10, 11, 25, 28	O	Optimization – DHW	47
A		R		
Act system data	68	Recirculation	58	
B		Relay	62	
BC10 basic controller	20	Relay test	62	
Boiler type	36	S		
Boiler type table	22	Sensor connections	17	
C		Slot assignment	16	
Cascade module	8	Software version	15	
Collective fault output	10	T		
D		Thermal disinfection	51	
DHW heating	43	Thermal disinfection temperature	53	
Disposal	7			
E				
EMS/SAFe	19			
EMS/UBA 3	19			
Energy Management System	19			
External heat	35			
F				
Fault	67			
FM456	8			
FM457	8			
H				
Heating zone function	13			
I				
Identification of the boiler types	19			
Inputs and outputs (terminal designation)	17			
J				
Jumper switches	12			
K				
KSE Modules	8			
L				
Leftover heat	48			
Low loss header	68			

United States and Canada

Bosch Thermotechnology Corp.
50 Wentworth Avenue
Londonderry, NH 03053
Tel. 603-552-1100
Fax 603-584-1681
www.buderus.net
U.S.A.

Products manufactured by
Bosch Thermotechnik GmbH
Sophienstrasse 30-32
D-35576 Wetzlar
www.buderus.de

Bosch Thermotechnology Corp. reserves the right
to make changes without notice due to continuing
engineering and technological advances.

Buderus