

Switching states

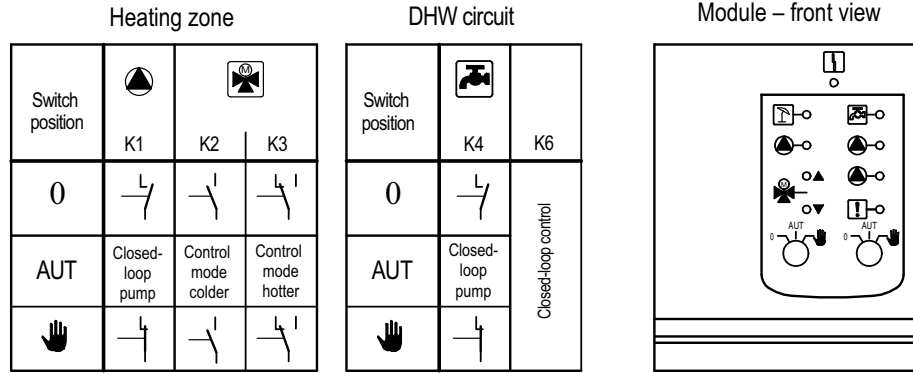

Internal BUS in control panel

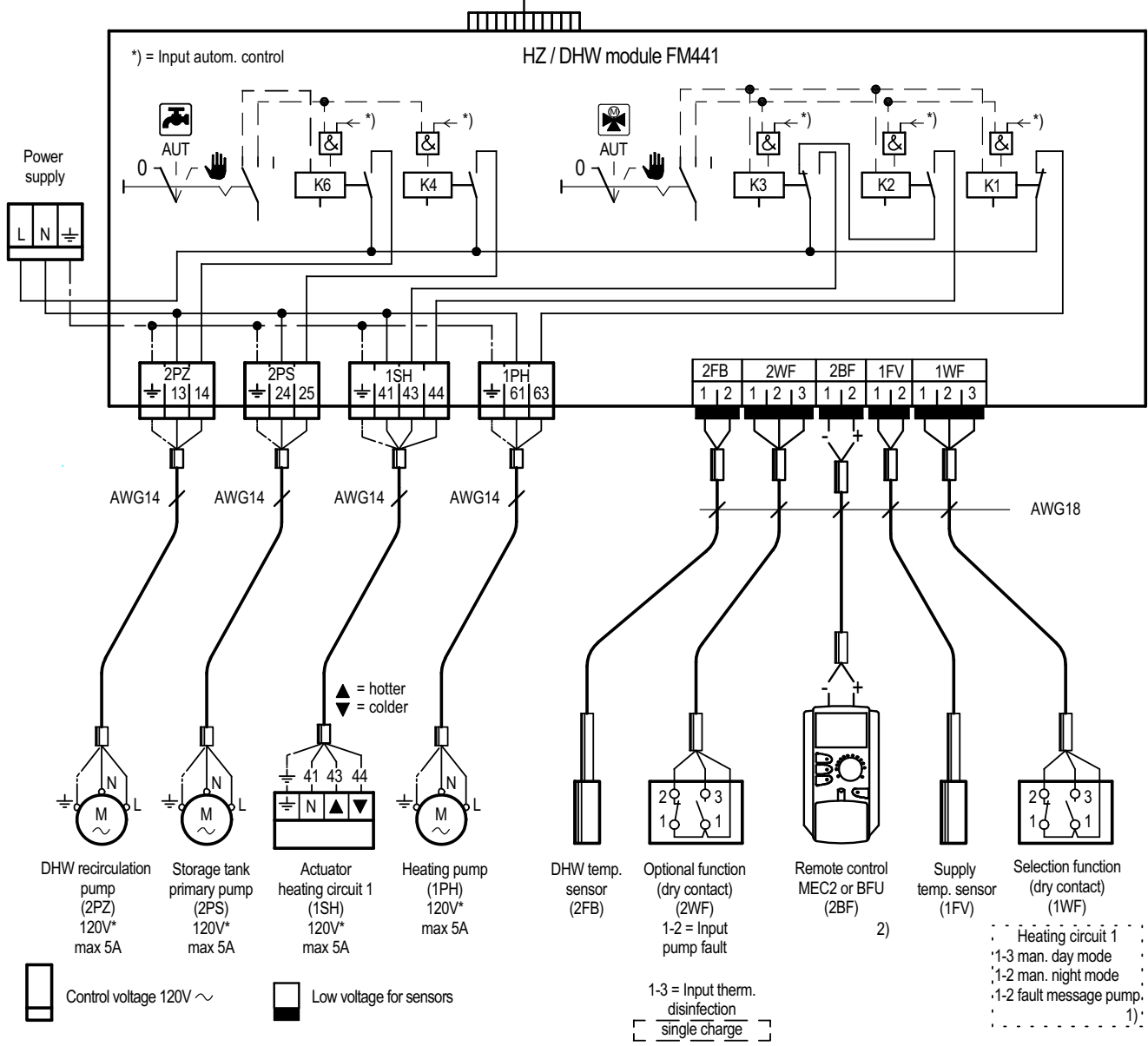

1) Function only possible if no BFU is connected or no MEC2 is assigned.
 2) **Please note!** Only one MEC2 can be allocated to each control. The MEC2 can be plugged into the control module or, using the wall installation kit (optional), wired to the ZM or FM module.
 *) Total current for the modul can not exceed 10A.

Installation examples (see back)

Legend:

- HZ heating circuit
- THV thermostatic radiator valve
- DHW DHW heating

