

Installation Manual

SU 160-200



Save These Instructions !

TABLE OF CONTENTS

1	General Guidelines	3
2	Technical Data and Tank Connections	4
3	Transportation and Placement	5
4	Installation	6
5	Putting Into Operation	8
6	Maintenance Procedures	9
7	Testing of Magnesium Anode Rod	11

The SU Series indirect-fired water heaters are delivered assembled.

Only the screw-on feet, factory furnished piping accessories (included in packaging) and desired tank temperature control (not furnished) must be installed in the field.

This manual contains information regarding installation and maintenance of the SU Series indirect-fired water heaters, installation of its piping accessories and placement of aquastats or sensors for temperature control.

NOTE: This manual is for reference only. The manual does NOT purport to address all design, installation and safety considerations. It is the responsibility of the user of this manual to determine the applicability and safety of each individual application and ensure its compliance with local building codes.

It is expected that the user/installer is a licensed heating contractor with knowledge of accepted industry practices for the installation and maintenance of the equipment and various applications of the equipment involved.

2 Technical Data and Tank Connections

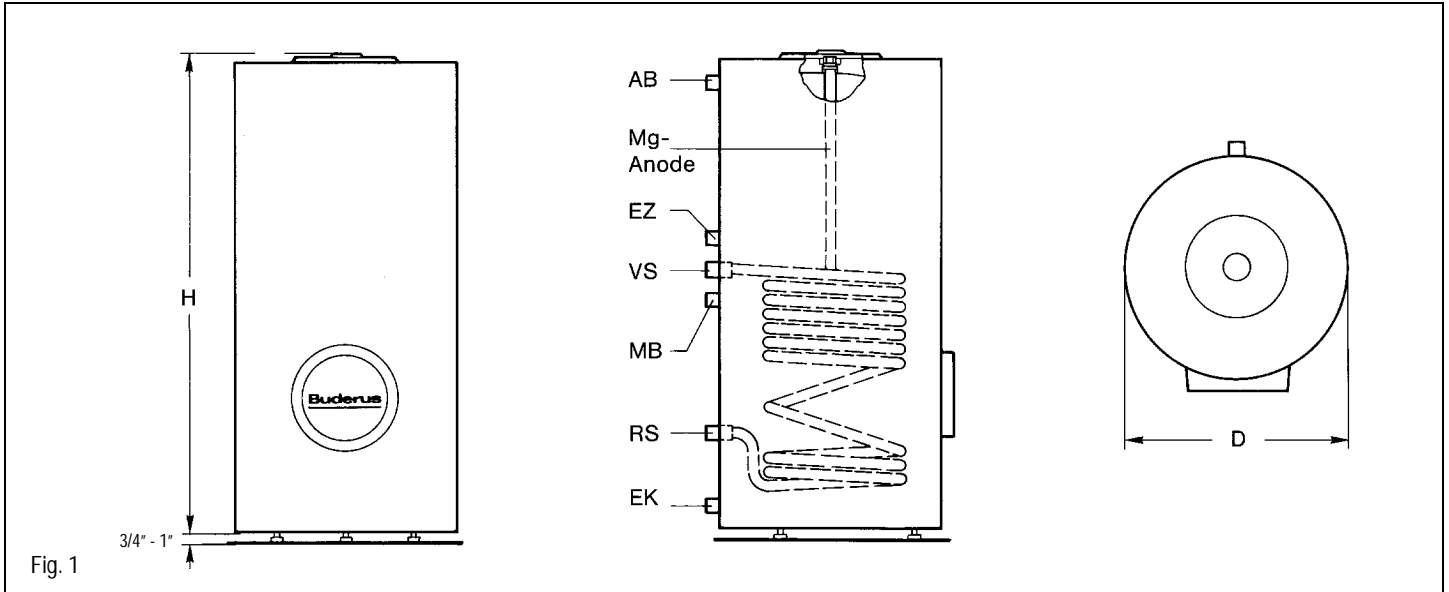

Tank Model	D (In.)	Height (In.)	Weight (Lbs.)	Volume (Gal.)	AB	EZ	VS/RS	EK
SU160	21 ^{3/4}	46 ^{3/4}	216	42	1"	3/4"	1"/1"	1"
SU200	21 ^{3/4}	56 ^{3/4}	242	53	1"	3/4"	1"/1"	1"

KEY

- AB = DHW Outlet/Relief Valve connection
- EZ = DHW Recirculation return/Honeywell aquastat sensing point
- VS = Boiler water supply
- RS = Boiler water return
- EK = Cold water feed/drain connection
- MB = Immersion well for Ecomatic DHW sensor/SP34D sensor

The storage tank can be moved in the original packaging or unpacked and moved with a Buderus hand cart* (Fig. 2).

* must be ordered separately.

- Remove plastic film.
- Remove screw-on feet and other accessories from packaging.
- Remove tank top cover. Tilt tank and lay on its side on the packaging lid.
- Screw the three feet into the tank bottom. They should extend about 3/4".
- Place the water heater on a level and sufficiently strong surface.
- Adjust the screw-in feet to level the tank (Fig. 3).
- The indirect tank must be placed indoors in a location kept at a minimum temperature of 32°F.
- Drain the tank if it is not used for an extended time period and a freezing condition could occur.
- Refer to recommended clearances for adequate access for piping, pumps and service (Fig. 4).

NOTE: *Maintain 2" clearance between hot water piping and combustible surfaces.*

NOTE: *The tank can be installed on combustible surfaces provided the screw-in feet are used. Do not install on carpeting.*

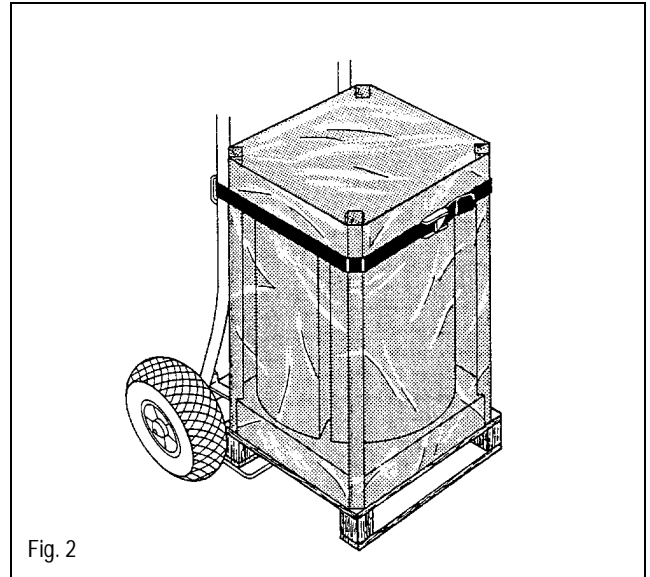

Fig. 2

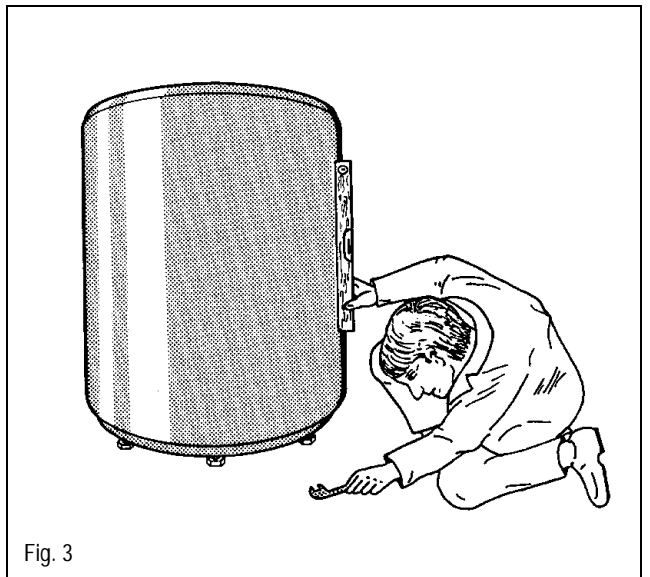

Fig. 3

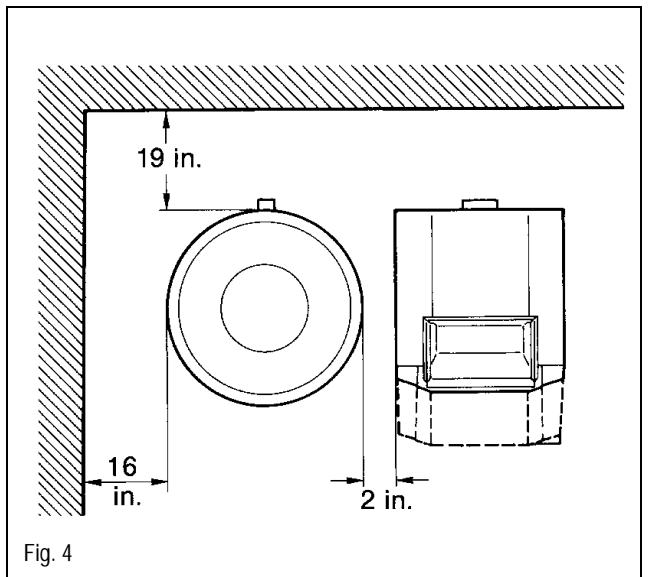

Fig. 4

4 Installation

The installation of the indirect-fired domestic hot water tank and all associated piping must be in accordance with all applicable codes and regulations. All work must be performed by a licensed contractor.

- Install an approved and properly sized pressure and temperature relief valve (Fig. 5).
- Pipe the P & T relief valve discharge pipe directly to a drain without any shutoff valves or restrictions. Maintain same size piping as on the P & T discharge.

NOTE: *It is advised to periodically check the operation of the P & T valve.*

- Installation of a properly sized thermal expansion tank on the domestic hot water line is required when a backflow preventer is installed on the cold water feed.

Tank safety limits:

Heating water temperature: max 160°C (320°F)
 Heating water oper. pressure: max 25 bar (362 psi)
 DHW temperature: max 95°C (203°F)
 DHW oper. pressure: max 10 bar (145 psi)*
 * 100 psi max in Massachusetts

Installation of furnished accessories

NOTE: *All tank tappings are metric, the supplied accessories permit conversion to NPT piping. Follow instructions supplied with the tank fittings for sealing of all tank connections.*

Cold feed/drain: Use 1" x 3/4" x 3/4" tee for SU 160 and SU 200 models. Install 3/4" piping for cold feed and 3/4" drain (not furnished).

Boiler supply/return: Use 1" x 1" couplings.

Recirculation tapping: Use 3/4" x 3/4" coupling.

This tapping can be used for several purposes.

Option 1: DHW recirculation. Pipe DHW recirc line to this tapping. If not used, install 3/4" brass plug (not furnished).

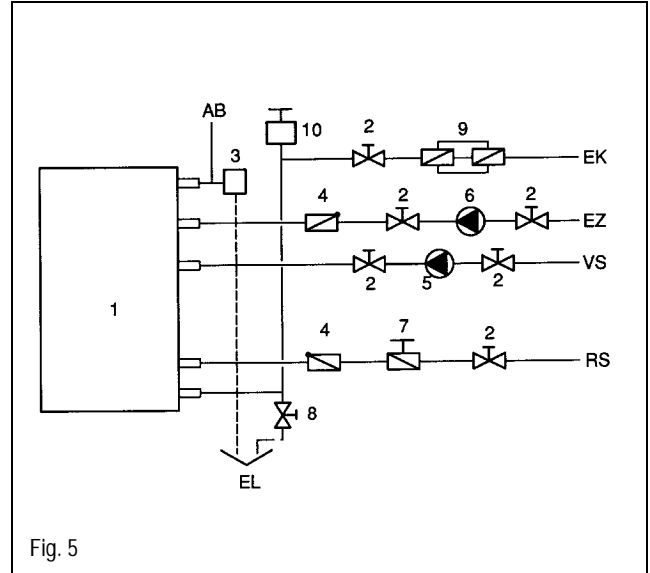

Fig. 5

1	Indirect-fired hot water tank
2	Service valve
3	P & T relief valve
4	Flow check
5	Tank charging pump
6	Optional recirc pump
7	Air purge valve
8	Drain valve
9	Backflow preventer
10	Vacuum relief

Option 2: A Honeywell L4006 aquastat (not furnished) or equivalent can be used by installing the furnished well into the 3/4" coupling. A recirculation line is now to be piped into the cold feed/drain connection external to the tank.

DHW outlet: Use 1" x 3/4" x 3/4" tee for SU 160 and SU 200 models.

Install the P & T valve in the 3/4" tapping.

Installation of temperature sensor/aquastat

NOTE: *The SU Series tanks are NOT supplied with an aquastat or temperature control. Guidelines below indicate proper installation procedures for different temperature controls. Buderus Hydronic Systems, Inc. can provide the Ecomatic DHW control and SP34D components.*

Case 1: Buderus Ecomatic DHW control

- Fully insert the Ecomatic DHW sensor together with spacers and compensating spring into the immersion well (MB) (Fig. 6).
- Slide the fastening clip on the head of the immersion well (Fig. 7).

Case 2: Goldline SP34D priority DHW control

- Fully insert the SP34D probe together with the furnished spacers and compensating spring into the immersion well (MB) (Fig. 6).
- Mount the Goldline SP34D remotely. The probe leads can be extended with 18 gauge wire.

Case 3: Honeywell L4006A aquastat (or equivalent) control

- Install the furnished Honeywell immersion well into the 3/4" coupling installed on the recirculation tapping (EZ).
- Mount the L4006A or equivalent to this immersion well.

Magnesium anode rod

- Verify that a magnesium rod is installed (Fig. 8).

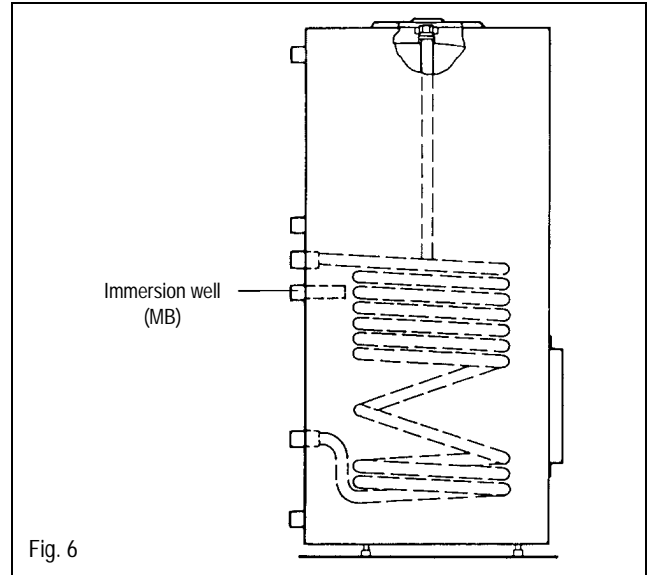

Fig. 6

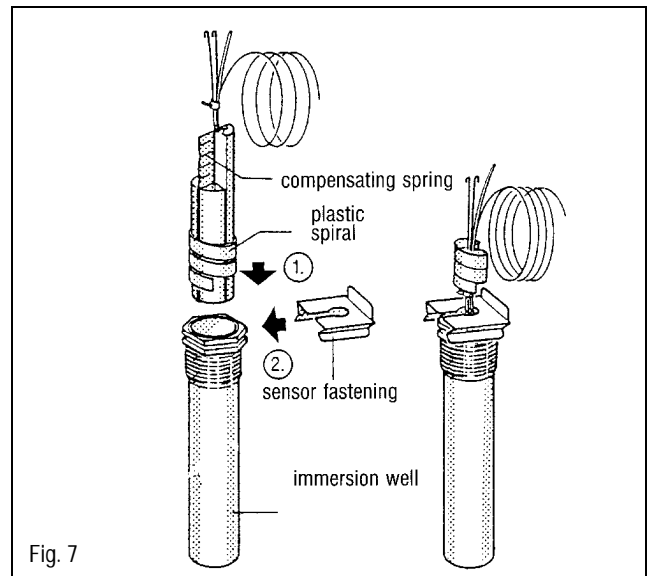

Fig. 7

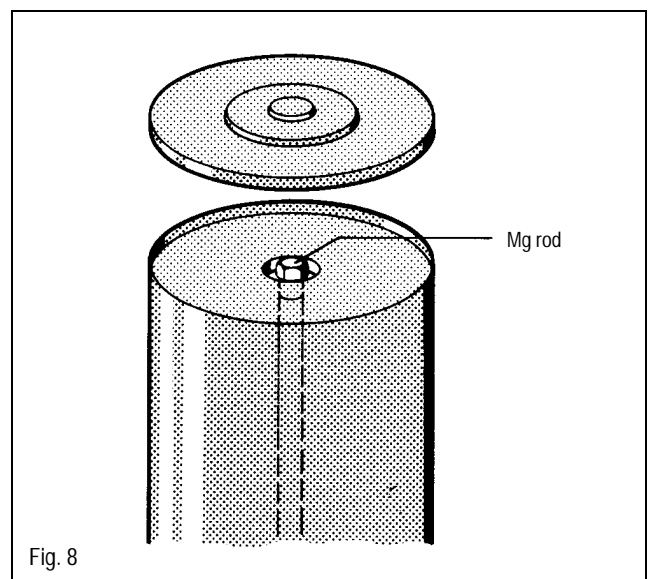

Fig. 8

5 Putting Into Operation

- Prior to initial start-up, verify that the indirect-fired water heater is filled with water and that cold water can flow into the tank.
- Check all pipes and connections for leaks.
- Verify that the magnesium rod or optionally available electric inert rod* is connected and functions properly.
 - * must be ordered separately from Buderus Hydronic Systems, Inc., suitable for high sulphur water conditions.
- Verify proper operation of tank operating controls (furnished separately).

NOTE: *The installation must initially be put into operation by the installing contractor in the presence of the owner of the installation.*

Recommendations

NOTE: *The indirect-fired water heater may only be filled with drinking water, unless there is a written agreement to the contrary.*

It is recommended that a licensed contractor or maintenance company checks and cleans the indirect-fired water heater at least once every 2 years.

For unfavorable water conditions (hard or very hard), extreme high usage and/or high temperature load, more frequent inspections and cleanings may be necessary.

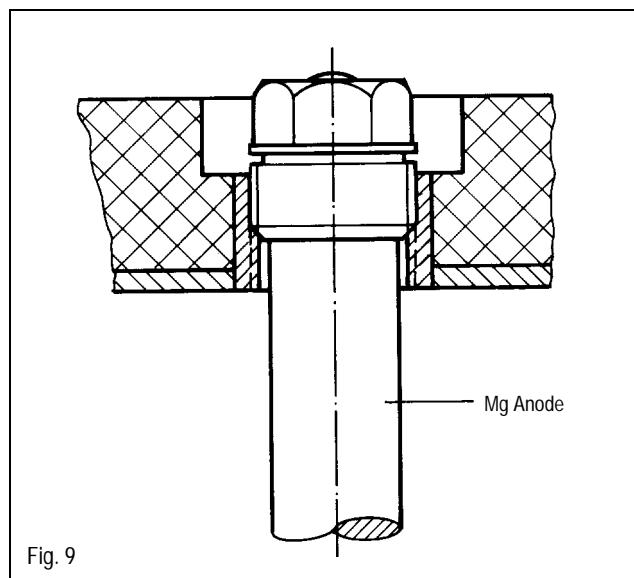

Cleaning procedure

- Shut off the power to the heating installation before cleaning.
- Shut off the cold water feed, open the tank drain. To vent air, open a faucet at a higher location.
- Drain the tank and remove the tank top cover.
- Remove and inspect the magnesium rod. If the diameter of the rod is 1/2"-3/4" or less, it is advisable to install a new rod (Fig. 9).
- Reinstall the magnesium rod and tank top cover.

6 Maintenance Procedures

Cleaning procedure *cont'd*

- Remove front clean-out cover (Fig. 10).
- Remove the hexhead bolts and remove the clean-out port.
- Inspect tank interior and clean if necessary.

NOTE: *Never break up the calcified deposits with a sharp object as it may damage the thermoglaze tank coating.*

If cleaning of the coil is needed, fire the boiler and operate the tank charging pump until the coil is very hot. Now, spray cold water directly on the coil with a hose through the clean-out port. Repeat until all scale deposits are removed from the coil.

- Flush debris through the drain or remove through the clean-out port.
- Reinstall the clean-out port after cleaning. Replace gasket if necessary.

NOTE: *Hand tighten hexhead bolts. Turn bolts 3/4 turn with a wrench (recommended torque: 30 ft-lb).*

- Check the inspection port and magnesium rod for leaks.
- Reinstall inspection port insulation and cover.
- Place the system into operation.

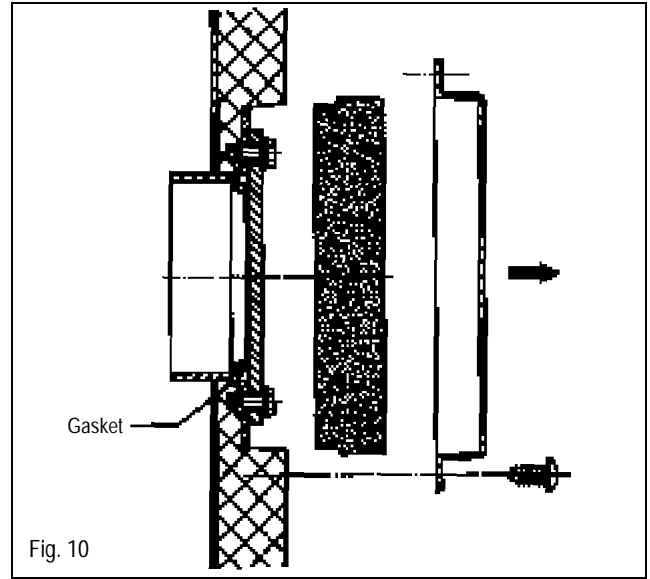

Testing and Changing-out of the Magnesium Anode Rod

1. General Information

Magnesium anode rods must be visibly inspected at least every 2 years. Buderus Hydronic Systems, Inc. recommends an additional annual inspection using an anode tester by measuring the protective current. In contrast to the visual inspection, the use of the anode tester or a high quality multi-meter does not require shutting down and draining the tank and removing the magnesium anode.

Replace the magnesium anode rod if its diameter is less than 1/2" to 3/4" (original diameter = 1 1/4"). The rod removal process differs slightly for different tank models. (Options 1-3). Sectional chain linked magnesium anodes are available for anodes listed under option 2 (See Fig. 11 and page 12). These chain linked anodes are useful in low ceiling applications.

2. Testing with anode tester or quality multi-meter

The battery operated tester must be checked first to ensure operational readiness. The red LED must light up if the tester is turned on without being connected (less than .1 mA). Replace the battery if the light is dim. Perform the test with the anode tester or high quality multi-meter. Follow the outlined procedure:

1. Remove one side of the grounding lead on the tank.
2. Set multi-meter (MM) to Dc mA (milli amps).
3. Connect black wire of MM or anode tester to grounding cable or bolt.
4. Connect red cable of MM or anode tester to the anode.
5. Ensure clean metallic surfaces for terminal connections.
6. The tank must be filled with water during the test.
7. A reading between .3 mA and 10 mA on the MM is good.
8. Record readings each year in the Table.

The protective function of the magnesium anode is guaranteed when one of the three green LED illuminates. A red LED indicates either an improperly installed anode rod which is shorted to the tank or a degraded anode rod. Visually check the rod, check the rod for proper installation and replace if necessary. Replace the magnesium anode rod if the diameter is less than 1/2" to 3/4". Properly reconnect the grounding cable after each test (Fig. 12).

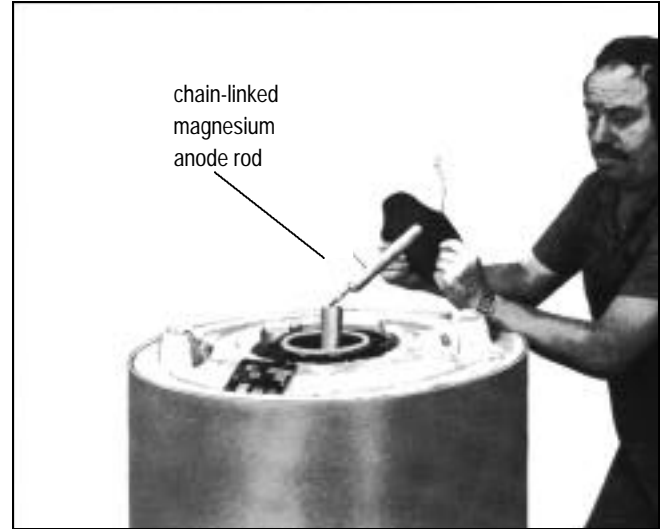

Fig. 11

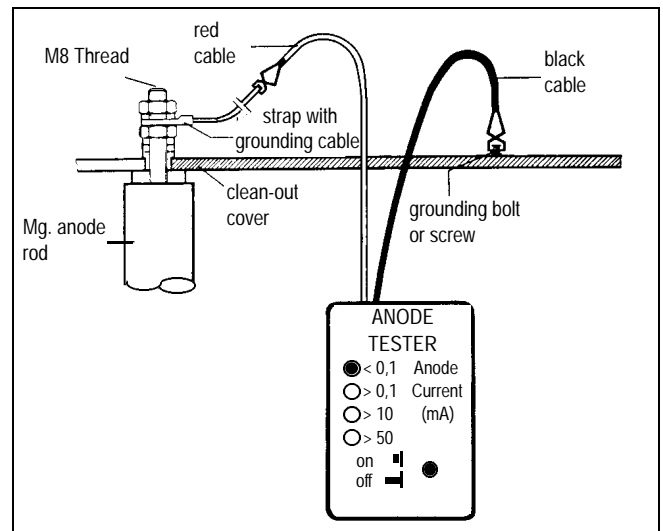

Fig. 12

Record the test date and sign off in the Table below

Date	mA Reading	Service Company/Signature

7 Magnesium Anode Rod

Anode Mounting Options

Option 1: Threaded 1 1/4" Design

Tank Models: SEN/SED 140-600 and ST/H/B/R 200-600 (Fig. 13).

Assembly Sequence:

1. Remove tank cover and insulation.
2. Loosen grounding cable from magnesium anode rod.
3. Unscrew the rod with a wrench and remove.
4. Wrap teflon tape around the threads of the replacement rod.
5. Install new rod and secure grounding cable.
6. Test for water tightness.
7. Install insulation and tank cover.

Note: The magnesium rod can also be installed into a removed clean-out cover. Check the rubber seal for degradation and replace if necessary.

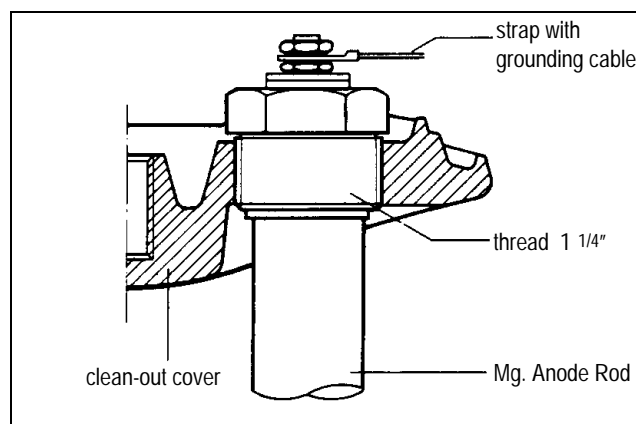

Fig. 13

Option 2: Threaded Anode Rod Design with Lock Nut

Tank Models: ST/SE/SF/TT/LT/L/S150-300/SU300 (Fig. 14).

Assembly Sequence:

1. Remove tank cover and insulation.
 2. Loosen grounding cable from magnesium anode rod.
 3. Unscrew the nuts from the clean-out cover.
 4. Remove clean-out cover and anode rod.
 5. Replace used anode with new anode according to Fig. 14.
- Note: Ensure proper placement of insulation and gasket.
6. Replace sealing gasket for clean-out cover if necessary.
 7. Install clean-out cover and anode; tighten nuts about 3/4 turn.
 8. Secure grounding cable.
 9. Test for water tightness.
 10. Install insulation and tank cover.

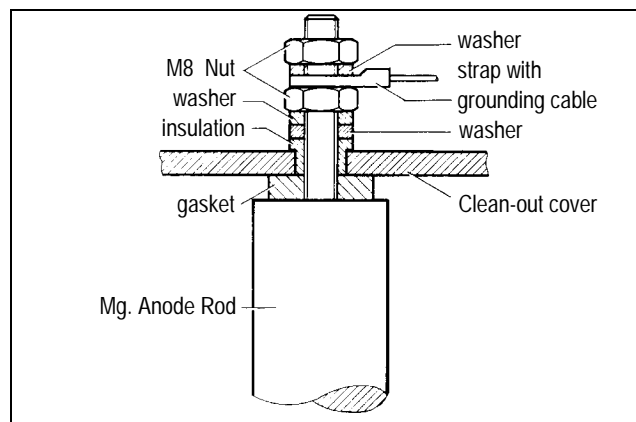

Fig. 14

Option 3: External Thread 1" or 1 1/2" Anode Rods

Tank Models: S120/SU160-200 (Fig. 15)

Assembly Sequence:

1. Remove tank cover.
2. Unscrew magnesium rod.
3. Place 4 or 5 wraps of high density teflon on the new anode.
4. Install new anode and test for water tightness.
5. Install tank cover.

Note: This magnesium anode rod cannot be tested with the anode tester!

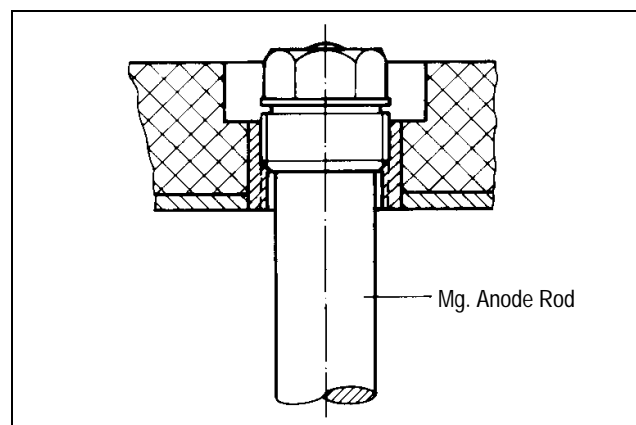

Fig. 15

Boiler installed by:
(contractor's address)

Boiler installed on:
(date of installation)

Buderus
HYDRONIC SYSTEMS

Buderus Hydronic Systems
50 Wentworth Avenue
Londonderry, NH 03053 USA
Tel: (603) 552-1100 • Fax: (603) 421-2719
www.buderus.net

Buderus Hydronic Systems, Inc. reserves the right to make changes without notice due to continuing engineering and technological advances.