

Service Manual

Ecomatic HS 2105

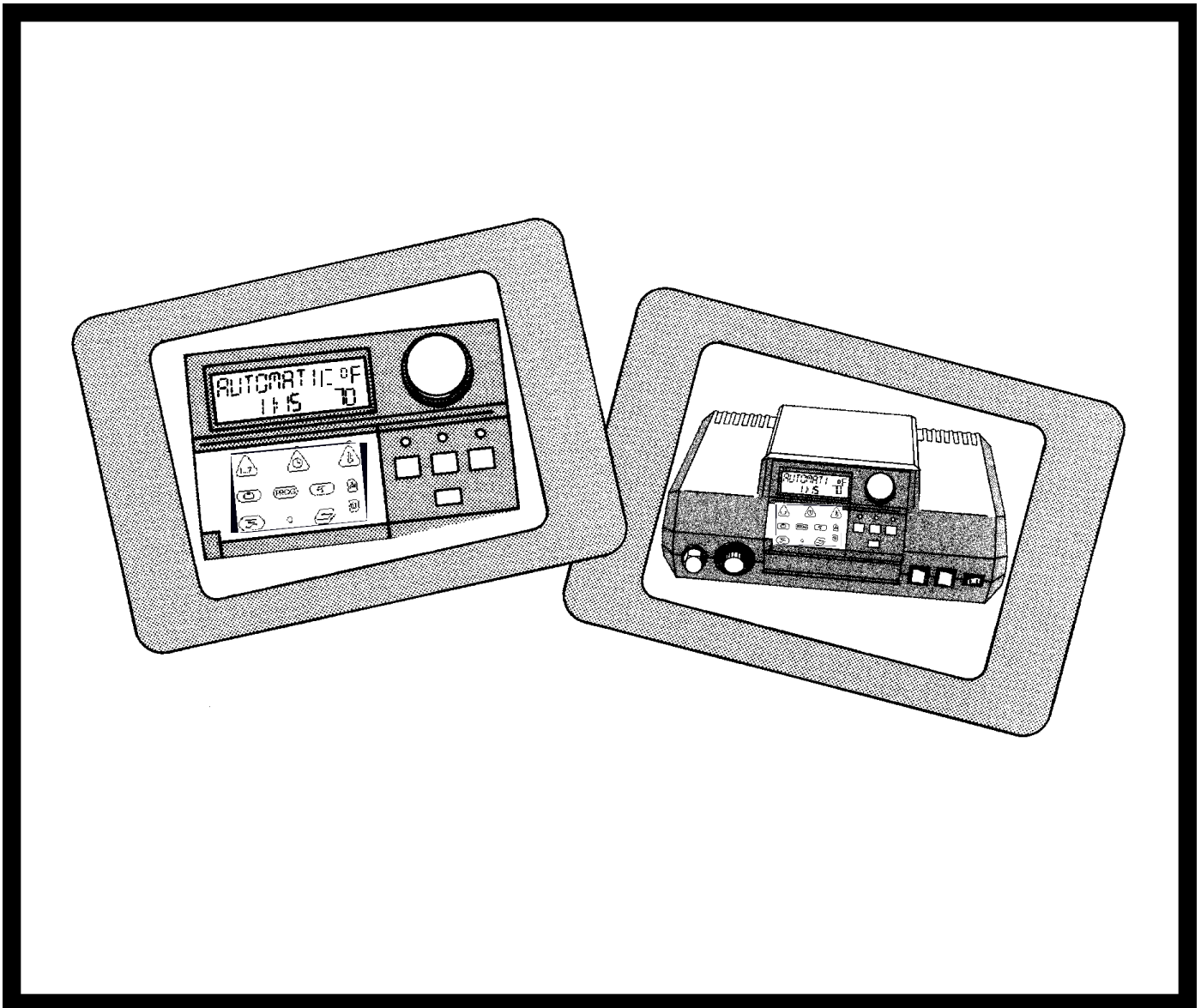

Save These Instructions !

TABLE OF CONTENTS

1	Introduction	3-4
2	Mounting Instructions	5-6
3	Testing the Manual Reset High Limit (STB)	7
4	Key Code	8
5	Program Overview and Description of the Installation Level Entry Process	9-10
6	Installation Entries	11-30
7	Display of Heating Curve(s)	31
8	Testing of Relays	32
9	LCD Test	33
10	Total System Reset	34
11	Version Number	35
12	Trouble Shooting Procedures	36
13	Parameter Settings at the Installation Level	37
14	Sensor Curves	38-39
15	Wiring Diagrams	40-46

Brief Description of Control Operation

The HS2105 is a heating system controller integrating the functions of space heating on outdoor reset using an outdoor sensor, priority domestic hot water heating (DHW) of an indirect fired water heater, periodic operation of a DHW recirculation pump as well as offering programmable night setback for customized operation. Optional modules provide 2-stage or dual burner control and outdoor reset control of a motorized mixing valve for floor heating applications.

Note: Buderus Hydronic Systems, Inc. strongly recommends the use of a thermostatic valve on the outlet of the DHW storage tank to prevent scalding when operating the HS2105 in manual override mode.

Two different control methods can be utilized with respect to space heating. Parameters listed in bold are set on the control. Refer to relevant sections in this manual for more details.

Case 1: All heating zones are controlled by on/off thermostats.

The space heating operates along a heating curve; figure 1 shows a typical curve. The slope is set by the “**REF TEMP**” value; the heating curve can be shifted up or down with the “**OFFSET**”. The boiler maintains temperature within the dashed lines of the burner differential. The control uses the difference between the specified “**DAY TEMP**” and “**NIGHT TEMP**” values to compute a lower heating curve for night mode operation.

On a call for DHW, the control can fire the burner up to the “**MAX TEMP 1**” setting for maximum recovery. The control temporarily interrupts pump operation with the burner running when the boiler water temperature drops below the “**PUMPLOGIC**” setting for condensation protection.

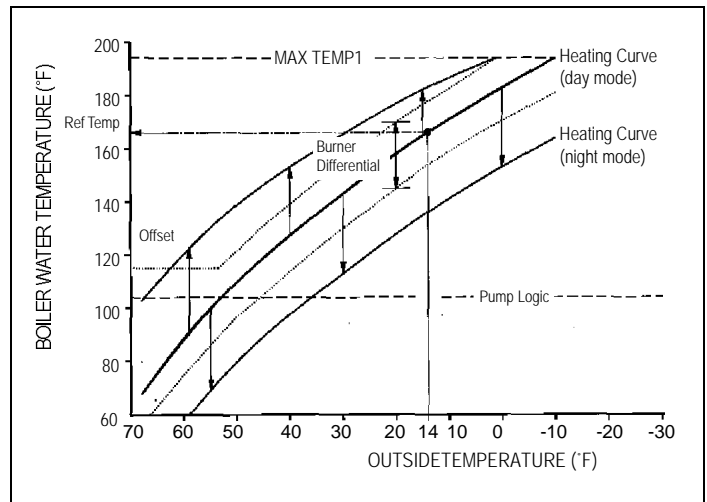

Fig. 1: Typical heating curves for the HS2105 without a room sensor

1 Introduction

Case 2: Multiple zones with the main zone on constant circulation

The heating curve is set in a similar way as in Case 1. A room sensor is required in the constant circulation zone to provide room temperature compensation for fine-tuning of the heating curve. The main zone sets the water temperature available to all secondary zones. Specified day and night temperatures on the room sensor are used internally to compute a heating curve during night mode.

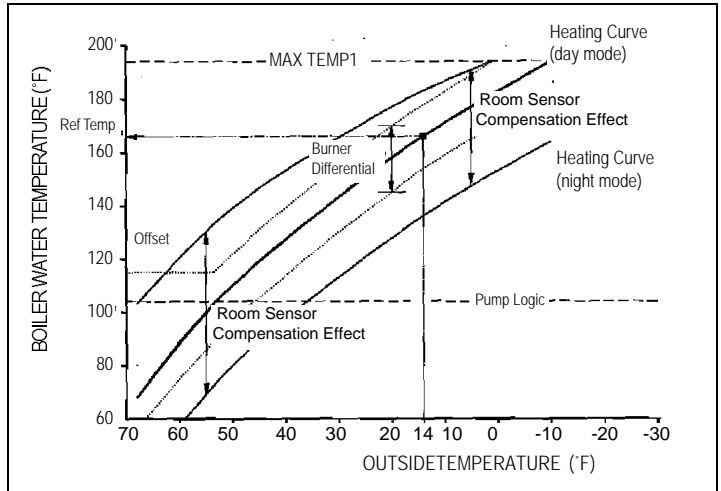

Fig. 2: HS2105 heating curve with room sensor adjustment

Case 3 : Multiple Temperatures

The heating curve for the high temperature zone(s) is set on **CIRCUIT 1**. **CIRCUIT 2** defines the low temperature heating curve using a motorized mixing valve.

The HS2105 control positions the mixing valve based on the outside and supply temperature measured by a strap-on sensor. Each heating circuit can be equipped with an optional room sensor.

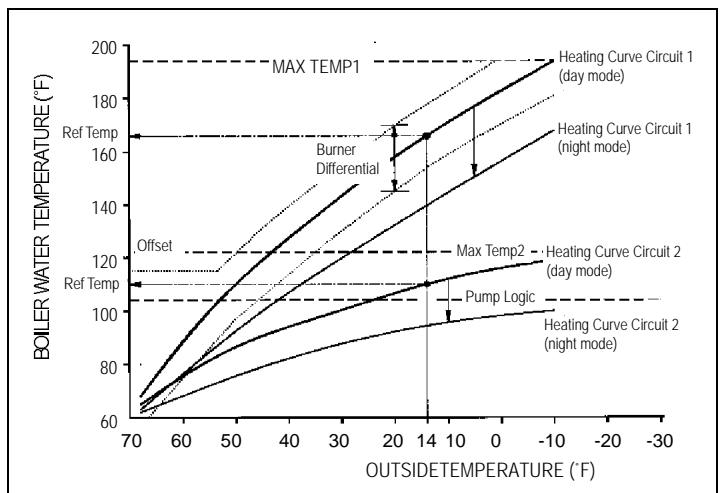
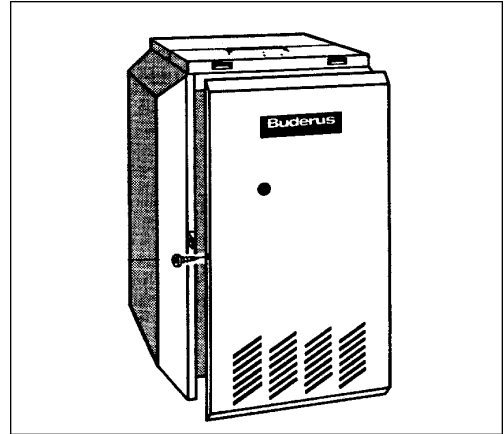
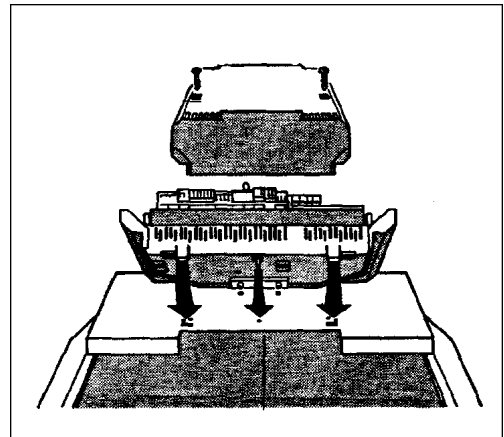

Fig.3: High and low temperature heating curves; requires module FM241

- Remove the front panel of the boiler.
- Only necessary with the G124X, G224E, G234X and G334X boilers.



- Remove the two screws and housing from the top of the Ecomatic.
- Insert the two front feet of the control into the holes provided on the top of the boiler. Then, firmly push down on the rear of the control until it snaps into place.



- Fasten the control to the boiler jacket using the two screws as shown.

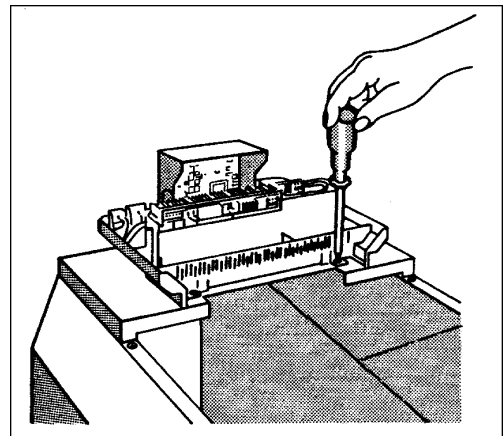

- The sensor bundle consists of one thermistor (FK), two capillaries and a spacer. Mount the sensors per the following boiler specific instructions. The chrome well is supplied with the Ecomatic.

G115, G205, G305: Replace brass well with chrome Ecomatic well. The sensor bundle must be fully inserted into the Ecomatic well.

G124X: Unwrap the sensor bundle. Remove spacers from the chrome well on the boiler. Remove the copper sleeve from one of the capillaries. Install all 3 probes in with the Honeywell capillary.

G224E/G234X/G334X: The tridicator assembly should be moved to the supply piping and replaced with the chrome plated Ecomatic well. The sensor bundle must be inserted into this well.

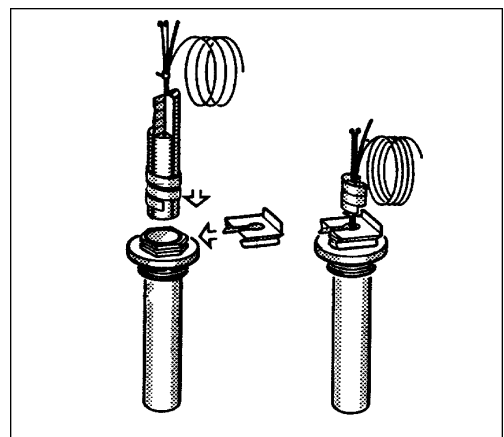

2 Mounting Instructions

- Electrical connections must be made according to the wiring diagram (See pages 40-46).
- All the wires should be routed through the cable raceway at the rear of the boiler. Rear panel jacket may be modified per local code. Route the wires on top of the insulation to the back of the control.

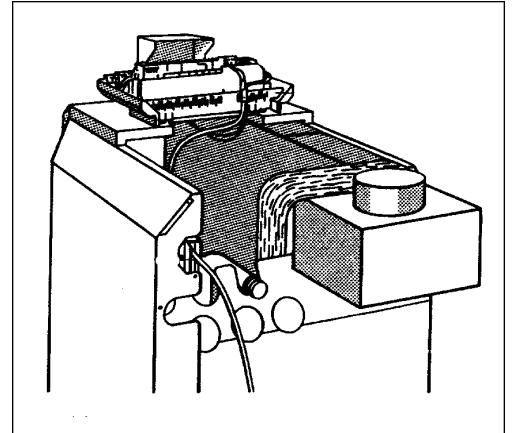

- Use the white strain reliefs provided to lock all cables into place on the back of the control.

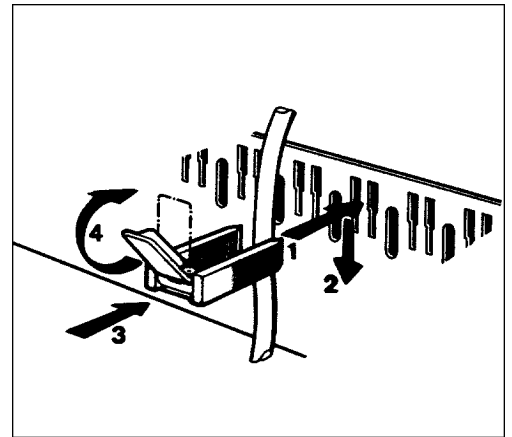

- Tilt the display to the desired position.

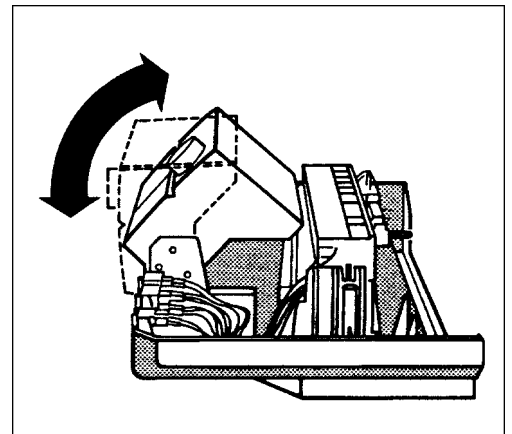

- Replace the top housing of the control and fasten the two screws. The control is ready to be placed into operation.

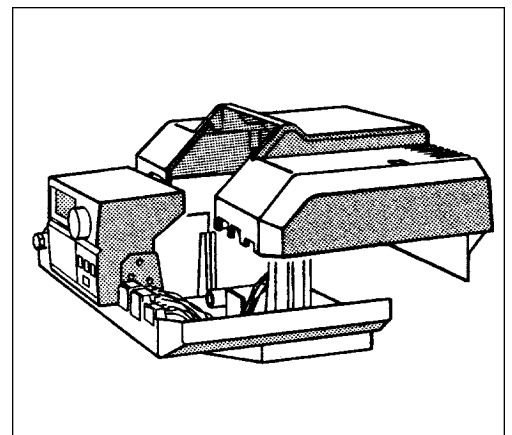

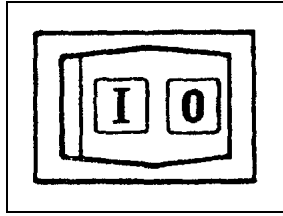

1. Switch the control on with the main power switch (I Position).

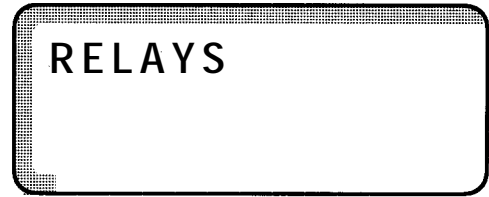

2. Enter the key code (See page 8).

3. Turn the dial until "RELAYS" appears in the display.



4. Press and hold the  button. Turn the dial until the display shows "BURNER ON". The burner starts. Heating pumps will not run during the burner test. Allow the burner to run until burner shuts off at the setpoint on the aquastat dial.



5. Remove the black aquastat dial.

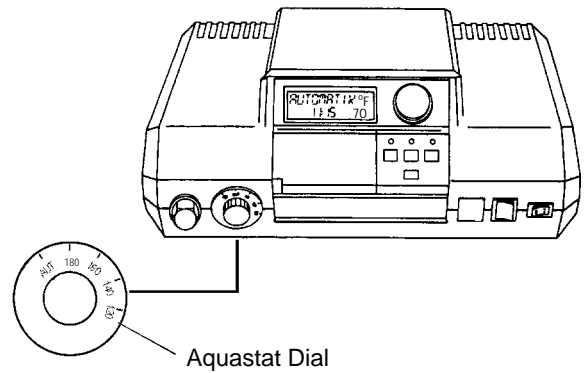

6. Push the green button in with screwdriver or similar instrument to bypass the adjustable boiler aquastat. Hold the green button until the STB or manual reset high limit trips. This happens at approximately 230°F.

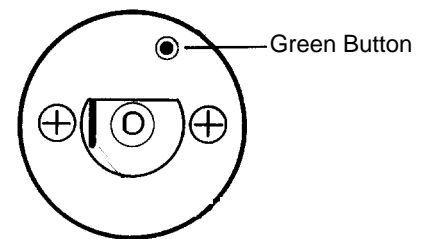

7. Run circulators to remove excess heat. Then, to reset the STB, remove the safety nut. Press in the reset button underneath. This will return the control back to normal operation.

To Resume Normal Operation:

Press the AUT button.

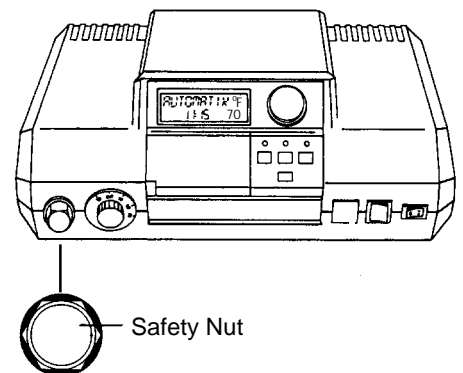

4 Key Code



Key Code

The access to the installation level of the HS2105 control is protected against unauthorized use by a special key code. Entry in this level allows you to change settings described in this manual.

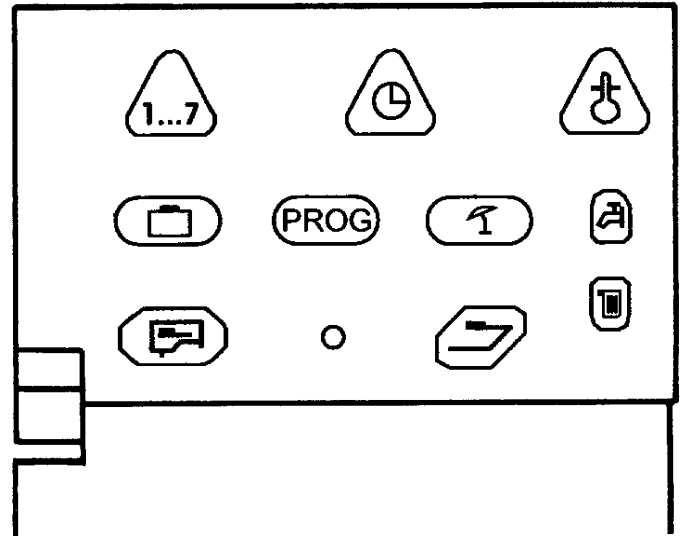
This installation level should only be accessed by a heating contractor or a trained operator. Entries at this level identify to the control the different components of the heating system, specify how these components are to be operated and set up the proper heating curve(s). These entries in general do not require any adjustment. Any adjustments must be performed by a heating contractor or a trained operator.



Key Code Access Procedure for access to the Installation Level

- Press and hold the lower left hand ENTER  button.
- Insert a pointed object into the hole directly to the right of the ENTER  button.
- Release both buttons. The display reads "DEUTSCH" (GERMAN).



To change the language selection:

- Enter the key code. The word "DEUTSCH" (GERMAN) appears in the display.
- Press and hold the  button.
- Turn the dial to select the "AMERICAN" language selection.



Returned to the Standard Display:

- Press the AUT button.

Note: The control resumes automatic operation if no entries are made for a period of 5 minutes.

The Installation level consists of a maximum of 12 main menus. Each main menu addresses a specific set of features of a certain component of the heating system. These features are contained in submenus. Most values are changed at the submenu level, not at the main menu level.

Moving around the Main Menu

- The key code allows access to the main menus.

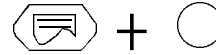



- To access different menus, turn the dial.

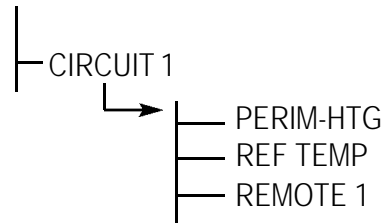

- To access a submenu, press and release the  button from the main menu.

- To move about that specific submenu and review the specific entries, turn the dial. Each entry in that specific submenu appears now in the display as the dial is turned.



- To change the value of a specific entry in the submenu, first get that entry in the display by turning the dial, then push and hold the  button. The display shows the specific entry blinking with its current value. Turn the dial to select the desired value. Release the  button. This will save the new value.

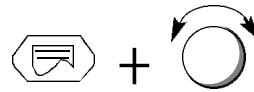

- To move to the next entry in this specific submenu, turn the dial.

- To move back to the main menu, press and release the RETURN  button.

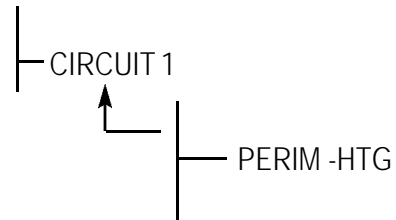

- To return to the standard display, press and release the AUT button.

Note : The HS2105 control automatically goes back to the standard display if no entries are made within five minutes.

Notice: A number of entries will only appear when their corresponding modules are inserted in the control. These modules and their functions are:

Module FM241: Mixing valve control module.

Module FM242: Two stage firing control module.

Module KM271: Communications module. Currently not available in the U.S.A.

When any of these modules are installed, the HS2105 control automatically recognizes them and releases access to the corresponding menus, submenus and their entries.

5 Program Overview

Listing of Entries at the Installation Level

Access to the installation is done using the key code.

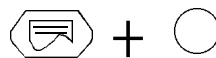

Display Read-out

	Page	
DEUTSCH	8	Language selection
BLR TEMP	9	Boiler parameters
— FREEZTEMP	11	Frost protection temperature
— BLDG RESP	12	Building heat storage capacity
— TWO STAGE*1	13	Burner operation details
— MIN MOD*2	14	Minimum firing rate for a modulating burner *2
— MOD TIME*2	15	Modulation time for full mod burner*2
— PUMPLOGIC	16	Water temperature setting for Pumplogic
— MAX TEMP1	17	Maximum electronic high limit for boiler temperature
— FLUE TEMP*3	18	Flue gas warning temperature*3
CIRCUIT 1	19	Heating Zone 1 Installation Parameters (unmixed zone)
— PERIM-HTG	19	Identifies nature of high temp zone (baseboard, radiators etc.)
— REF TEMP	20-21	Reference Temperature for specifying boiler zone reset curve
— REMOTE 1	25	Room sensor present for unmixed zone yes/no
— ROOM COMP*4	26	Room temperature compensation*4
— OASETBACK	27-28	Setback mode selection
— OFFSET	22	Offset, vertical shift of reset curve
CIRCUIT 2	19	Heating Zone 2 Installation Parameters (mixed zone)*5
— FLOOR-HTG	19	Identifies nature of low temperature mixed zone
— REF TEMP	20-21	Reference Temperature for specifying boiler zone reset curve
— DHWPRIOR	23	DHW priority on mixed zone*6
— MAX TEMP2	24	Maximum electronic high limit for mixed zone
— REMOTE 2	25	Room sensor present for mixed zone yes/no
— ROOM COMP*4	26	Room temperature compensation*4
— OASETBACK	27-28	Setback mode selection
— OFFSET	22	Offset, vertical shift of reset curve
DHWPROD	29	Domestic hot water yes/no
RECIRPUMP	30	DHW recirculation pump
HTGCURVE 1	31	Heating curve for unmixed zone
HTGCURVE 2	31	Heating curve for mixed zone
RELAYS	32	Relay test on different system components
— BURNER		Burner Relay
— BURNER 2*1), MOD BNR*2)		Burner 2 Relay*1), Modulation higher/lower*2)
— HTG1 PUMP		Boiler zone pump (unmixed heating circuit)
— HTG2 PUMP		Mixed zone pump (mixed heating circuit)
— MIXVALVE*5)		Mixing valve open/close*5)
— DHW PUMP*6)		Tank charging pump*6)
— RECIRPUMP*6)		DHW recirculation pump*6)
LCD- TEST	33	LCD test
RESET	34	General system reset to factory settings
VERSION	35	Control version number

*1 Applies only with module FM 242 installed and 2 stage burner selected.

*2 Applies only with module FM 242 installed and modulating burner selected.

*3 Applies only with module KM 271.

*4 Applies only with remote sensor installed.

*5 Applies only with Module FM 241 installed.

*6 Applies only with domestic hot water installed.

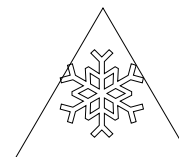

Freeze Protection: “FREEZTEMP”

To prevent the heating system from freezing, the control will automatically permit the heating circulators to run continuously in the night mode when the outside temperature drops below the “FREEZTEMP” value irrespective of the selected setback mode.



The factory setting is 41°F; the range is 0°F to 50°F.

To change the FREEZTEMP:

- Enter the key code.
- Turn the dial until the word “BLR TEMP” appears in the display.
- Press the  button and release. The display will show “FREEZTEMP”.
- Press and hold the  button. The current value of the “FREEZTEMP” is blinking.
- Turn the dial until the desired “FREEZTEMP” value appears in the display.



Return to the main menu:

- Press the  return.

RETURN TO THE STANDARD DISPLAY:

- Press the AUT button.

Note: The control resumes automatic operation if no entries are made for a period of five minutes.

Note 1: The “FREEZTEMP” setting is the determining value when using the “OASETBACK” setback mode. The circulators will not operate in night mode when the outside temperature exceeds the “FREEZTEMP” value. The circulators will run constantly for outside temperatures below the “FREEZTEMP” value.

Note 2: The “FREEZTEMP” setting is also of significance in terms of pump operation during the night mode when using room sensors. The heating circulators (on circuits 1 and 2) will stop when the actual room temperature exceeds the desired night temperature AND the outside temperature exceeds the “FREEZTEMP” value.

	Range	Factory Setting	Current Setting
Freeze Protection: “FREEZTEMP”	0°F to 50°F	41°F	

6 Installation Entries

Building Type: “BLDG RESP”



The type of building in terms of insulating factor, heat storing capacity and response to outside temperature changes is specified with the “BLDG RESP” setting.

The HS2105 control uses this setting to respond in a delayed fashion to changes in outside temperature and relies on the heat storing capacity to maintain a comfortable temperature level in the building. The settings are defined as:

- 1= Buildings with small heat storing capacity and medium levels of insulation (Wood construction and medium to heavy insulation).
- 2= Buildings with medium heat storing capacity and high levels of insulation (Brick construction with medium insulation).
- 3= Buildings with high heat storing capacity and high levels of insulation (Heavy brick construction with good insulation).

Note: For areas where rapid changes in outside temperatures occur, it is recommended to always use setting 1 irrespective of the type of construction.

To change the “BLDG RESP” setting:

- Enter the key code.
- Turn the dial until the word “BLR TEMP” appears in the display.
- Press the  button and release. The display will show “FREEZTEMP”.
- Turn the dial until the word “BLDG RESP” appears in the display.
- Press and hold the  button.
The current value of the “BLDG RESP” setting is blinking.
- Turn the dial until the desired “BLDG RESP” value appears in the display.

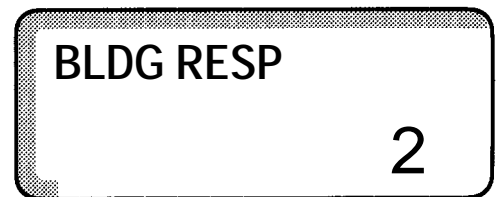

Return to main menu:

- Press the  button.

RETURN TO THE STANDARD DISPLAY

- Press the AUT button.

	Range	Factory Setting	Current Setting
Freeze Protection: “FREEZTEMP”	1,2,3	2	



Burner Installation: “BURNER”

The burner module FM242 must be installed for this submenu to appear. The factory setting without the FM242 module is “ONE STAGE”. However, this setting does not become visible in the display when module FM242 is not installed.

The HS2105 control automatically switches from single stage to two stage when the FM242 module is inserted. One can select at this point between a one stage burner, two stage burner (or dual boiler/burner system) or modulating burner.

Note: In case a two stage burner (or dual boiler system) is selected, separate burner run times will be displayed.

To change the “ BURNER” setting:

- Enter the key code.
- Turn the dial until the word “BLR TEMP” appears in the display.
- Press the  button and release.
The display will show “FREEZTEMP”.
- Turn the dial until the word “TWO STAGE” appears in the display.
- Press and hold the  button.
The adjustable parameter is blinking.
- Turn the dial until the word “MOD BRNR” appears in the display for a modulating burner.

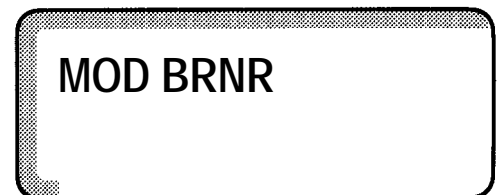

Return to main menu:

- Press the  button.

RETURN TO THE STANDARD DISPLAY

- Press the AUT button.

	Range	Factory Setting	Current Setting
Burner System without FM242 module		1-stage	
Burner System with FM242 module	1-stage/2-stage/modulating	2-stage	



6 Installation Entries

Minimum Firing Rate for a Modulating Burner: “MIN MOD”

The installation of the burner module FM242 and the selection of a modulating burner (“MOD BRNR”) are required in order for this submenu to appear. The minimum firing rate of the burner modulation is specified in this setting.

The factory setting is 30%.

To change the “MIN MOD” setting:

- Enter the key code.
- Turn the dial until the word “BLR TEMP” appears in the display.
- Press the  button and release.
The display will show “FREEZTEMP”.
- Turn the dial until the word “MIN MOD” appears in the display.
- Press and hold the  button.
The current value of the “MIN MOD” is blinking.
- Turn the dial until the desired “MIN MOD” value appears in the display.

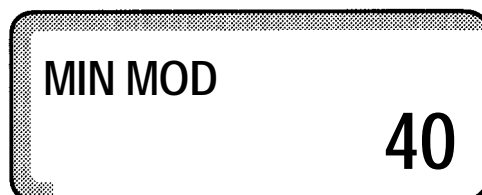
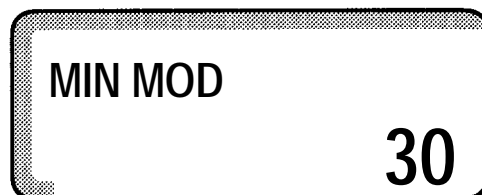

Return to main menu:

- Press the  button.

RETURN TO THE STANDARD DISPLAY

- Press the AUT button.



	Range	Factory Setting	Current Setting
Minimum Modulation “MIN MOD”	10% to 60%	30%	

Modulating Valve Operating Time for the Modulating Burner: “MOD TIME”

The installation of the burner module FM242 and the selection of a modulating burner (“MOD BRNR”) are required in order for this submenu to appear. The modulating valve operating time is the total time in seconds required for the modulating burner to go through its full operating range.

The factory setting is 12 seconds.

To change the “MOD TIME” setting:

- Enter the key code.
- Turn the dial until the word “BLR TEMP” appears in the display.
- Press the  button and release.
The display will show “FREEZTEMP”.
- Turn the dial until the word “MOD TIME” appears in the display.
- Press and hold the  button.
The current value of the adjustable parameter is blinking.
- Turn the dial until the desired valve operating time
“MOD TIME” appears in the display.



Return to main menu:

- Press the  button.

RETURN TO THE STANDARD DISPLAY

- Press the AUT button.

	Range	Factory Setting	Current Setting
Valve Operating Time “MOD TIME”	5 sec - 60 sec	12 sec	



6 Installation Entries

Condensate Protection Feature: “PUMPLOGIC”

The HS2105 control has a built in feature called “PUMPLOGIC” where the control interrupts circulator operation when the burner fires into a cold boiler. Once a specified temperature is reached in the boiler, the pumps are permitted to run. This temperature is adjustable and set with the “PUMPLOGIC” setting.

The factory setting is: 104°F for a one stage burner
 113°F for a two stage burner
 122°F for a modulating burner

To change the “PUMPLOGIC” setting:

- Enter the key code.
- Turn the dial until the word “BLR TEMP” appears in the display.
- Press the  button and release.
The display will show “FREEZTEMP”.
- Turn the dial until the word “PUMPLOGIC” appears in the display.
- Press and hold the  button.
The current value of “PUMPLOGIC” is blinking.
- Turn the dial until the desired value for “PUMPLOGIC” appears in the display. Consult the table below for your boiler model.

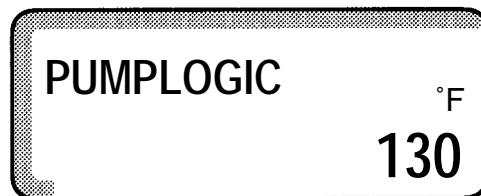
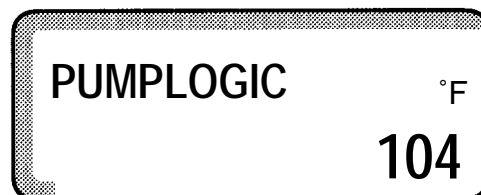



Table 1: Minimum “PUMPLOGIC” values

Boiler Series	1 - STAGE	2 - STAGE	MODULATING
G115,G205, G305	104	N/A	N/A
G315	122	131	131
G515	122	131	131
G124X	104	N/A	N/A
G234X/G334X	104	122	N/A

Note: The minimum burner shut-off temperature always exceeds the “PUMPLOGIC” value by 9°F.

Return to main menu:

- Press the  button.

RETURN TO THE STANDARD DISPLAY

- Press the AUT button.

Note: The control resumes automatic operation if no entries are made for a period of five minutes.



	Range	Factory Setting	Current Setting
Pump Shut-off Temp. “PUMPLOGIC”	59-140°F	104°F	

Maximum Burner Shut-off Temperature: “MAX TEMP1”

A maximum temperature is specified above which the electronic boiler sensor shuts off the burner. This setting is not operative when the control is operating in the manual mode using the emergency override switch. The adjustable capillary high limit shuts off the burner in manual override mode.

The factory setting is 176°F.

To change the “MAX TEMP1” setting:

- Enter the key code.
- Turn the dial until the word “BLR TEMP” appears in the display.
- Press the  button and release.
The display will show “FREEZTEMP”.
- Turn the dial until the word “MAX TEMP1” appears in the display.
- Press and hold the  button.
The current value of “MAX TEMP1” is blinking.
- Turn the dial until the desired value for “MAX TEMP1” appears in the display.

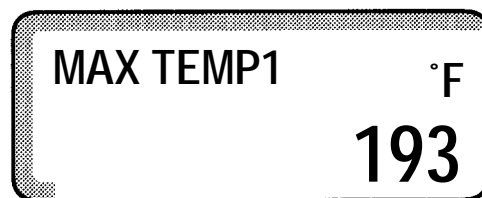
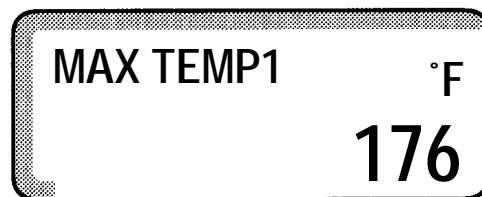

Return to main menu:

- Press the  button.

RETURN TO THE STANDARD DISPLAY

- Press the AUT button.

	Range	Factory Setting	Current Setting
Maximum Boiler Shut-off Temperature	158 - 210°F	176°F	

6 Installation Entries



Flue Gas Temperature Sensing: “FLUE TEMP ”

Module KM271 must be installed for this submenu to appear. The flue gas temperature can only be measured and shown in the display when the KM271 module is installed in the HS2105 control. The flue gas temperature can be viewed in the display.

When an ECOKOM communication system and modem is installed, a service message is transmitted when the flue gas temperature exceeds a preset value. The boiler will require maintenance. The flue gas sensing capability must be activated when the KM271 module has been installed.

The factory setting is “OFF”.

To change the “FLUE TEMP” setting:

- Enter the key code.
- Turn the dial until the word “BLR TEMP” appears in the display.
- Press the  button and release.
The display will show “FREEZTEMP”.
- Turn the dial until the word “FLUE TEMP” “OFF” appears in the display.
- Press and hold the  button.
The adjustable parameter is blinking.
- Turn the dial until the desired flue gas temperature is shown in the display above which a service message would be transmitted.

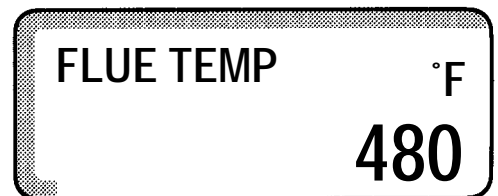
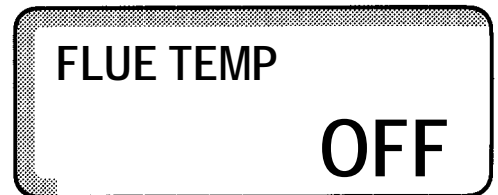

Return to main menu:

- Press the  button.

RETURN TO THE STANDARD DISPLAY

- Press the AUT button.

Note : The control resumes automatic operation if no entries are made for a period of 5 minutes.

	Range	Factory Setting	Current Setting
Flue Gas Temperature “FLUE TEMP”	OFF/120-480°F	OFF	

Heating System Lay-out

The HS2105 control is designed for individual control of two heating circuits with different water temperatures. The second heating circuit is only possible when the mixing module FM241 has been installed. The nature of each heating circuit must be specified to the control. For example, baseboard heating on circuit 1 and radiant floor heating on circuit 2. The HS2105 control needs this information to set the proper curvature for the different heating curves.



Circuit 1 Options:

- “PERIM-HTG” Circuit 1 operates on a reset curve for perimeter heating such as baseboard or radiators (Range 86°F-194°F).
- “NO SYSTEM” Circuit 1 follows circuit 2 reset curve. This option can only be selected when module FM241 is installed. The boiler operates 9°F above the circuit 2 requirements.

Circuit 2 Options:

- “PERIM-HTG” Circuit 2 operates on reset curve for perimeter heating (Range 86°F-194°F).
- “FLOOR-HTG” Circuit 2 operates on a reset curve suitable for radiant floor heating (Range 86°F-140°F).
- “NO SYSTEM” Circuit 2 follows the same reset curve as specified for circuit 1.

To change the heating circuit descriptions:

- Enter the key code.
- Turn the dial until the word “CIRCUIT 1” or “CIRCUIT 2” appears in the display.
- Press the  button and release. The display will show “PERIM-HTG”.
- Press and hold the  button. The adjustable parameter is blinking.
- Turn the dial until the desired heating circuit description appears in the display.

Return to main menu:

- Press the  button.

Note: In case module FM241 is installed, repeat the “Turn the dial” step until the word “CIRCUIT 2” appears in the display. Repeat the steps above to properly define circuit 2.

RETURN TO THE STANDARD DISPLAY

- Press the AUT button.

	Range	Factory Setting	Current Setting
CIRCUIT 1	PERIM-HTG/NO SYSTEM	PERIM-HTG	
CIRCUIT 2	PERIM-HTG/FLOOR-HTG/NO SYSTEM	FLOOR-HTG	

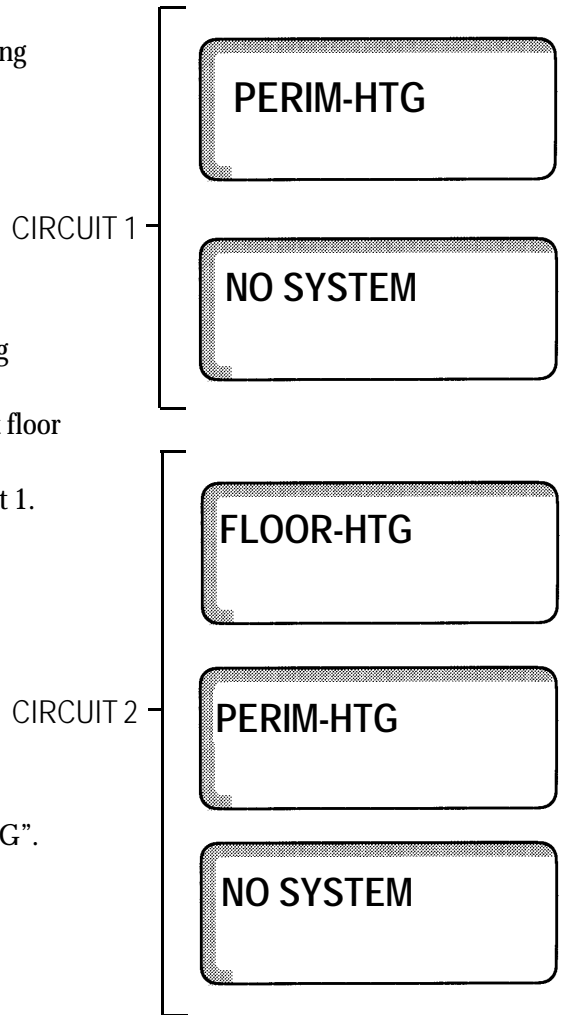

6 Installation Entries

Heating Curve Selection: Setting the Reference Temperature

The heating curve establishes the relationship between the outside air and boiler water temperatures. The boiler water is automatically lowered at warmer outside temperatures and raised at colder outside temperatures.

The correct heating curve is determined by the characteristics of the house (i.e., type of radiation, degree of insulation, heating system design temperatures, etc.) Baseboard systems are generally designed to operate at 190°F on design day. The figure below shows a number of heating curves for different design temperatures.



To select the proper curve, one must always specify the desired water temperature for an outside temperature of 14°F. The corresponding water temperature is the "REF TEMP" setting. The HS2105 control then automatically creates a curve for all outside temperatures.

Heating Curve Adjustments

The "REF TEMP" fine adjustment should be done based on cold weather performance. Increase the "REF TEMP" value if the room temperature is too low during cold weather. Decrease the "REF TEMP" setting if overheating tends to occur. Make only minor adjustments and allow ample time for the system to respond.

Example: "REF TEMP" Selection:

Assume a panel radiator is designed with a maximum water temperature of 176°F for a -20°F design day. Locate the point where 176°F water temperature intersects -20°F outside temperature. Draw a curve from this point to the starting point (68°). Now enter the chart at the 14°F point and move vertically until you intersect your curve. Now move horizontally to the left to find your "REF TEMP". In this case it would be approximately 142°F.

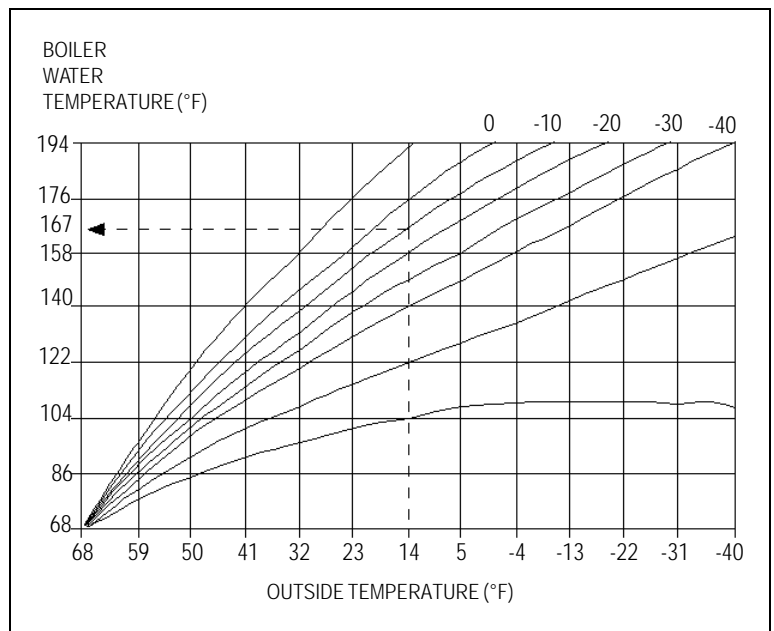



Heating Curve Selection: Setting the “REF TEMP”

The “REF TEMP” setting is adjustable from 86°F to 194°F. The slope of the heating curve changes as the “REF TEMP” value is changed.

The factory setting is 167°F for “PERIM-HTG” circuits and 113°F for “FLOOR-HTG” circuits.

To change the “REF TEMP” settings

- Enter the key code.
- Turn the dial until the word “CIRCUIT 1” or “CIRCUIT 2” appears in the display.
- Press the  button and release.
The display will show “PERIM-HTG” or “FLOOR-HTG”.
- Turn the dial until the word “REF TEMP” appears in the display.
- Press and hold the  button.
The current value for “REF TEMP” is blinking.
- Turn the dial until the desired value for “REF TEMP” appears in the display.

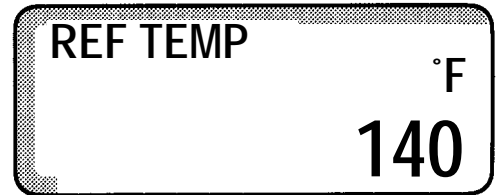
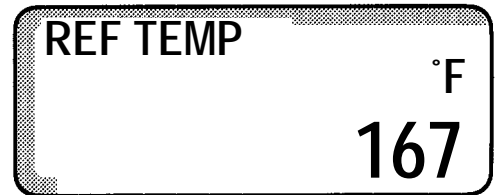

Return to main menu:

- Press the  button.

RETURN TO THE STANDARD DISPLAY

- Press the AUT button.
- Repeat above procedure for “CIRCUIT 2” if module FM241 is installed.

Note: The control resumes automatic operation if no entries are made for a period of 5 minutes.

Note: In case the maximum design temperature for the radiant floor system exceeds 140°F, you must select “PERIM-HTG” for circuit 2 to reach sufficiently high water temperatures.

	Range	Factory Setting	Current Setting
“REF TEMP” for “PERIM-HTG”	86°F - 194°F	167°F	
“REF TEMP” for “FLOOR-HTG”	86°F - 140°F	113°F	



6 Installation Entries

Vertical Shifting of the Heating Curve: “OFFSET”

The “OFFSET” entry can be used to parallel shift a heating curve upward or downward. Every + 1 °F adjustment in the “OFFSET” results in a +2 or +3 °F increase in water temperature. A maximum upshift in water temperature of approximately 25 to 30 °F is achieved with the “OFFSET” equal to +9 °F (see Fig. 1 on page 3).

The factory setting is 0.

To change the “OFFSET” value:

- Enter the key code.
- Turn the dial until the word “CIRCUIT 1” or “CIRCUIT 2” appears in the display.
- Press the  button and release.
The display will show “PERIM-HTG” or “FLOOR-HTG”.
- Turn the dial until the word “OFFSET” appears.
- Press and hold the  button.
The current value of “OFFSET” is blinking.
- Turn the dial until the desired value for “OFFSET” is shown in the display.

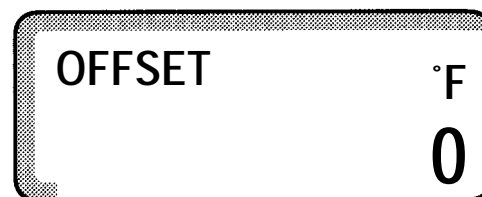

Return to main menu:

- Press the  button.

RETURN TO THE STANDARD DISPLAY

- Press the AUT button.

Note: The control resumes automatic operation if no entries are made for a period of 5 minutes.

	Range	Factory Setting	Current Setting
“OFFSET” value for Circuit 1	-9°F - 9°F	0°F	
“OFFSET” value for Circuit 2	-9°F - 9°F	0°F	



Domestic Hot Water Priority for Circuit 2 : “DHW PRIOR”

The HS2105 control automatically grants domestic hot water (DHW) priority over heating circuit 1. In other words, on a call for domestic hot water, the control temporarily shuts off the circulator for heating circuit 1, fires the burner and runs the tank circulator.

If Module FM241 is installed in the control, one can select whether to have DHW priority over circuit 2 or to operate circuit 2 in parallel. If DHW priority over circuit 2 is selected, the mixing valve closes during heating of domestic hot water. If parallel operation is desired, the mixing valve continues operation and longer DHW heating times can be expected.

The factory setting for “DHW PRIOR” is “ON”.

To change the “DHW PRIOR” setting:

- Enter the key code.
- Turn the dial until the word “CIRCUIT 2” appears in the display.
- Press the  button and release. The display will show “NO SYSTEM”, “PERIM-HTG” or “FLOOR-HTG”.
- Turn the dial until the words “DHW PRIOR” “OFF” appear.
- Press and hold the  button. The current value is blinking.
- Turn the dial until the desired value is shown in the display.

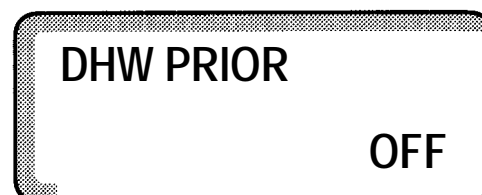
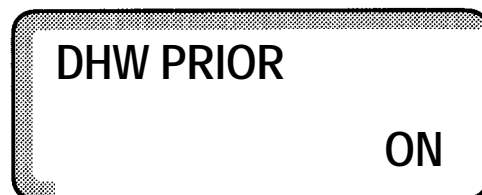

Note: The DHW setting in the main menu must be turned “ON” in order for the above submenu to appear.

Return to main menu:

- Press the  button.

RETURN TO THE STANDARD DISPLAY

- Press the AUT button.

Note: The control resumes automatic operation if no entries are made for a period of 5 minutes.

	Range	Factory Setting	Current Setting
“DHW PRIOR” (for Circuit 2 only)	ON/OFF	ON	



6 Installation Entries

Maximum Heating Circuit 2 Temperature: “MAX TEMP2”

The maximum temperature in heating circuit 2 is specified in “MAX TEMP2” and shall not exceed this value.

The factory settings for circuit 2 are: for “PERIM-HTG” 194°F
 for “FLOOR-HTG” 122°F

To change the “MAX TEMP2” setting:

- Enter the key code.
- Turn the dial until the word “CIRCUIT 2” appears in the display.
- Press the  button and release.
 The display will show “PERIM-HTG” or “FLOOR-HTG”.
- Turn the dial until the word “MAX TEMP2” appears in the display.
- Press and hold the  button.
 The current value of “MAX TEMP2” is blinking.
- Turn the dial until the desired value is shown in the display.

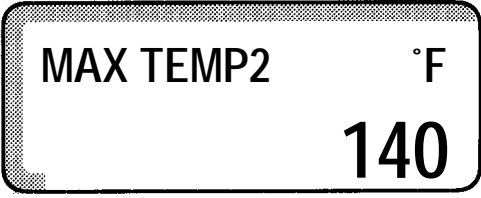
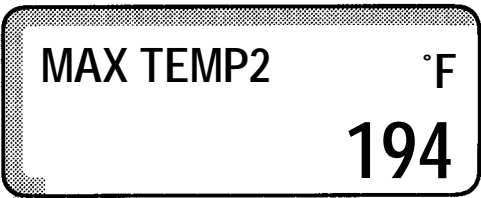

Return to main menu:

- Press the  button.

RETURN TO THE STANDARD DISPLAY

- Press the AUT button.

Note: The control resumes automatic operation if no entries are made for a period of 5 minutes.

	Range	Factory Setting	Current Setting
Max Temperature for Circuit 2 PERIM – HTG	68°F - 194°F	194°F	
Max Temperature for Circuit 2 FLOOR – HTG	68°F - 140°F	122°F	



Room Sensor: “REMOTE ”

The room sensor is an optional indoor temperature sensor which is required when using a constant circulation zone. A maximum of 2 room sensors can be installed on the system; one for a constant circulation zone for circuit 1 and one for a constant circulation zone for circuit 2. If no room sensors are installed, the system operates using only outside temperature as a reference and requires conventional thermostats to control pumps/zone valves.

The room sensor performs a correction or compensation on the boiler water temperature based on the deviation between the actual and desired room temperature. The room sensor allows setting of day temperature and night setback as well as remotely overriding the customized heating program. The room sensor also performs a “boost” during transition to day mode.

The room sensor selection must be activated for use.
The factory setting is “OFF”.

To activate the room sensor(s):

- Enter the key code.
- Turn the dial until the word “CIRCUIT 1” or “CIRCUIT 2” appears in the display.
- Press the  button and release.
The display will show “PERIM-HTG” or “FLOOR-HTG”.
- Turn the dial until the word “REMOTE 1” or “REMOTE 2” appears in the display.
- Press and hold the  button. The adjustable parameter is blinking.
- Turn the dial until the word “ON” appears in the display.

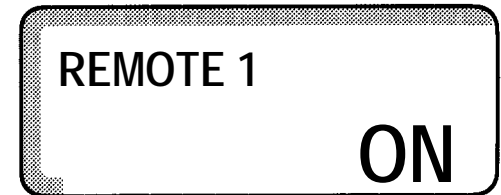
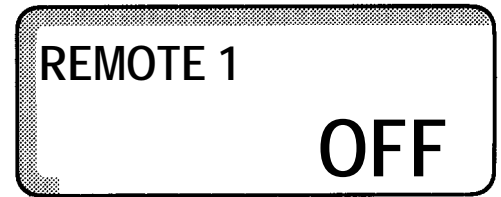

Return to main menu:

- Press the  button.

RETURN TO THE STANDARD DISPLAY

- Press the AUT button.

NOTICE: If a room sensor is installed on either circuit 1 or circuit 2, then the desired day and night temperatures can only be set on the room sensor and no longer on the HS2105 control itself. The buttons on the HS2105 itself are no longer functional for this circuit. Pressing the temperature button on the HS2105 will indicate that a room sensor is installed on the system. The buttons on the HS2105 apply now only to the heating circuit without a room sensor. The day and night temperatures are set on the HS2105 only for this circuit.

	Range	Factory Setting	Current Setting
Remote Sensor CIRCUIT 1	OFF/ON	OFF	
Remote Sensor CIRCUIT 2	OFF/ON	OFF	

6 Installation Entries



Adjusting the Room Temperature Compensation: "ROOM COMP".

The room sensor compensates for swings in room temperature (i.e. solar gain, internal heat gain, open windows) by adjusting the water temperature in its particular zone. The range of compensation is adjustable and limits the effect of the room sensor on the water temperature.

The factory setting is 5°F.

Note: When "OFF" is selected, the room sensor does not have any effect on the heating curve where it is placed. The constant circulation pump continues to operate.

To change room temperature compensation: "ROOM COMP":

- Enter the key code.
- Turn the dial until the words "CIRCUIT 1" or "CIRCUIT 2" appear in the display.
- Press the  button and release.
The display will show "PERIM-HTG" or "FLOOR-HTG".
- Turn the dial until the word "ROOM COMP" appears in the display.
- Press and hold the  button.
The current value of "ROOM COMP" is blinking.
- Turn the dial until the word "OFF" or the desired amount of "ROOM COMP" appears in the display.



Return to main menu:

- Press the  button.

RETURN TO THE STANDARD DISPLAY

- Press the AUT button.

Note: The control resumes automatic operation if no entries are made for a period of 5 minutes.

	Range	Factory Setting	Current Setting
Room compensation for CIRCUIT 1	OFF/ 1 - 18°F	5°F	
Room compensation for CIRCUIT 2	OFF/ 1 - 18°F	5°F	

Setback Mode Selection

The HS2105 control contains night setback capability and allows you to select from 4 different types or modes of night setback for customized operation. These setback modes differ in their operation during setback periods.

Night Setback Options

The factory setting is “OASETBACK”.

1 Boiler Off (“BLR OFF”)

In this mode the heating system shuts down completely during the night time as long as the outside temperature exceeds the “FREEZTEMP” setting. Below the “FREEZTEMP” value, the circulators run in freeze protection mode. The boiler only fires if the water temperature drops below 41 °F. Again, no room sensors are used when using this setback mode.

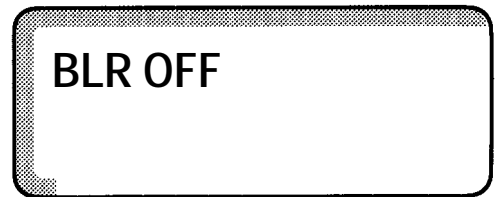

2 General Setback (“SETBACK”)

The heating circulators continue operation in the “SETBACK” mode; the boiler operates on a lower heating curve and fires the burner as needed. This mode is generally used when no room sensors are present and individual zones are controlled by conventional thermostats.

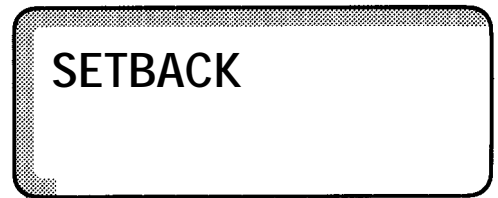

3 Room Setback (“RMSETBACK”)

This setback mode should only be selected when a room sensor is installed and activated. The system operates to maintain the desired night time temperature as specified on the room sensor. The circulators will operate continuously when the outside temperature is below the “FREEZTEMP” setting; the circulators shut down when the outside temperature is above the “FREEZTEMP” setting and the actual room temperature exceeds the night time setting.

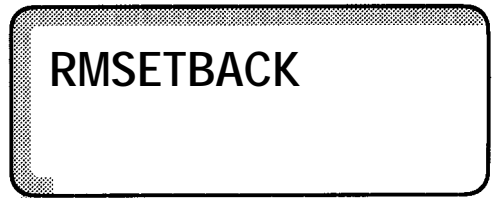

4 Outside Air Setback (“OASETBACK”)

The heating system (burner and heating circulators) shuts down in night mode if the outside temperature exceeds the “FREEZTEMP”; if the outside temperature drops below the “FREEZTEMP”, the heating system operates on a setback curve. This mode should only be used on buildings not occupied in the night mode; i.e. commercial and daytime use only buildings. A room sensor is generally not used in this application.

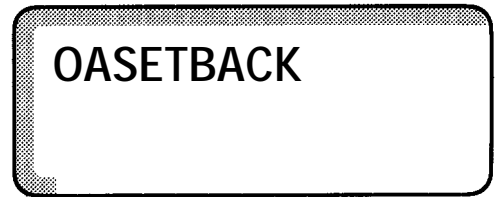



Recommended Settings:

- | | |
|--|-----------|
| Heating circuit with constant circulation zone : | RMSETBACK |
| Heating Circuit with ON/OFF thermostats: | SETBACK |
| Commercial (day use only) buildings: | OASETBACK |

6 Installation Entries

To Change the Setback Mode Setting:

- Enter the key code.
- Turn the dial until the word “CIRCUIT 1” or “CIRCUIT 2” appears in the display.
- Press the  button and release.
The display will show “PERIM-HTG” or “FLOOR-HTG”.
- Turn the dial until the word “OASETBACK” appears in the display.
- Press and hold the  button.
The adjustable parameter is blinking.
- Turn the dial until the desired setback mode appears in the display.

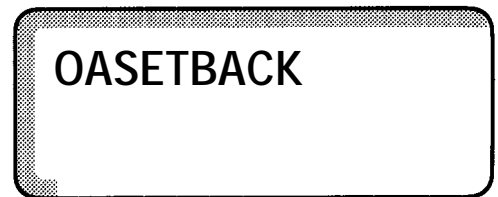

Return to main menu:

- Press the  button.

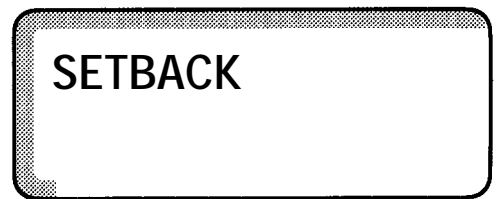

RETURN TO THE STANDARD DISPLAY

- Press the AUT button.

Note: The control resumes automatic operation if no entries are made for a period of 5 minutes.

	Range	Factory Setting	Current Setting
Setback Modes for CIRCUIT 1	OASETBACK/SETBACK/ RMSETBACK/BLR OFF	OASETBACK	
Setback Modes for CIRCUIT 2	OASETBACK/SETBACK/ RMSETBACK/BLR OFF	OASETBACK	

Domestic Hot Water Production Capability: “DHW PROD”

The HS2105 is set up to have an indirect fired water tank installed in the system. The DHW portion of the control is activated.

The factory setting is “ON”.

In case no indirect fired DHW tank is installed in the system, the DHW production must be shut off. In case the DHW is not turned off, a “DHW SENSR” error message will appear in the display because the DHW sensor is not installed.

To shut off the DHW feature of the HS2105 control:

- Enter the key code.
- Turn the dial until the word “DHW PROD” appears in the display.
- Press and hold the  button. The adjustable parameter is blinking.
- Turn the dial until the word “OFF” appears in the display.

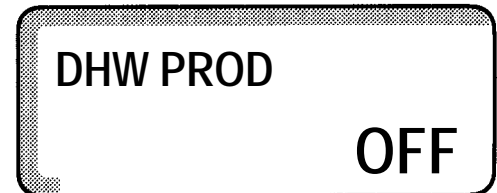
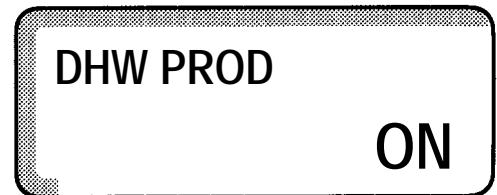

Return to main menu:

- Press the  button.

RETURN TO THE STANDARD DISPLAY

- Press the AUT button.

Note: The control resumes automatic operation if no entries are made for a period of 5 minutes.

Note: In case the DHW capability is activated, a DHW recirculation pump (if installed) can be controlled.

	Range	Factory Setting	Current Setting
DHW Capability “DHW PROD”	OFF / ON	ON	

6 Installation Entries

DHW Recirculation Pump “RECIRPUMP”

The HS2105 can operate a DHW recirculation pump for constant supply of domestic hot water at faucets. This recirc pump is simultaneously activated with the DHW production and runs concurrent with day mode operation for DHW.

This recirculation pump can be set up to operate continuously or intermittently. This pump is operational when at least one heating circuit is operating in day mode or when DHW production is in constant day mode.

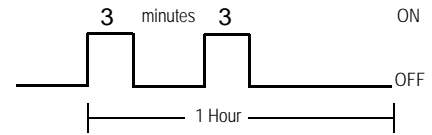

The recirculation pump operates continuously in the “ON” position.

The factory setting is 2.

A setting of 2 means that the recirculation pump runs twice every hour for a three minute interval. One can select from 1 to 6 intervals per hour for customized operation.

To change the interval run time for the recirculation pump:

- Enter the key code.
- Turn the dial until the word “RECIRPUMP” appears in the display.
- Press and hold the  button. The adjustable parameter is blinking.
- Turn the dial until the desired number of intervals per hour, “ON” or “OFF” appears in the display.

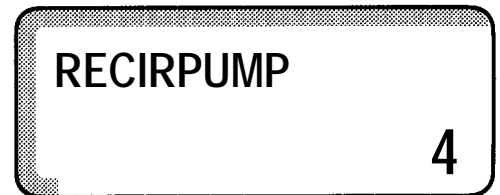

Return to main menu:

- Press the  button.

RETURN TO THE STANDARD DISPLAY



- Press the AUT button.

Note: The control resumes automatic operation if no entries are made for a period of 5 minutes.

	Range	Factory Setting	Current Setting
DHW Recirculation “RECIRPUMP”	OFF /1/2/3/4/5/6/ON	2	

The current heating curves for circuit 1 and circuit 2 (if module FM241 is installed) can be displayed by showing three water temperatures for each circuit at outside temperatures of 50°F, 32°F and 14°F based on current system settings.

To display the heating curve for circuit 1 or circuit 2:

- Enter the key code.
- Turn the dial until the word “HTG CURVE 1” or “HTG CURVE 2” appears in the display.
- Press and hold the  button.
- The first screen shows the water temperature at 50°F outside temperature, turning the dial shows the water temperature at 32°F and the third display shows the water temperature at 14°F outside temperature. Keep the  button down during these steps.

Return to main menu:

- Press the  button.

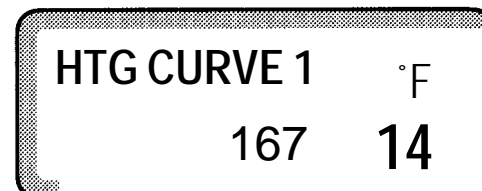
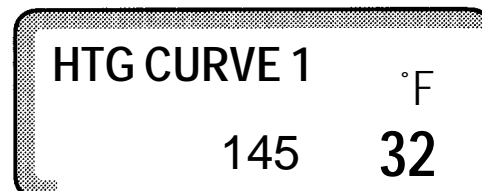
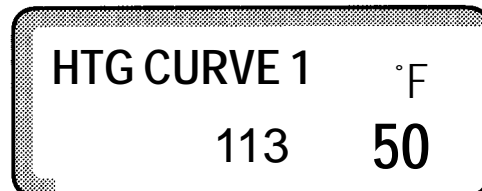

RETURN TO THE STANDARD DISPLAY

- Press the AUT button.

Note: The control resumes automatic operation if no entries are made for a period of 5 minutes.

8 Testing of Relays



Testing of All Relays of the HS2105 Control : “REL AYS”

The switching relays in the HS2105 control can individually be tested with the “RELAYS” test. This test is also useful to verify that circulators, burner(s) and mixing valve(s) are properly wired to the control. The actual relays available for testing depend on the modules inserted into the control.



The following relays can be tested:

- | | | |
|--------------------------|-------------|--------------|
| • Burner | first stage | second stage |
| • Burner Modulation | open/close | |
| • Circuit 1 Heating Pump | on/off | |
| • Circuit 2 Heating Pump | on/off | |
| • Mixing Valve | open/close | |
| • DHW charging Pump | on/off | |
| • DHW Recirculation Pump | on/off | |

To perform the “REL AYS” test:

- Enter the key code.
- Turn the dial until the word “RELAYS” appears in the display.
- Press and hold the  button.
- Turn the dial until the display reads “BURNER ON”.
The Burner comes on.
- Release the  button.

If the burner is functioning properly, the burner symbol appears in the display.

- To access and display another relay, turn the dial without pressing the  button.
- To test this relay, press and hold the  button and turn the dial to activate the relay.

All relays can be tested sequentially and the switched status is displayed by an identifying symbol.

Return to main menu:

- Press the  button.

RETURN TO THE STANDARD DISPLAY

- Press the AUT button.

Note: The control resumes automatic operation if no entries are made for a period of 5 minutes.

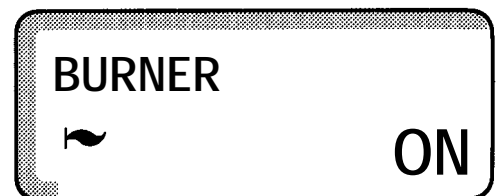
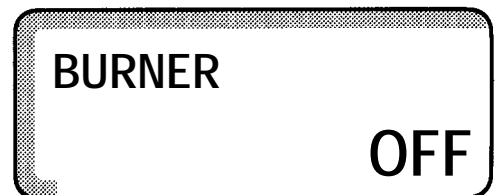
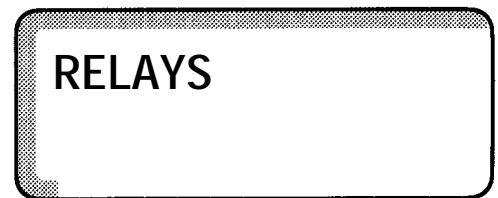

LCD Test:

One can verify with the LCD test if all digits and displays are functioning properly:

- Enter the key code.
- Turn the dial until the word “LCD TEST” appears in the display.
- Press and hold the  button.
- Turn the dial to ensure that all digits and symbols appear correctly in the display.

All digits and symbols must appear fully in the display.

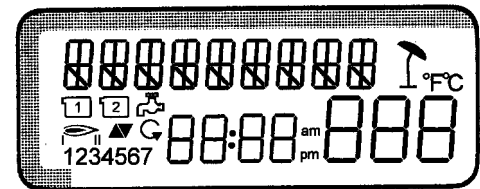
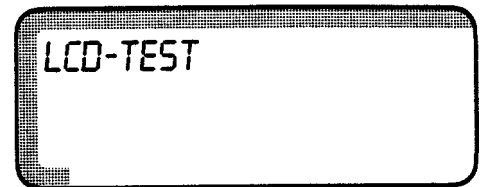

RETURN TO THE STANDARD DISPLAY

- Press the AUT button.



Note: The control resumes automatic operation if no entries are made for a period of 5 minutes.

10 Total System Reset

RESET

An overall system “RESET” returns all parameters back to the original factory settings.

To perform a total system “RESET”:

- Enter the key code.
- Turn the dial until the word “RESET” appears in the display.
- Press the  button and hold. Continue to hold the  button until all “8” characters disappear in the display.

NOTE: If the  button is released before all “8” characters have disappeared, no system reset has been performed.

- Release the  button. The “8” characters reappear to signify that the system reset is complete.

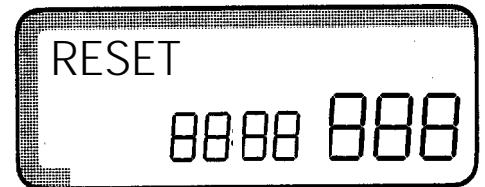
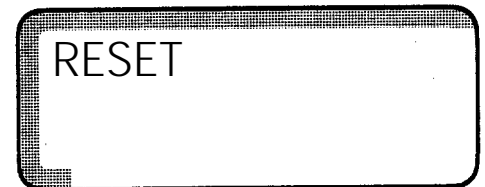
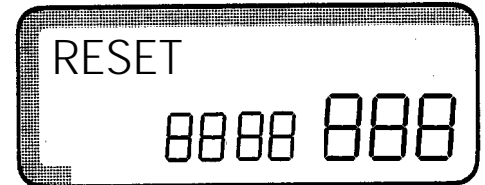

RETURN TO THE STANDARD DISPLAY

- Press the AUT button.

Note: The control resumes automatic operation if no entries are made for a period of 5 minutes.

Version Number

The version number is a manufacturer's identification number that provides product information regarding the control panel. It is recommended to write down this version number in case of future reclamation issues.

To access the Version Number:

- Enter the key code.
- Turn the dial until the word "Version" appears in the display
- Write down the specific version number.

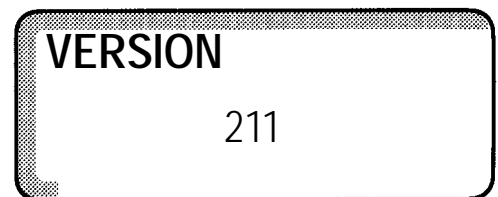

VERSION NUMBER : _____

RETURN TO THE STANDARD DISPLAY

- Press the AUT button.

Note: The control resumes automatic operation if no entries are made for a period of 5 minutes.

12 Trouble Shooting Procedures

The HS2105 has built-in self diagnostics software which continually monitors sensor inputs to ensure that measured values are within acceptable limits, monitors response of system components and signals descriptive error messages if these conditions are not met.

<u>Message (ERR)</u>	<u>Meaning</u>	<u>Action</u>
BURNER	Burner lock-out	Check burner and press burner reset.
BLR SENSR	Defective FK sensor	Check resistance of FK boiler sensor and verify with curve.
OA SENSOR	Defective outside air sensor	Check resistance of OA sensor and verify with curve.
DHW SENS	Defective DHW sensor	Check resistance of FB sensor and verify with curve.
MIX SENSR	Defective mixed circuit sensor (FV)	Check resistance of FV sensor and verify with curve. Check sensor placement and wiring.
REMOTE 1/2	Non-Responding Room Sensors	Check wiring to room sensor (wire 1 to 1, wire 2 to 2). If lights on room sensor blink, check HK dial internal on room sensor. Check if room sensor is activated on HS2105
HEATING	Heating system stays cold. Continued pump logic operation.	Turn control OFF/ON. Check boiler operation. Check manual high limit reset.
DHW	DHW stays cold for 2 hours.	Check tank pump operation and system piping.

These messages are very helpful in troubleshooting the HS2105. The control continues burner and circulator operation in case of sensor failure to prevent possible freeze-up of the heating system.

Record your specific settings at the installation level on this page for future reference. Observe that not all entries listed may actually be accessible as it depends on the modules inserted in the HS2105 and the value of certain parameters.

<u>Parameter</u>	<u>Range</u>	<u>Factory Setting</u>	<u>Actual Setting</u>
Language		Deutsch	
Reference Temperature PERIM-HTG	86°F - 194°F	167°F	
Reference Temperature FLOOR-HTG*	86°F - 140°F	113°F	
Freeze Protection	0°F - 50°F	34°F	
Room Sensor	OFF / ON	OFF	
Room Compensation	OFF / 1 - 18°F	5°F	
Night Setback Modes	Outside Setback	OASETBACK	
	Setback		
	Room Setback		
	Boiler Off		
Maximum Circuit 1 Temperature	158 - 210°F	176°F	
Maximum Circuit 2 Temperature*	68 - 140°F 68 - 194°F	122°F for FLOOR-HTG 194°F for PERIM-HTG	
Flue Gas Temperature**	OFF/120°F - 480°F	OFF	
Offset : Vertical Shift of Heating Curve	-9°F - 9°F	0°F	
Heating Circuit 1	NO SYSTEM/PERIM-HTG	PERIM-HTG	
Heating Circuit 2*	NO SYSTEM/PERIM-HTG FLOOR-HTG	FLOOR-HTG	
DHW Production	ON/OFF	ON	
DHW recirculation Pump	OFF/1/2/3/4/6/ON	2	
Burner System***	1 stage/2 stage /modulating	ONE-STAGE	
Modulation Range***	10% - 60%	30%	
Modulating Valve Operating Time***	5 sec. - 60 sec.	12 sec.	
Pumplogic (Condensate Protection)	59°F - 140°F	104°F	
Building Response	1/2/3	2	
DHW Prior	ON/OFF	ON	

*Requires Mixing Module FM 241

**Requires Communications Module KM 271

***Requires Burner Module FM 242

14 Sensor Curves (General)

Switch the power off before taking any measurements. Remove sensors from the back of the Ecomatic and measure the resistance of the cable ends. The curves show mean values and are subject to deviations.

Outdoor temperature sensor (FA)

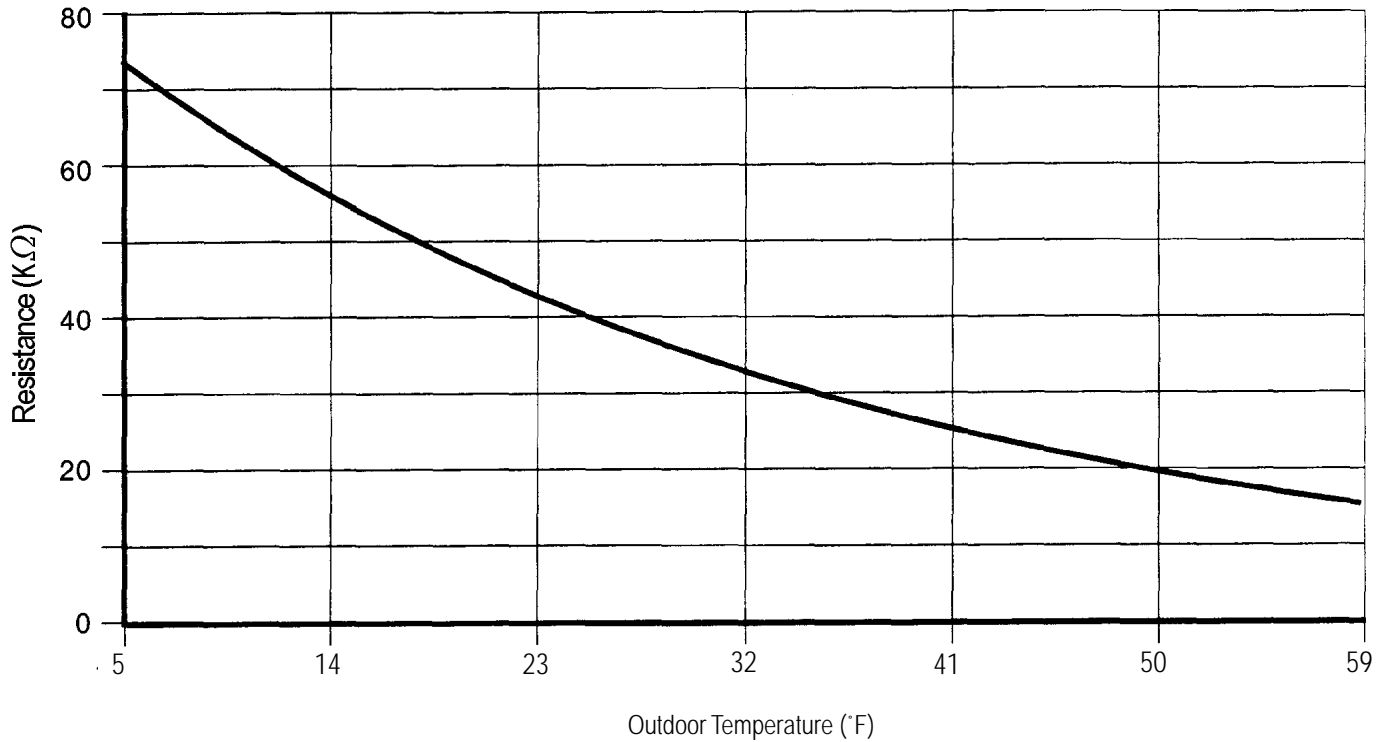

Boiler, domestic hot water and mixed circuit supply temperature sensors (FK, FB, FV)

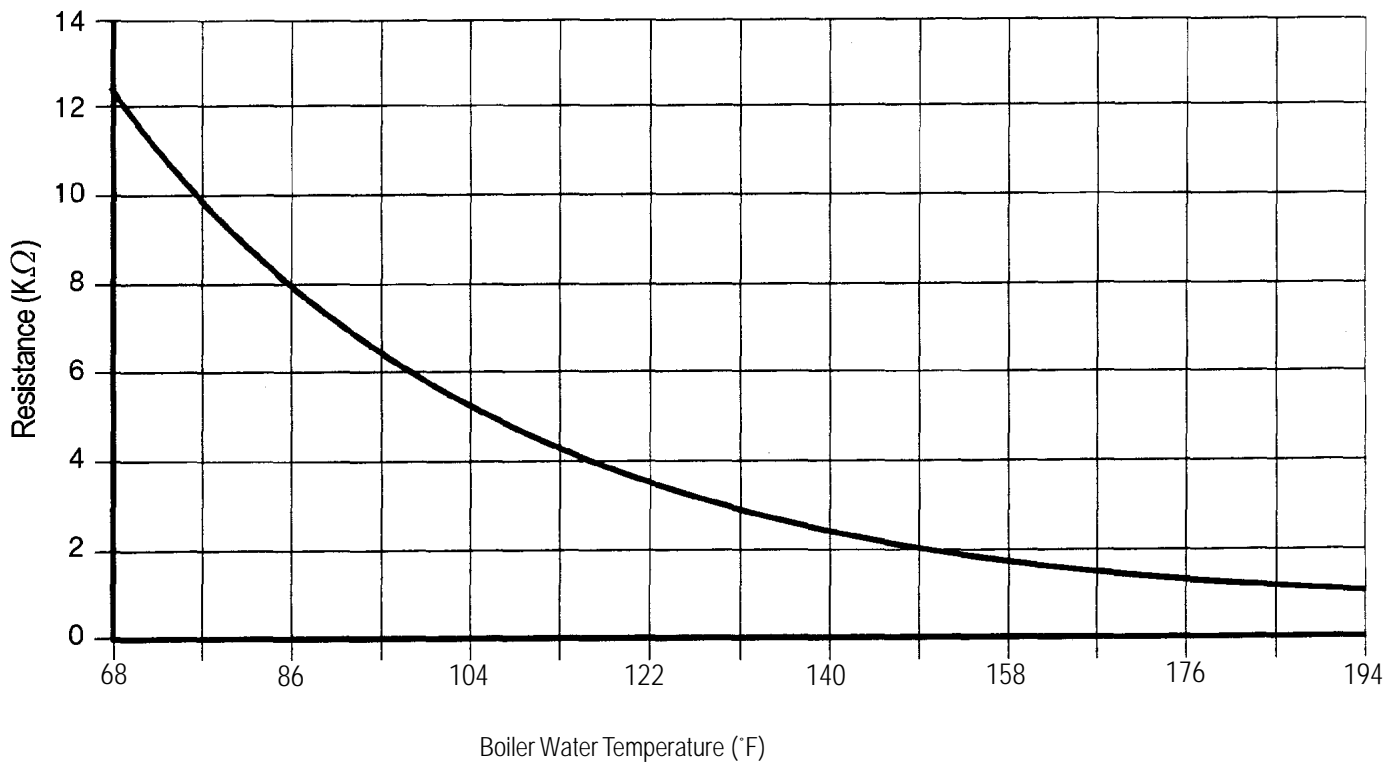

Room Temperature Sensor (BF)

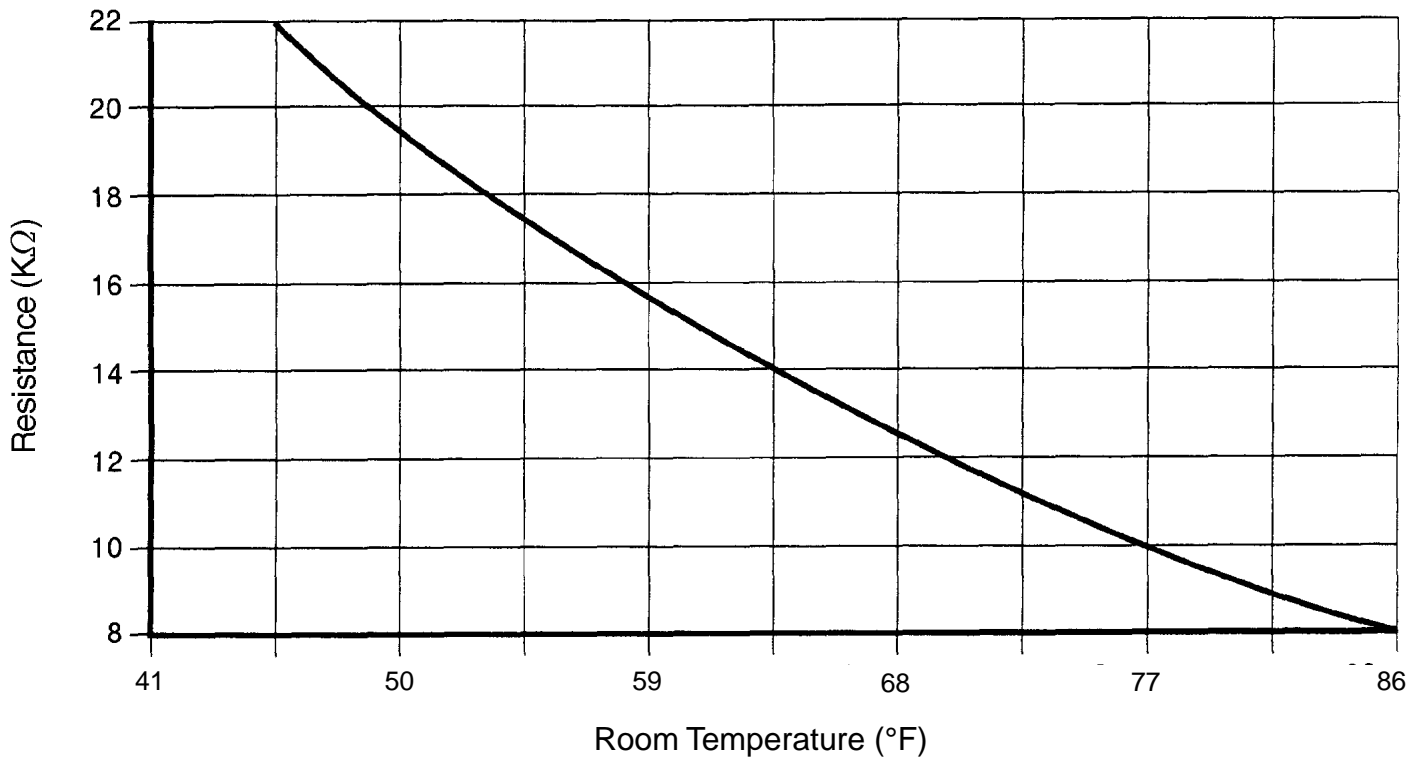

Note: The resistance of the room sensor can only be measured when an external sensor is connected to the EXT terminals in the room sensor. Measure at the EXT terminals with the room sensor disconnected from the HS2105 control.

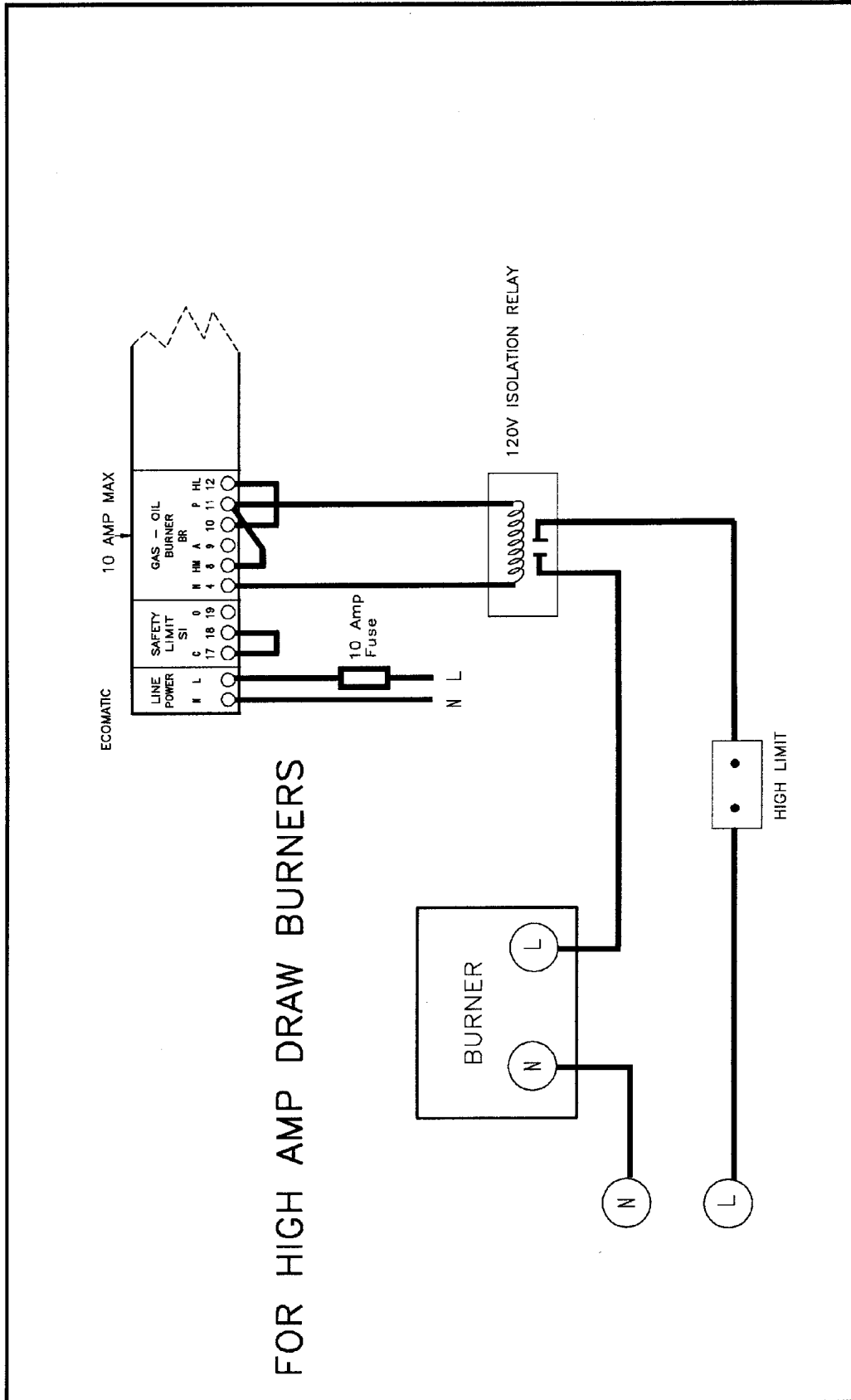

NOTES:

- (i) This wiring diagram is generic in scope and does not purport to address all design, installation or safety considerations. This diagram is for reference use by code officials, designers, and licensed installers. It is expected that installers have an adequate knowledge of accepted industry practices for the equipment, procedures, and applications involved.

BUDERUS HYDRONIC SYSTEMS		FILE NAME	ISORELAY	TYPE	GENERIC ECOMATIC WIRING
DATE	07/29/97	REV1	DRAWN BY	KM	APPROVED BY
			FOR		OIL BURNER WITH ISOLATION RELAY

15 Wiring Diagrams

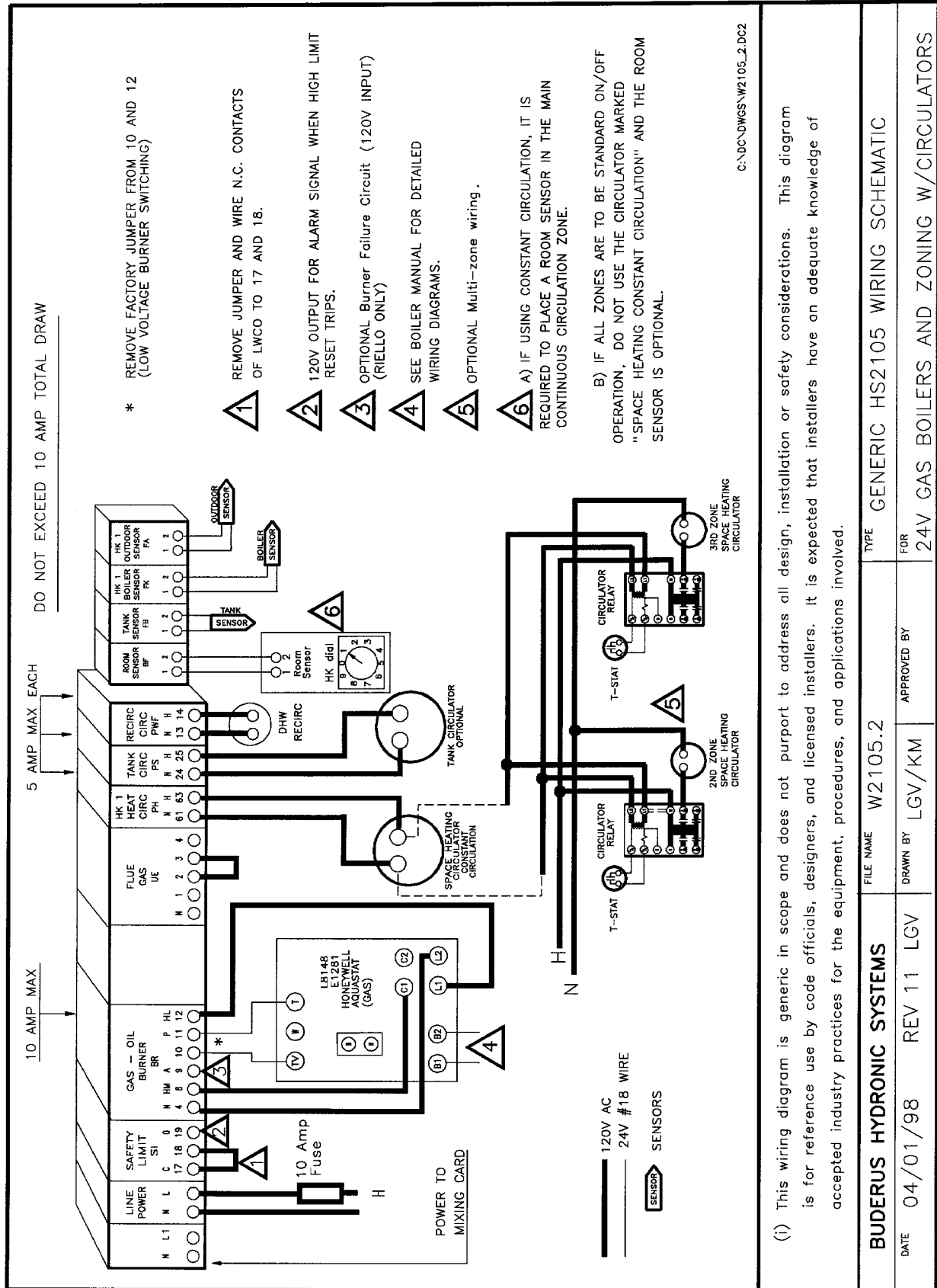

(i) This wiring diagram is generic in scope and does not purport to address all design, installation or safety considerations. This diagram is for reference use by code officials, designers, and licensed installers. It is expected that installers have an adequate knowledge of accepted industry practices for the equipment, procedures, and applications involved.

BUDERUS HYDRONIC SYSTEMS		FILE NAME	W2105.2
DATE	04/01/98	REV	11 LGV
		DRAWN BY	LGV/KM
		APPROVED BY	
		TYPE	GENERIC HS2105 WIRING SCHEMATIC
		FOR	24V GAS BOILERS AND ZONING W/CIRCULATORS

MODULE FM241

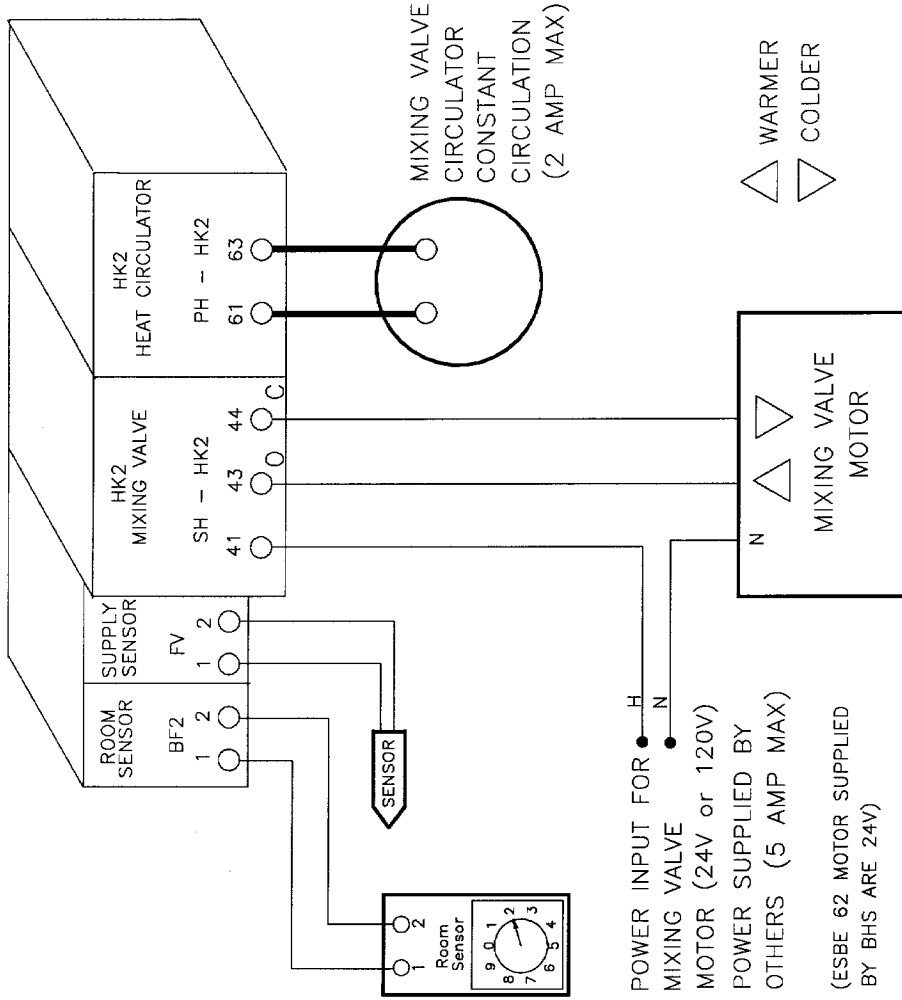

*DO NOT EXCEED 5 AMP TOTAL DRAW
 ——— 120V AC
 ——— 24V #18 WIRE

NOTE:
 REFER TO COMMENTS ON
 PREVIOUS DIAGRAMS REGARDING
 USE OF ROOM SENSOR AND
 MULTI-ZONE WIRING FOR
 MIXING VALVE CIRCUIT.

POWER INPUT FOR
 MIXING VALVE
 MOTOR (24V or 120V)
 POWER SUPPLIED BY
 OTHERS (5 AMP MAX)
 (ESBE 62 MOTOR SUPPLIED
 BY BHS ARE 24V)



(i) This wiring diagram is generic in scope and does not purport to address all design, installation or safety considerations. This diagram is for reference use by code officials, designers, and licensed installers. It is expected that installers have an adequate knowledge of accepted industry practices for the equipment, procedures, and applications involved.

C:\DC\DWGS\BHS0022.DC2

BUDERUS HYDRONIC SYSTEM		FILE NAME	BHS0022	TYPE	MODULE FM241
DATE	03/24/98	REV	3	FOR	MIXING VALVE & RADIANT PUMP WIRING
		DRAWN BY	LGV/KM	APPROVED BY	

15 Wiring Diagrams

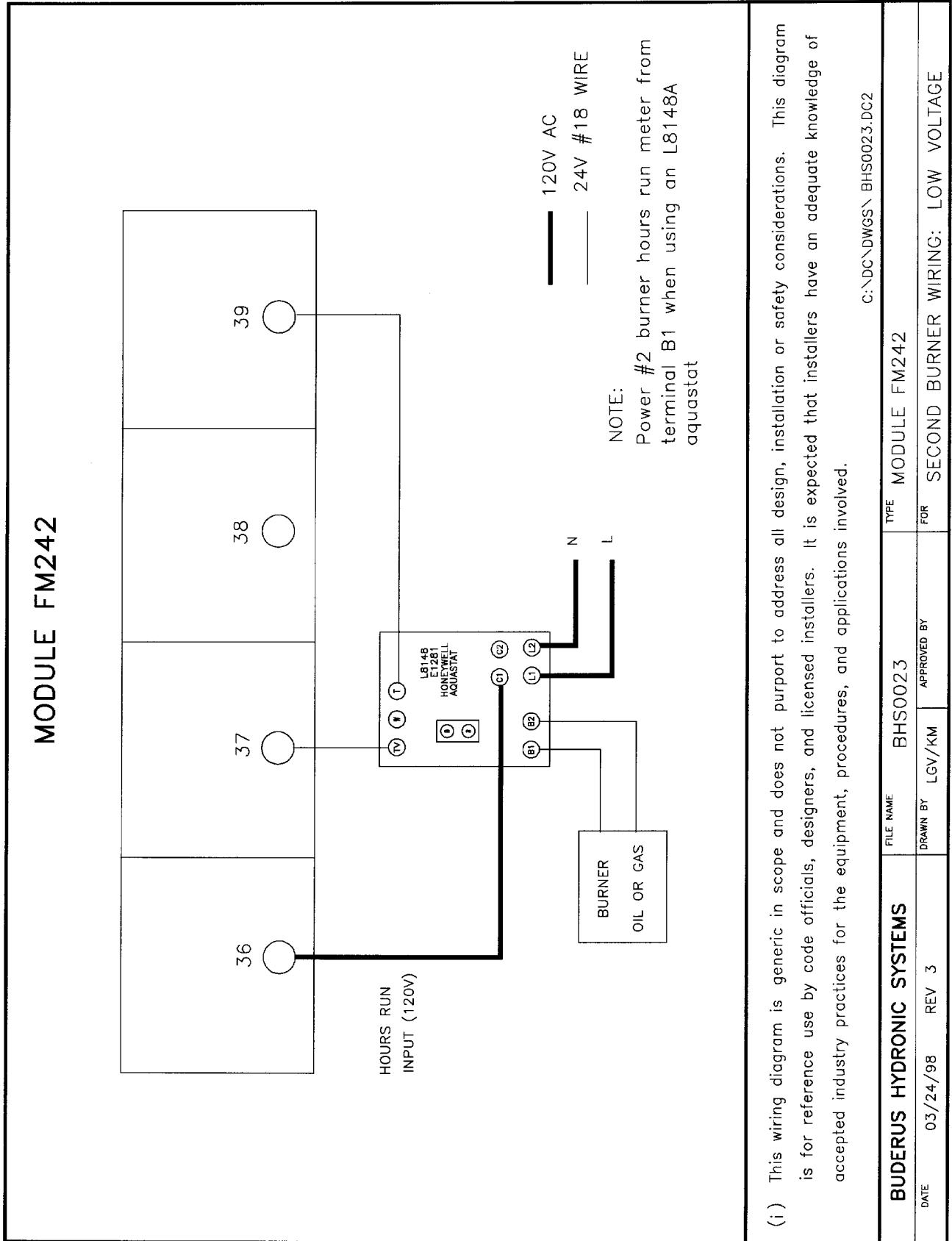

(i) This wiring diagram is generic in scope and does not purport to address all design, installation or safety considerations. This diagram is for reference use by code officials, designers, and licensed installers. It is expected that installers have an adequate knowledge of accepted industry practices for the equipment, procedures, and applications involved.

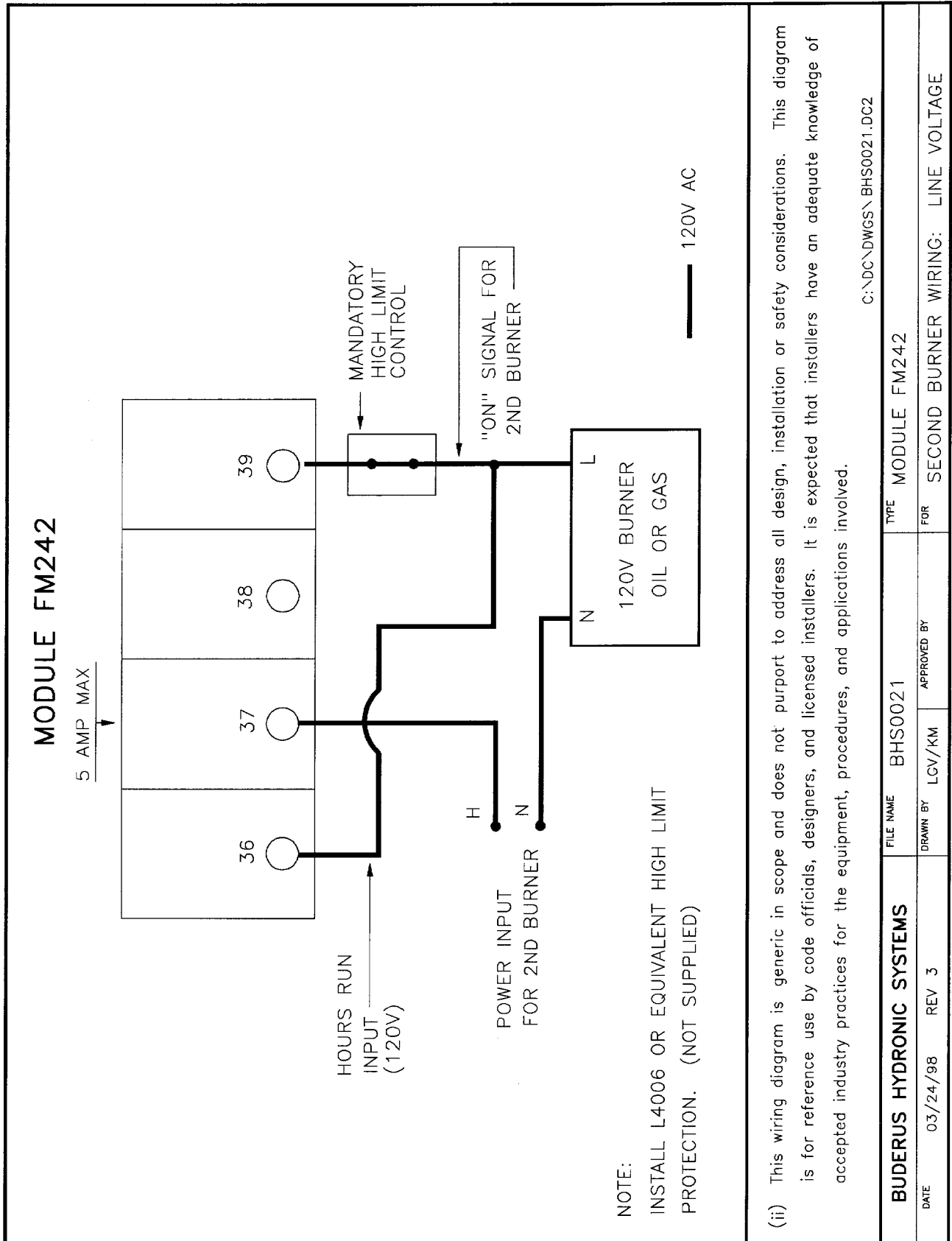

(ii) This wiring diagram is generic in scope and does not purport to address all design, installation or safety considerations. This diagram is for reference use by code officials, designers, and licensed installers. It is expected that installers have an adequate knowledge of accepted industry practices for the equipment, procedures, and applications involved.

BUDERUS HYDRONIC SYSTEMS		FILE NAME	BHS0021	TYPE	MODULE FM242
DATE	03/24/98	REV	3	FOR	SECOND BURNER WIRING: LINE VOLTAGE
		DRAWN BY	LCV/KM	APPROVED BY	

15 Wiring Diagrams

