

Assembly and Maintenance Instructions

Indirect Fired Hot Water Tank
Model S120 „US“



Buderus



NOTICE

Please observe and comply with all local and state requirements pertaining to the assembly and operation of an indirect fired domestic hot water tank!

**The Commonwealth of
Massachusetts requires that
the tank be installed by a
licensed plumber.**

Buderus Hydronic Systems reserve the right to make changes due to continued engineering improvement without notice.

Updating of Product Documentation

Feel free to contact us regarding suggestions for improvements of this product manual.

Address:

Buderus Hydronic Systems, Inc.
PO Box 647
Salem, NH 03079
[http\\www.buderus.net](http://www.buderus.net)

Document-number.: 6301 3628

Issue: 07/2001

Table of Contents

1	General Information4
1.1	Tank Packaging and Components4
1.2	Tank Placement.4
2	Transport5
3	Dimensions and Piping Connections6
4	Assembly and Installation.7
4.1	Safety Requirements7
4.2	Tank Piping Installation8
4.3	Temperature Control.9
4.3.1	Installation of Buderus Logamatic FB Sensor or Goldline SP30D Sensor Probe9
4.3.2	Installation of Honeywell Aquastat.9
5	Placing Tank in Operation.11
6	Maintenance12
6.1	Testing of the Magnesium Anode Rod.12
6.2	Tank Cleaning.13
6.3	Recommissioning after Tank Cleaning.13
7	Parts Break-down for S120 Tank.14

1 General Information

1.1 Tank Packaging and Components

The S120 indirect fired hot water tank is a 32 gal glass lined steel tank. The tank is fully packaged with a high density foam insulation and steel jacket panel. A Honeywell aquastat is standard supplied with the tank.

Additional components supplied with the tank are:

- 1 125 psi P and T valve
- 3 3/4" brass couplings
- 1 3/4" brass tee
- 1 Honeywell L4006 adjustable differential tank aquastat
- 1 Aquastat mounting bracket and 4 mounting screws
- 3 Adjustable tank leg leveling bolts
- 1 Roll of high quality teflon tape

1.2 Tank Placement

Install the tank in a dry, frost free room.

Make sure that the tank is completely drained before taking the tank out of use. Protect from freezing.

Place the tank on a level floor of sufficient strength.

Observe the recommended clearances as shown in Fig. 1. These dimensions are based on ample access for installation and maintenance (Fig. 1). Maintain a minimum clearance of 2" between hot water piping or tank surface to combustible surfaces.

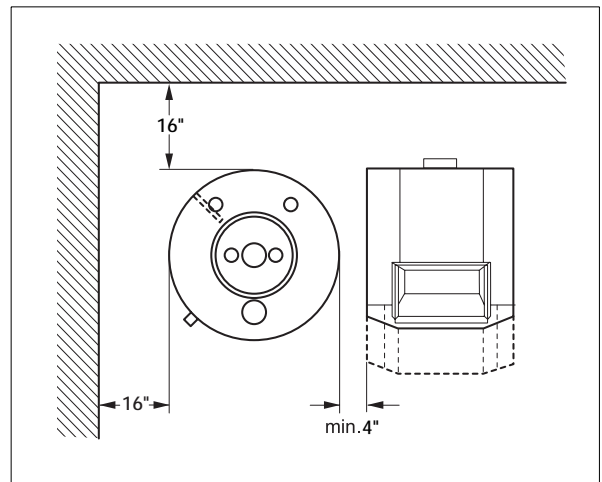

Fig. 1 Recommended clearance for installation and maintenance.

2 Transport

One can move the tank in its packaging as well as by itself using a Buderus Kuli cart. (Must be ordered separately). When using the Kuli cart, place tank on bottom support and secure tank to the handle bars with Kuli strap as shown in Fig. 2.

- Bring the tank to its destination.
- Remove plastic shrink wrap.

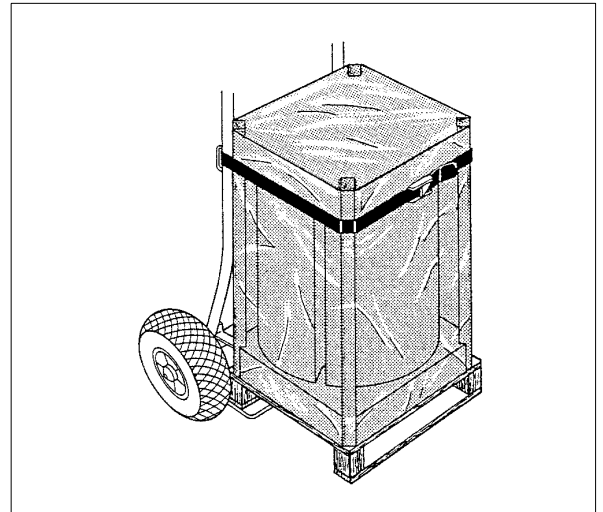

Fig. 2 Buderus-boiler-Kuli cart (sample picture)

- Remove top styrofoam piece and wooden corner posts. Place tank on its side on top of styrofoam piece.(Fig. 3, **Item. 1**).
- Remove bottom styrofoam piece from pallet.
- Scew 3 M10x30 bolts in bottom of tank to serve as tank leveling legs.(Fig. 3, **Item. 3**)

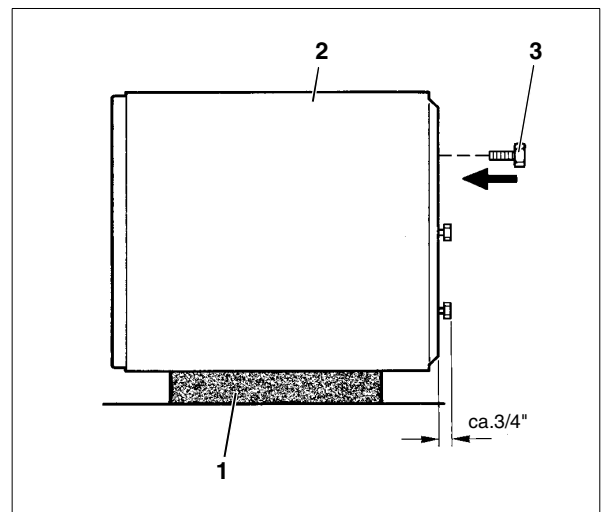

Fig. 3 Tank on top of styrofoam piece
(measurements in inches)

Item. 1: Styrofoam piece

Item. 2: Tank

Item. 3: Tank leveling bolts

3 Dimensions and Piping Connections

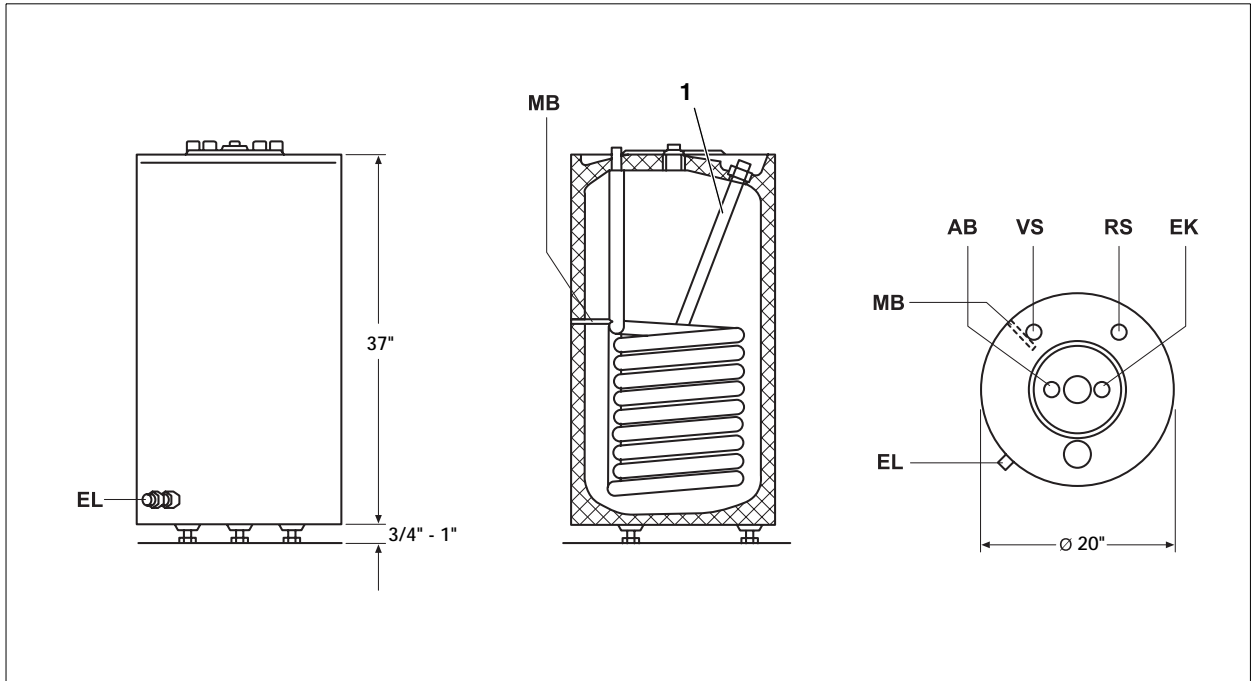

Fig. 4 Dimensions and piping connections (measurements in inches)

Item. 1: Magnesium Anode Rod

AB: DHW outlet (short dip tube)

EK: DHW inlet (long dip tube)

VS: boiler supply

RS: boiler return

MB: temperature measuring location (sensor or aquastat)

EL: tank drain

Model	VS	RS	EK/AB	Anode	Weight*
					Lbs
S120	3/4"	3/4"	3/4"	1"	158

Tab. 1 Dimensions and connections

*dry weight.

4 Assembly and Installation

- Level tank by adjusting the leveling bolts under the tank (Fig. 5).

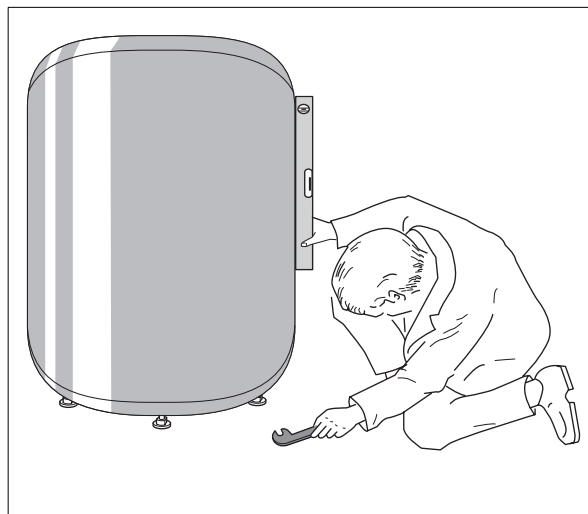

Fig. 5 Adjusting tank leveling bolts (sample picture)

4.1 Safety Requirements



TANK DAMAGE

When exceeding critical values.

ATTENTION!

- One must adhere to the following critical values for safe operation.

Critical Values

Temperature:

Heating water (boiler)	230 °F
Domestic water (tank)	203 °F

Operating pressure:

Heating water (boiler)*	87 psi
Domestic water (tank)	145 psi

* In the overall system, it is necessary to install a boiler pressure relief valve, expansion tank and P and T valve for the tank.

4.2 Tank Piping Installation

1. Install all piping and components per local and state codes (Fig. 6).
- Use threaded connections on all tank fittings. Fittings are supplied. It is suggested to install shut off valves in all water lines.
 - Install the 3/4" brass tee fitting on the DHW outlet connection (AB) with the teflon tape provided. Install P and T valve (Fig. 6, **Item. 2**) into top of the brass tee. Pipe the relief line full port to a nearby floor drain.
 - Add label to P and T relief valve stating: „Relief valve may release water during heating of the tank“.
 - Install furnished 3/4" brass couplings with teflon tape provided on other three tappings located on top of the tank. (See Fig. 4 for details)
 - Periodically test the operation of the P and T valve by manually opening the valve.
 - All piping must be installed without undue stress!
 - Test all piping connections for leaks.

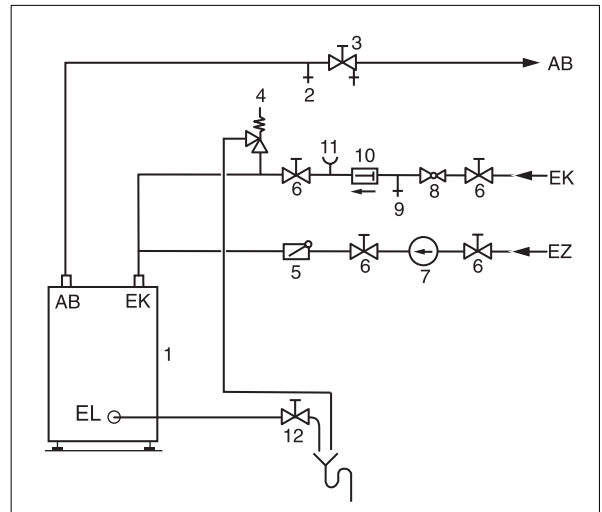

Fig. 6 Tank piping installation (sample picture)

Item. 1: Tank

Item. 2: P and T valve

Item. 3: Shut off valve with drain

Item. 4: Purge valve / vacuum breaker

Item. 5: Flow valve

Item. 6: Isolation valve

Item. 7: DHW recirculation pump (optional)

Item. 8: Pressure reducing valve (as required)

Item. 9: Test port (as required per local code)

Item. 10: Back flow preventer (as required per local code)

Item. 11: Pressure test port (as required)

Item. 12: Tank drain

AB: DHW outlet

EK: Cold feed

EZ: DHW recirc inlet

EL: Tank drain connection

Safety Valve Requirements *

Minimum Connection Size	Net Water Volume	Max. Heating Capacity
	Liters/gals	Btu/hr
DN 15 (=1/2")	200/53	255,000

*based on DIN norm 4753.

4.3 Temperature Control

For accurate control of the tank water temperature, one has the option of using either the sensor supplied with the Buderus Logamatic control or SP30D control, or the Honeywell aquastat supplied with the S120 tank.

4.3.1 Installation of Buderus Logamatic FB Sensor or Goldline SP30D Sensor Probe

- Fully insert the suitable DHW sensor (Fig. 7, **Item. 2**) together with the tension spacer (Fig. 7, **Item. 1**) supplied with the tank into the factory installed tank well (Fig. 7, **Item. 3**). Wire sensor leads to suitable control terminals. (Sensor leads can be extended using regular thermostat wiring.)



NOTICE

Ensure that the entire surface of the sensor is in contact with the tank well.

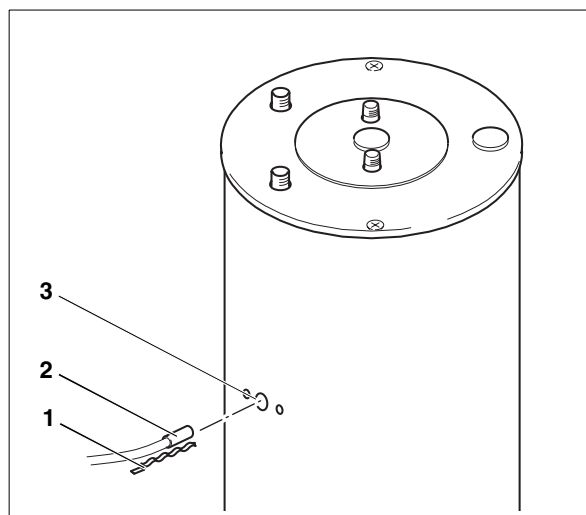

Fig. 7 Installation of temperature sensor

Item. 1: Tension spacer

Item. 2: DHW tank sensor (FB sensor from Logamatic or SP30D probe)

Item. 3: Tank dry well

4.3.2 Installation of Honeywell Aquastat

- Remove cover from aquastat by removing hex head screw on top.
- Secure mounting bracket (Fig. 8, **Item. 3**) furnished with tank to base of aquastat (Fig. 8, **Item. 2**) using the 2 screws (Fig. 8, **Item. 1**). (One may need to remove prior mounting bracket).

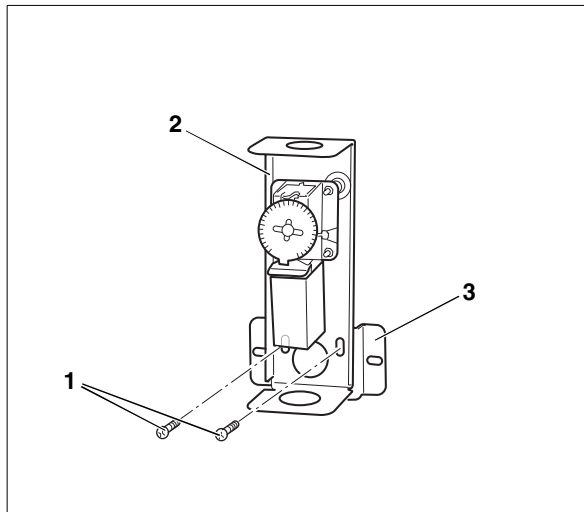

Fig. 8 Attaching bracket to aquastat

Item. 1: Screws C-ST 4,2 × 13 mm

Item. 2: Aquastat

Item. 3: Bracket

- Insert aquastat capillary with tension spacer (Fig. 9, **Item. 4 and 5**) into tank dry well (Fig. 9, **Item. 3**).
- Secure aquastat assembly (Fig. 9, **Item. 2**) with 2 screws (Fig. 9, **Item. 1**) to the tank jacket.



NOTICE

Wire the aquastat into suitable control and set desired DHW tank temperature at aquastat.



DANGER

due to electricity.

DANGER!

- Shut down main switch before working on the boiler/tank system.

- Put aquastat cover back in place.

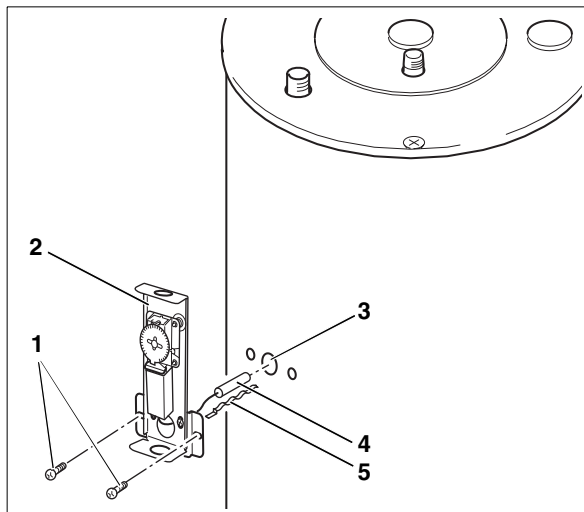

Fig. 9 Installation of Honeywell aquastat

Item. 1: Sheet metal screws C-ST 4,2 × 13 mm

Item. 2: Aquastat

Item. 3: Tank dry well

Item. 4: Aquastat capillary

Item. 5: Tension spacer

5 Placing Tank in Operation

- Prior to start-up, verify that the tank is filled with water and that the cold feed is functional and unrestricted.
- Check all connections for leaks.
- Information regarding boiler/burner operation start-up can be found in their respective manuals
- The complete system must be placed in operation by the installing contractor or one of his associates in the presence of the end user. The end user shall be informed about start-up procedure and system operation.

6 Maintenance

Unless specified in writing to the contrary, the S120 tank should only be used for heating of domestic hot water.

A bi-annual inspection of the tank is recommended and to be performed by a service technician. This inspection involves assessing the status of the magnesium anode rod and the need for cleaning of the tank interior.

In case of unfavorable water conditions (hard water) or when operating the tank at high tank temperatures (greater than 140 °F), an annual inspection is recommended.

6.1 Testing of the Magnesium Anode Rod



DANGER

due to electricity.

DANGER!

- Prior to inspection, disconnect electricity.

- Close off cold feed (EK), and drain tank. Open a faucet at a higher location to vent the tank.
- Remove plastic plugs (Fig. 10, **Item. 1**) from the magnesium anode rod and clean-out opening.
- Unscrew the magnesium anode rod (Fig. 10, **Item. 2**) from the tank using a pipe wrench.



NOTICE

Keep surface of magnesium anode rod free from oil or grease.

Clean surface of anode rod with water.

- Check surface degradation of anode rod.
- Change out the anode rod if its diameter is less than 1/2" to 3/4" or if its surface is severely pitted. No corrosion protection of tank when anode rod is severely degraded. Tank warranty is voided in this case.

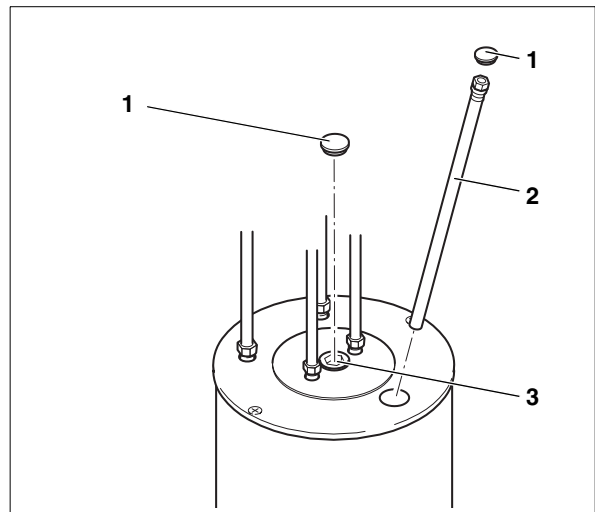

Fig. 10 Removal of magnesium anode rod

Item. 1: Plastic plugs

Item. 2: Magnesium anode rod

Item. 3: Tank inspection opening

6.2 Tank Cleaning

- Remove tank inspection plug (Fig. 11, **Item. 1**) using a 15/16" Allen wrench.
- Visually inspect tank interior and clean when necessary. To remove scale and build-up from tank coil, turn on boiler and tank circulator and circulate hot boiler water through tank coil. Spray cold water on coil surface to shock build-up from tank coil. Rinse scale and debris from tank through tank drain.



TANK DAMAGE

due to contact with sharp objects.

ATTENTION!

- **Never** attempt to remove coil build-up with a sharp object, as it may damage the tank's protective surface coating.

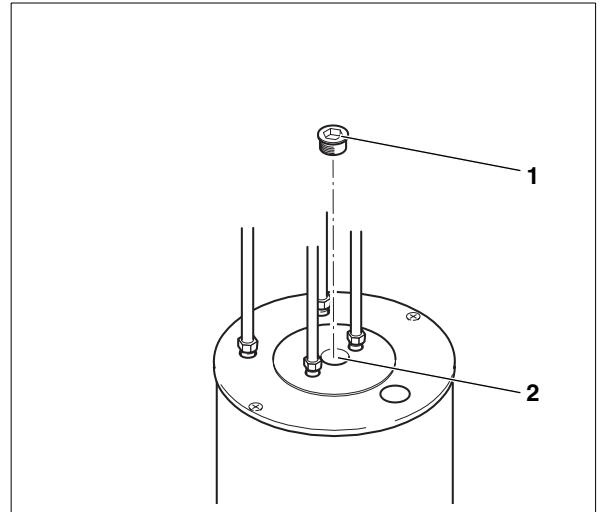

Fig. 11 Removal of inspection plug

Item. 1: Inspection plug (1")

Item. 2: Inspection and clean-out opening

6.3 Recommissioning after Tank Cleaning

- Install magnesium anode rod (Fig. 10, **Item. 2**). Use quality teflon tape for sealing. Wrap generously.
- Install inspection plug (Fig. 11, **Item. 1**). Use quality teflon tape for sealing. Wrap generously.
- Place system back in operation.
- Check all connections for leaks.
- Put plastic plugs (Fig. 10, **Item. 1**) back in place on magnesium anode and inspection plug.

7 Parts Break-down for S120 Tank

Item.-Nr. in Fig. 12 Page 15	Part Description	Part-Nr.	Quantity
5	Indirect fired hot water tank S120 „US“ complete.	6320 5018	1
Available individual parts:			
10	Magnesium anode rod D26 x 505 mm, G1“	3868 538	1
20	Inspection plug	6790 1380	1
30	Aquastat mounting bracket	6301 3510	1
40	Tank top cover, blue	6301 3260	1
50	Tank top screws, DIN 7981-C-ST6,3 x 19 - A3T	x	2
60	Tension spacer	7099 268	1
70	Fill and drain valve (German model)	479 762	1
80	Plastic plugs, blue	6301 3463	2
90	Hexhead bolts, ISO 4017- M10 x 30 - 8.8 - A3K	x	3
100	DHW outlet dip tube, 3“ long	5222 171	1
110	DHW inlet dip tube, 32“ long	5222 173	1

Tab. 2 Spare Parts for S120

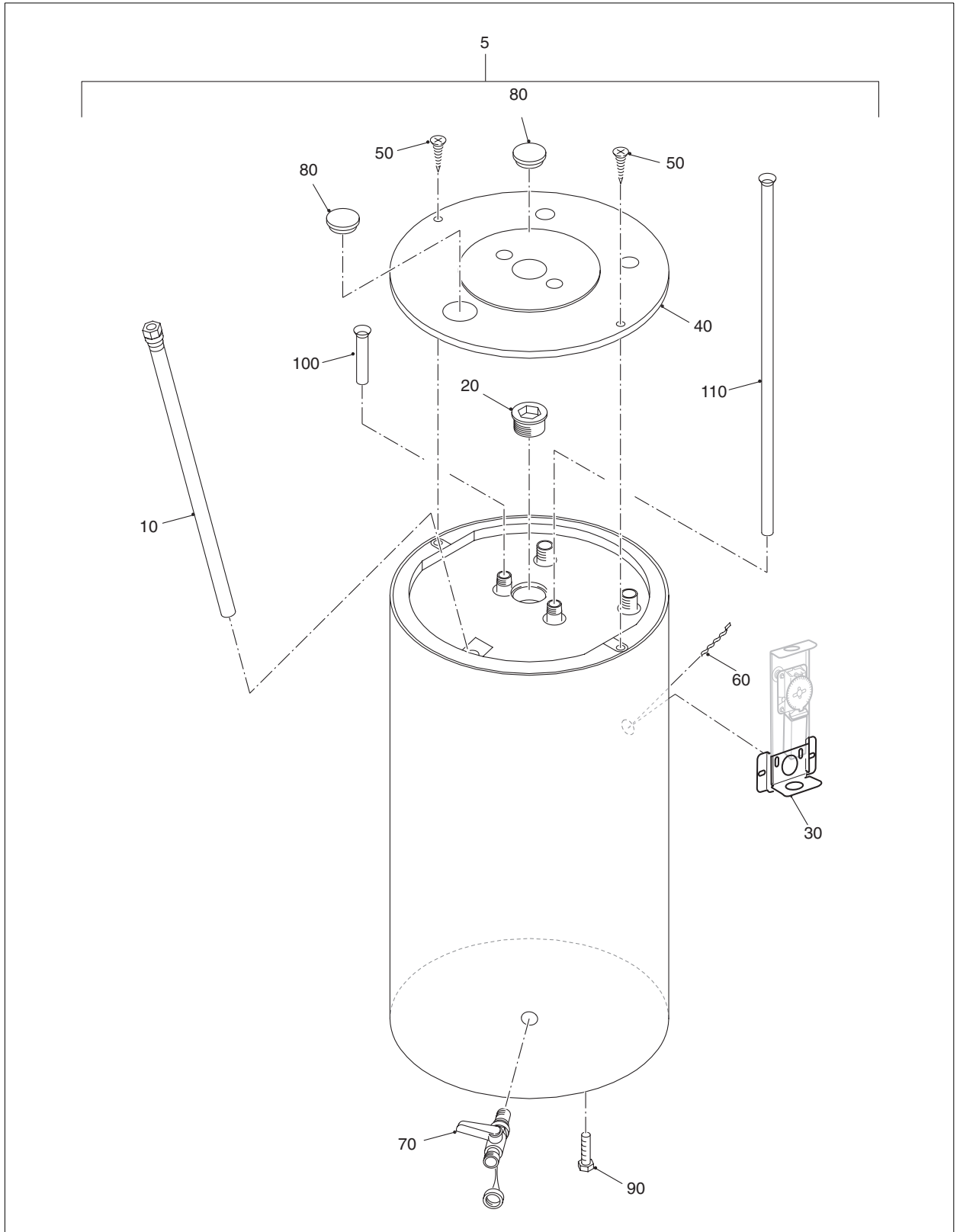

Fig. 12 Spare Parts for S120

Boiler installed by:
(contractor's address)

Boiler installed on:
(date of installation)

Buderus
HYDRONIC SYSTEMS

Buderus Hydronic Systems
50 Wentworth Avenue
Londonderry, NH 03053 USA
Tel: (603) 552-1100 • Fax: (603) 421-2719
www.buderus.net

Buderus Hydronic Systems, Inc. reserves the right to make changes without notice due to continuing engineering and technological advances.