

GA-K - Chimney Flue Gas System for GB125 Oil Condensing Boiler

For trained and certified
installers

Please read carefully prior
to installation.

Contents

1	General information	3
1.1	Standards, regulations and directives	3
1.2	System certification	3
2	Safety	4
2.1	About these instructions	4
2.2	Intended use	4
2.3	Layout of the instructions	4
2.4	Please follow these instructions	4
2.5	Tools, materials and accessories	4
2.6	Disposal	4
3	Product description, scope of delivery and technical data	5
3.1	Basic kit GA-K (DN125/80)	5
3.2	Technical data	6
4	Notes on installation and operation	7
4.1	Installation requirements for the boiler room	7
4.2	Condensate drain	7
4.3	Installation in an existing chimney shaft	7
4.4	Safety distances to combustible material	7
4.5	Instructions for inspection and clean-out sections	8
5	Installing the flue gas system	9
5.1	General installation notes	9
5.2	Installing the basic kit GA-K	10
5.3	Installing the flue pipe	11
5.4	Establishing chimney connection	13
5.5	Appliance connection	13
6	Inspecting the flue gas system	14

1 General information

1.1 Standards, regulations and directives

It is the responsibility of the installer to ensure that the system corresponds to all current regulations and rules.

This flue gas system is only approved for the GB125. Use with other boilers is not permitted.

Only use parts of this flue gas system and do not combine it with other systems.

1.2 System certification

For Logano plus GB125 oil condensing boilers:

The GB125 is system-certified with this flue gas system for the USA and Canada.

An individual approval of the flue gas system is not required.

The flue gas system must be installed in accordance with these installation instructions. The maximum permissible overall length and the number of changes of direction are specified in the "Technical data" section.

2 Safety

2.1 About these instructions

These installation instructions contain important information for the safe and appropriate installation and start-up of the flue gas systems.

These installation instructions are designed for specialists, who – through their vocational training and experience – are knowledgeable in the handling of heating systems and oil installations.

2.2 Intended use

The basic kits GA-K may be used as flue gas systems for the Buderus oil condensing boilers with maximum flue gas temperatures of 248 °F (120 °C). Suitable are, e.g. boilers of the types:

- Logano plus GB125-22/30/35

2.3 Layout of the instructions

Two levels of danger are identified and signified by the following terms:



RISK OF FATAL INJURY

Identifies possible dangers emanating from a product, which might cause serious injury or death if appropriate care is not taken.



RISK OF INJURY/SYSTEM DAMAGE

Indicates a potentially dangerous situation that could cause minor or moderately serious injuries or to damage to property.

Additional symbols for identification of dangers and user instructions:



USER NOTE

User tips for optimal use of equipment and adjustment as well as other useful information.

2.4 Please follow these instructions



Risk of fatal injury

FROM FLUE GAS POISONING.

Insufficient ventilation or leaky flue gas lines may cause dangerous flue gas leaks.

- Make sure that air intake or exhaust air vents are not closed off or their size reduced.
- The boiler must not be operated until the obstruction has been removed.
- Inform the system user in writing of the fault and its associated dangers.



Risk of fatal injury

DUE TO FALLS AND FALLING PARTS.

- Take appropriate action to prevent accidents during all work on roofs.
- Take all necessary precautions against a possible fall while working on the roof.



Only use original Buderus spare parts. Damage caused by the use of parts not supplied by Buderus is excluded from the Buderus warranty.

2.5 Tools, materials and accessories

For the installation of the boiler, you will require the standard tools used for central heating and oil and water systems.

The following may also be necessary:

- Safety equipment for work on the roof
- Mounting cable at least 3 m longer than the chimney

2.6 Disposal

- Dispose of the packaging of the flue gas system in an environmentally responsible manner.
- Dispose of components of the flue gas system that are replaced through an authorized agent in an environmentally responsible manner.

3 Product description, scope of delivery and technical data

3.1 Basic kit GA-K (DN125/80)

The air flue gas line is a concentric pipe-in-pipe system of plastic or steel. The outer concentric pipe is a combustion air pipe, the inner pipe is a flue gas pipe.

Only one boiler may be connected to the flue pipe. In the vertical part of the flue gas line, plastic pipes or flexible plastic corrugate pipe ÜB-Flex can be used.

- Before starting any installation work, check that all listed items are present.

Contents (Fig. 2)

1	Concentric inspection T-joint	1 ×
2	Concentric pipe, DN125/80, 39" (1000 mm)	1 ×
3	Cover plate, DN125, white	1 ×
4	Concentric wall penetration, DN125/80, white	1 ×
5	Load bearing elbow, 87°, DN80, with bracing and support rail	1 ×
6	Chimney spacer (2 piece)	6 ×
7	Termination, DN80, L = 20" (500 mm)	1 ×
8	Concentric flue gas connector	1 ×
9	Concentric boiler adapter	1 ×
	CENTROCERIN® anti-seizing compound (not shown)	1 ×

Purchase additional extension pieces to complete the installation.

For chimneys with an offset a flexible liner for parts or the complete length of the chimney is available as an accessory. (ÜB-Flex, Part-# 8709 4036)

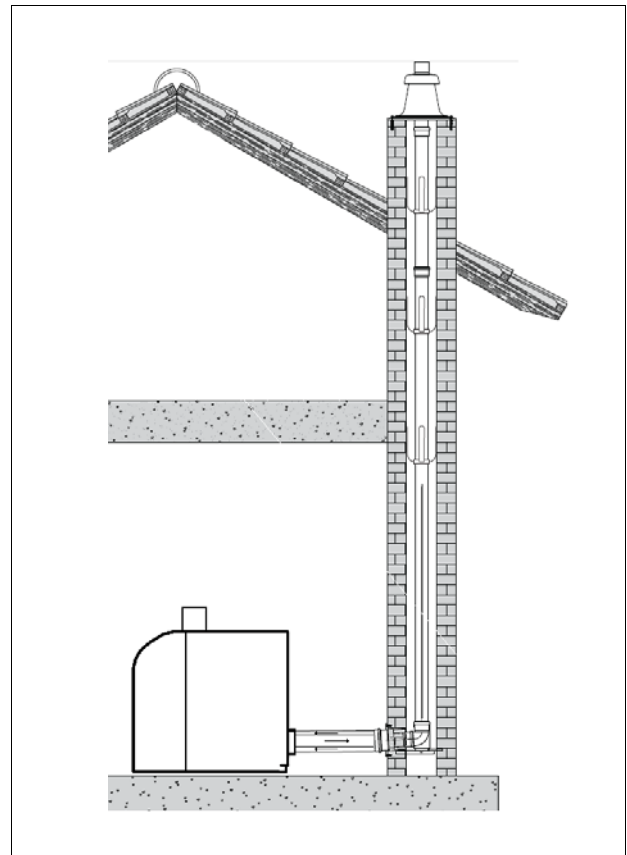

Fig. 1 Basic kit GA-K

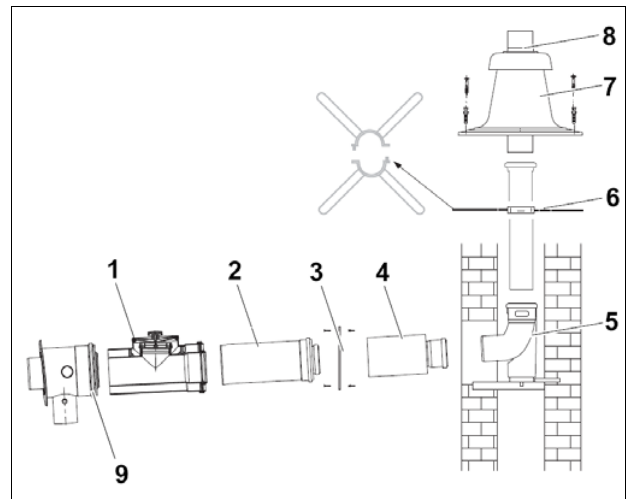

Fig. 2 Scope of delivery basic kit GA-K

3.2 Technical data

Flue system	Logano plus			Minimum chimney flue size suitable as chase for pipe
	GB125			
	22	30	35	
GA-K	51 ft. (17 m)	64 ft. (21 m)	71 ft. (23 m)	DIA 5-1/2" (Ø 130 mm); 5" x 5" (120 mm x 120 mm)

Tab. 1 Maximum overall lengths and minimum chimney flue diameters

Pipe changes of direction

The overall lengths apply for systems with one elbow. Every additional elbow (accessory) reduces the maximum vent length by 3 ft (1 m).

4 Notes on installation and operation

4.1 Installation requirements for the boiler room

4.1.1 Balanced flue operation (GA-K)

The GB125 is designed for balanced flue operation only. All combustion air is taken in from outside.

4.2 Condensate drain

The flue gas line has an integrated condensate drain in the boiler connector. The condensate from the flue gas line flows directly into the boiler's trap (siphon).

Follow local rules when draining condensate into municipal sewage systems.

It is not recommended to drain untreated condensate in septic systems.

In any case follow local codes and regulations.

Consult the boiler installation instructions for details on installing a condensate neutralizer.

4.3 Installation in an existing chimney shaft

The chimney must be cleaned by the chimney sweep before installing the flue gas system if

- the combustion air is taken in via an existing chimney shaft
- oil fireplaces or fireplaces for solid fuels were connected or if
- a dust accumulation due to brittle chimney gaps is anticipated.

If during operation, an ongoing dust accumulation is anticipated or if there are remainders of oil or solid fuel fireplaces, the basic kits GAL-K or DO-S can be used instead of the basic kit GA-K.

4.4 Safety distances to combustible material

The design of the concentric venting system allows installation with zero (0", 0 mm) clearance.

Therefore, no particular protective measures or safety distances are required for combustible material or furniture.

4.5 Instructions for inspection and clean-out sections

4.5.1 Inspection and clean-out sections

Local codes and regulations may require an inspection and clean-out section to be installed close to the boiler.

Inspection and clean-out sections allow inspecting and cleaning the venting system without dismantling sections of it.

4.5.2 Arrangement of the lower inspection and clean-out section

The lower inspection and clean-out section must be installed sideways in the horizontal section of the flue gas pipe as the first section after the boiler adapter (Fig. 3, Item 1).

- Keep area of at least 3 ft. x 3 ft. (1 m x 1 m) clearance in front of the inspection section for easy access.

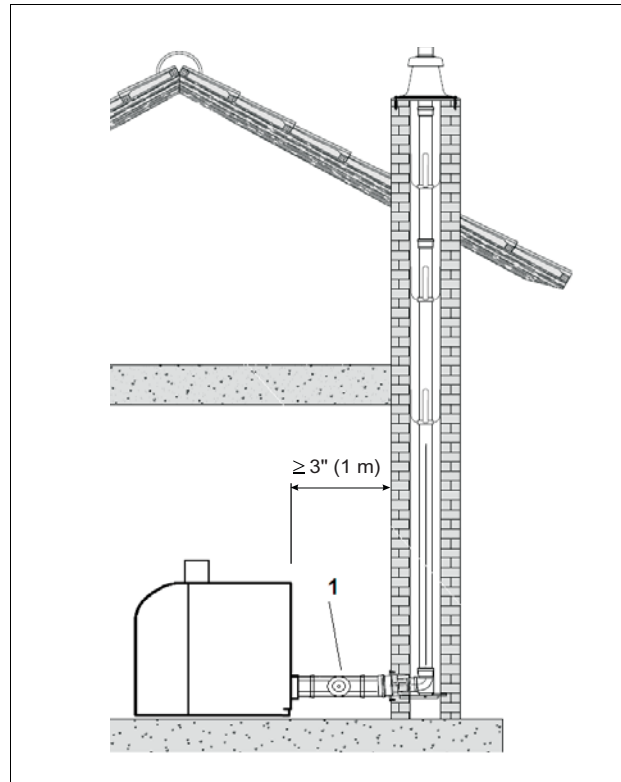

Fig. 3 Lower inspection and clean-out sections

4.5.3 Upper inspection and clean-out sections

An upper inspection is needed if there are any changes in direction of the vertical flue gas pipe, e.g. when elbows are used to create an offset. Install the inspection and clean-out section above the change in direction.

- Keep an area of at least 1-1/2 ft. x 1-1/2 ft. (0.5 m x 0.5 m) clearance in front of the inspection section for easy access.

5 Installing the flue gas system

5.1 General installation notes

Trimming pipes



RISK OF INJURY

from sharp edges.

- Wear work gloves.

- With concentric pipes, pull the inner pipe out of the outer pipe.
- Trim pipes at a right angle to the required length x (Fig. 4).
With concentric pipes, trim flue gas and air intake pipe to the same length.
- Carefully remove the burrs from cut edges.
- Put the flue gas and air intake pipes together again.

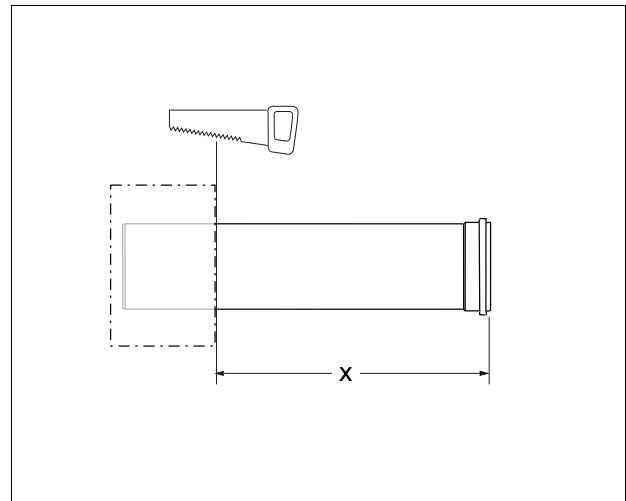

Fig. 4 Trimming pipes

Installing the pipe connection

Assemble the pipes so that the sleeve points in the direction of the flue gas stream. Only use original Buderus flue gas pipe gaskets!

- Coat the gaskets (Fig. 5, **Item 1**) with CENTROCERIN[®] anti-seizing compound.
- Push the flue gas pipes into one another (Fig. 5, **Item 2**) with a slight turning motion until the stop.
With concentric pipes, push the air intake pipe (outer pipe, Fig. 5, **Item 3**) again.
Make sure that the gaskets do not shift.

Loosening the pipe connection

- Pull the pipes out of one another while turning slightly.

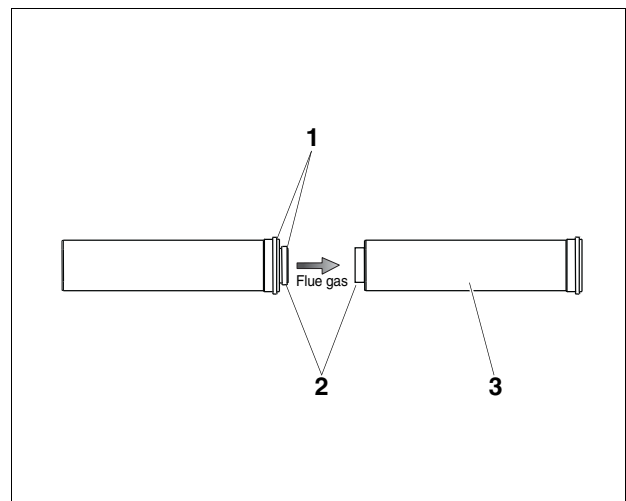

Fig. 5 Installing the pipe connections

- 1 Gaskets
- 2 Flue gas pipes (inner pipes)
- 3 Air intake pipe (outer pipe)

5.2 Installing the basic kit GA-K

5.2.1 Determining position of the chimney penetration

Cut a penetration into the chimney allowing the vent pipe to run at a 3° slope.

The size the opening must be sufficient to install the support rail as shown in 5.2.2.

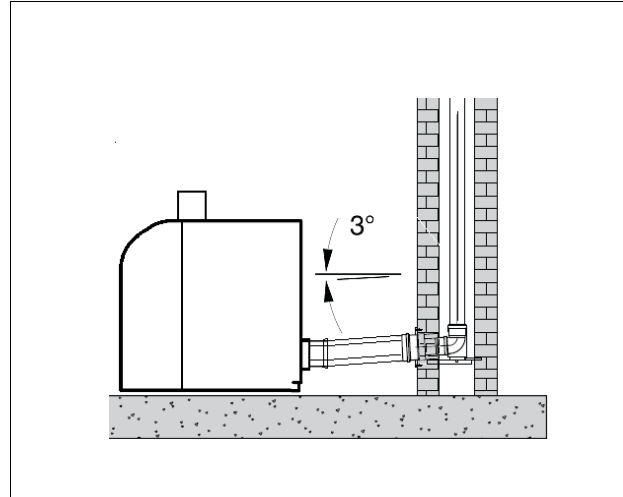

Fig. 6 Determining position of the chimney penetration

5.2.2 Installing the support rail

- Drill a $3/8$ " (10 mm) hole in the rear wall of the chimney, $1-3/8$ " (35 mm) above the bottom of the chimney penetration (Fig. 7).
- Shorten support rail (Fig. 7, **Item 1**) if necessary and carefully insert the rod into the hole.
- Lay the near end of the rail onto the bottom of the penetration. It will later be mortared in place together with the pipe connecting from the boiler.

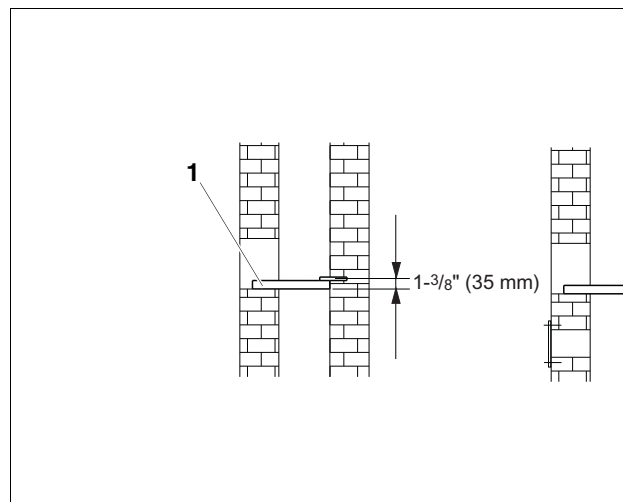

Fig. 7 Installing the support rail (dimensions in mm)

1 Support rail

5.3 Installing the flue pipe



RISK OF FATAL INJURY

due to falls or falling parts.

- Take appropriate action to prevent accidents during all work on roofs.
- Take all necessary precautions against a possible fall while working on the roof.

5.3.1 Materials and tools needed

- Flue gas pipe in appropriate length, with gaskets
- Chimney spacer (consists of 2 pieces each)
- Load bearing elbow
- Termination
- Chimney cover
- CENTROCERIN® anti-seizing compound
- Mounting cable at least 9 ft. (3 m) longer than the chimney
- Hammer drill with masonry drill bit 1/4" (6 mm)
- 4 wall anchors 1/4" (6 mm) and wood screws
- Screwdriver, nut driver
- Tape measure

5.3.2 Measure out pipe lengths

- Place load bearing elbow (Fig. 8, **Item 1**) in the middle on the support rail in the chimney.
- Determine pipe length L between sleeve of the load bearing elbow and termination (Fig. 8, **Item 2**) with the help of the mounting cable.

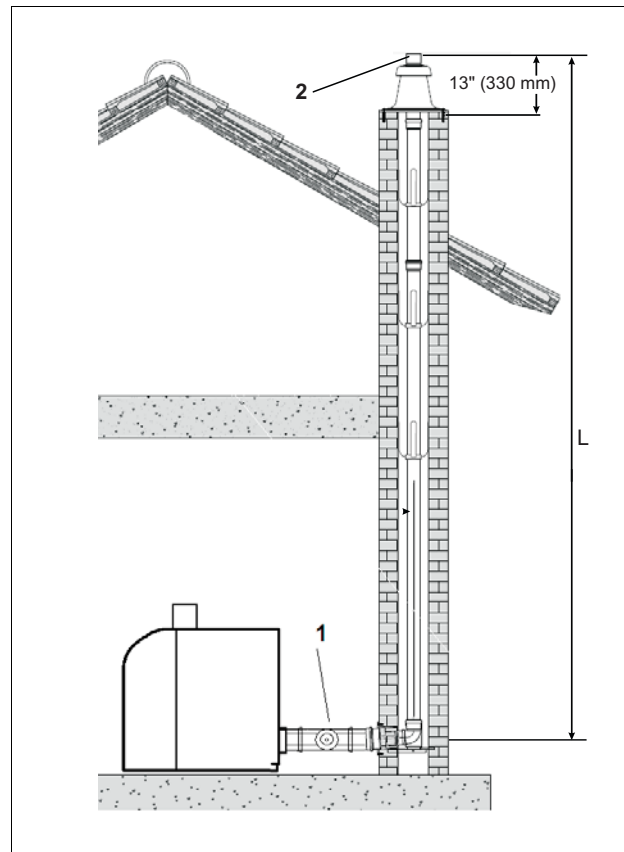

Fig. 8 Measure out pipe length (dimensions in mm)

- 1 Load bearing elbow
- 2 Termination

5.3.3 Insert flue gas pipe into the chimney

- Place the two halves of the spacer (Fig. 9, **Item 3**) on both sides around the pipe and put them together.



Attach a spacer at least every 6 ft. (2 m). Install an extra spacer within 3 ft. (1 m) of the chimney top.

- Coat gasket in the load bearing elbow and all flue gas pipes (Fig. 9, **Item 4**) with CENTROCERIN® anti-seizing compound.
- Turn slightly while assembling the pipes.

- Fasten mounting cable on the pipe or load bearing elbow.
- Insert flue gas pipe from above into the chimney (Fig. 10), until the pipe sleeve is a little above the upper edge of the chimney.
- Fasten the spacer on the next flue gas pipe. Coat the gasket with CENTROCERIN® anti-seizing compound and insert pipe into the sleeve.
- Lower flue gas line into the chimney. Repeat the procedure for all other pipes.
- Insert termination (without sleeve) into the last pipe with sleeve.



RISK OF DAMAGE TO SYSTEM
due to UV radiation.

- Use only the included UV-resistant black pipe as the termination.

- Place load bearing elbow in the middle on the support rail in the chimney.
- When using the flexible liner UB-Flex for parts or the complete length of the chimney, install spacers at every rigid section.

5.3.4 Installing the chimney cover

- Remove the upper part of the chimney cover (Fig. 11, **Item 1**).
- Push the lower part of the chimney cover over the terminating pipe.
- The chimney cover can be trimmed to size by cutting along the lines (Fig. 11, **Item 2**).
- Set cover on the chimney and mark 4 drill holes. Drill holes and insert wall anchors.
- Screw on chimney cover and caulk around the perimeter to prevent water from entering the chimney.
- Push upper part of the chimney cover over the flue gas pipe and press down until it snaps in.

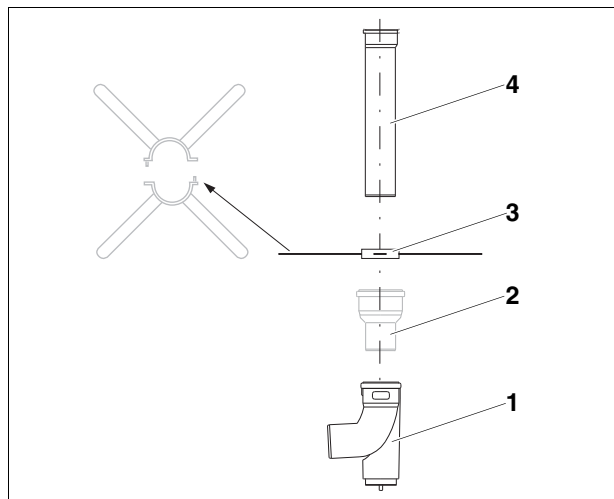

Fig. 9 Installing spacer

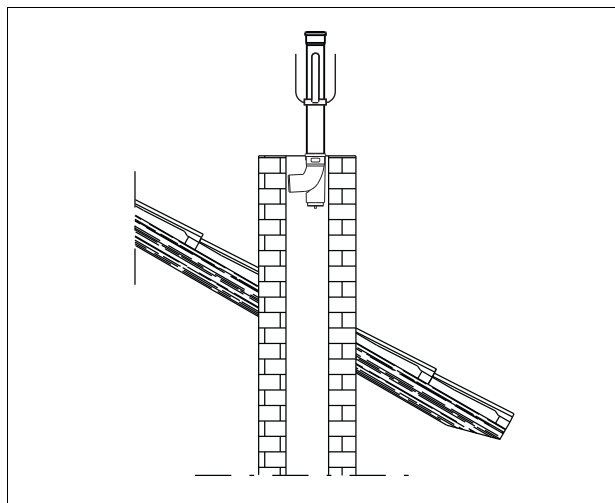

Fig. 10 Insert flue gas pipe into the chimney

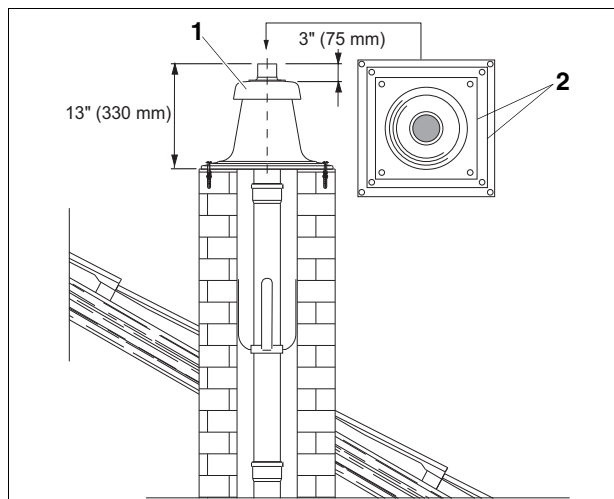

Fig. 11 Installing the chimney cover (dimensions in mm)

- 1 Upper part of the chimney cover (rain cap)
- 2 Cut lines

5.4 Establishing chimney connection

5.4.1 Install concentric wall penetration

- Coat gasket in the sleeve of the flue gas pipe (Fig. 12, **Item 2**) of the concentric wall penetration with CENTROCERIN® and insert flue gas pipe into the load bearing elbow.
- Shorten the penetrating pipe and flue gas pipe so it extends beyond the chimney wall by 2" (50 mm) (Fig. 12).
- Carefully remove the burrs from cut edges.
- Verify that all parts in the chimney are properly assembled.
- Mortar the penetrating pipe in place.
- Slide on the cover plate (Fig. 12, **Item 1**), mark and drill mounting holes, insert wall anchors, and screw on cover plate.

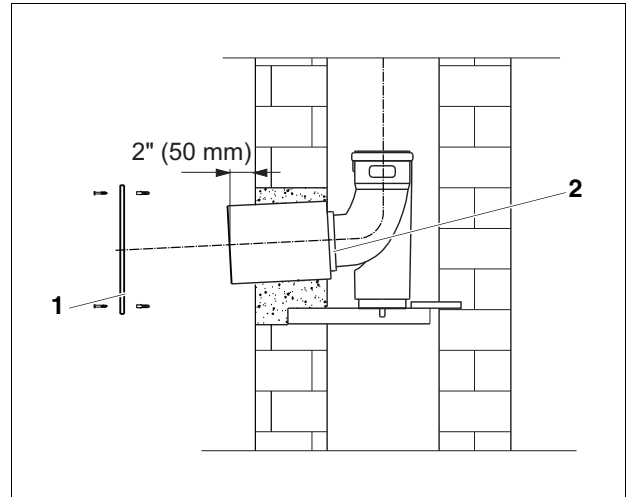

Fig. 12 Establishing chimney connection (dimensions in mm)

- 1 Cover plate
- 2 Flue gas pipe of the concentric wall penetration

5.4.2 Establishing the connection to the boiler

- Connect the inspection and clean-out pipe to the boiler adapter. Then measure the remaining distance to the chimney penetration, cut a concentric pipe to length, deburr, and install via concentric pipe with the concentric wall penetration (Fig. 13).
- When covering longer distances, support the pipe at least every 6' (2 m) (Fig. 13, **Item 1**).

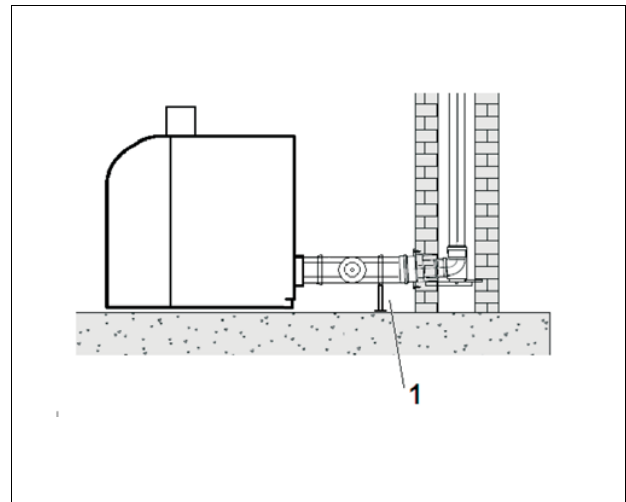

Fig. 13 Connecting boiler with chimney connection

- 1 Fastening clamps with standoff

5.5 Appliance connection

To install the appliance connector on the boiler identify the gasketed connection in the bottom right corner on the back of the boiler.

Apply CENTROCERIN® anti-seizing compound on the gasket of the secondary heat exchanger, and push the adapter on with a slight turning motion. The combustion air pipe should be oriented in a 10-o'clock position with all 3 predrilled screw holes visible.

Use the 3 brackets and self tapping screws in the pre-drilled screw holes to attach the adapter to the rear boiler panel.

Connect the combustion air hose to the adapter and secure with the provided hose clamp.

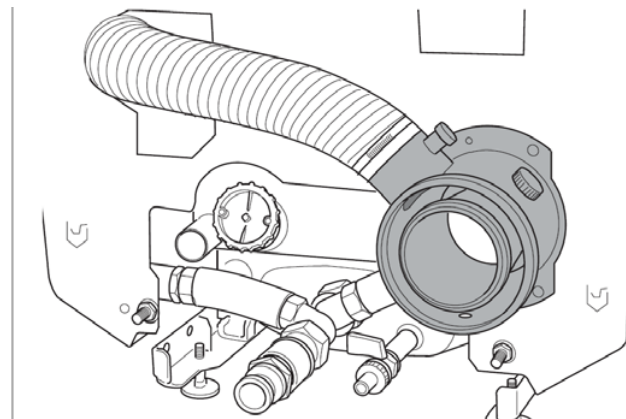

Fig. 14 Installing the boiler adapter

6 Inspecting the flue gas system

To make sure that no leaks occur during operation, the heating system must be checked for leaks before start-up.



RISK OF FATAL INJURY

from flue gas poisoning.

Leaky flue gas lines may cause dangerous flue gas leaks.

- Take the boiler out of operation until the leak in the flue gas line has been eliminated.

The flue gas line is sufficiently tight if the combustion air intake at the boiler adapter measures no higher than 0.2% CO₂, or a minimum of 20.6% O₂ (ring gap test).

Carry out the measurement over several minutes in order to avoid measurement errors. If the measurement produces a higher CO₂ value or a lower O₂ value, then a pressure test is required.

United States and Canada

Bosch Thermotechnology Corp.
50 Wentworth Avenue
Londonderry, NH 03053
Tel. 603-552-1100
Fax 603-584-1681
www.buderus.net

Products manufactured by
Bosch Thermotechnik GmbH
Sophienstrasse 30-32
D-35576 Wetzlar
www.buderus.de

Bosch Thermotechnology Corp. reserves the right to make changes without notice due to continuing engineering and technological advances.

Buderus