



7 747 010 678-00:1RS



## Logano G125 BE US/CA

For the Owner

Please read carefully before  
operating equipment.

**1 For your Safety . . . . . 3**

1.1 Regarding this Manual . . . . . 3

1.2 Proper Application Description . . . . . 3

1.3 Description of Symbols. . . . . 3

1.4 Observe the following Guidelines . . . . . 3

    1.4.1 Directions regarding Boiler Room . . . . . 3

**2 Product Description. . . . . 4**

2.1 Proper Application Description . . . . . 4

2.2 Product Description. . . . . 4

**3 Operation of the Heating System. . . . . 5**

3.1 Prior to System Start-up . . . . . 5

3.2 Testing of System Pressure, Filling and Venting of System . . . . . 5

    3.2.1 When should you check the system pressure? . . . . . 5

    3.2.2 Testing system pressure . . . . . 5

    3.2.3 Filling the System and Air Bleeding . . . . . 5

3.3 Start-up using the Control System. . . . . 7

3.4 Shutting down the System. . . . . 7

3.5 Emergency Situations . . . . . 8

3.6 Important Operational Information. . . . . 8

3.7 Importance of regular maintenance . . . . . 9

**4 Trouble Shooting of your Heating System. . . . . 10**

Operating Pressure	
Maximum Operating Pressure (Standard = 30 psi)	_____ psi
Maximum Operating Pressure (Standard = 30 psi)	_____ psi

Only use this fuel type:	
#2 Fuel oil ASTM D396-05 Type 2	
Stamp/Date/Signature	

**Manufacturer’s address:**

BBT North America Corporation  
 50 Wentworth Avenue  
 Londonderry, New Hampshire 03053, USA

Phone: (603) 552-1100

Internet: www.buderus.net

**Never use gasoline, kerosine, crank case oil, or other fuels unless specified above!**

# 1 For your Safety

## 1.1 Regarding this Manual

This manual contains important information regarding safe and proper operation of your boiler.

The high tech G125BE oil boiler is designed as a hot water heating boiler.

## 1.2 Proper Application Description

The boiler is certified as a hot water heating boiler for use in space heating and domestic hot water heating using an indirect fired hot water tank for single and multiple family homes.

## 1.3 Description of Symbols

The following symbols are displayed in this manual:



**WARNING!**

### DANGER TO LIFE

Denotes a potential danger that can lead to bodily injury or death.



**CAUTION!**

### PERSONAL INJURY/ SYSTEM DAMAGE

Denotes a potentially dangerous situation that can lead to bodily injury or property damage.



### NOTICE

Denotes a suggestion for optimum use and other useful information.

→ Cross reference

Cross references a particular point or another document with an arrow → .

## 1.4 Observe the following Guidelines

You will learn to properly operate your heating system when:

- Follow the instructions of your heating contractor during the start-up of the system.
- Read these operating instructions carefully.

Perform only those operations to your heating system that are described in this manual.



**WARNING!**

### DANGER TO LIFE

from unqualified personnel.

- Please make sure that the installation, start-up and annual maintenance are performed only by a heating contractor or service company. Any electrical or fuel carrying parts require work by a certified individual with the proper qualifications.

### 1.4.1 Directions regarding Boiler Room



**WARNING!**

### DANGER TO LIFE

from flue gas poisoning.

Insufficient combustion and ventilation air during room air operation of the equipment can lead to dangerous flue gases.

- Make sure that the ventilation and air supply and exhaust openings are always fully open and never plugged.
- Keep door(s) to the boiler room always closed.
- Protect the boiler room and specifically the ventilation and intake air openings from animals by means of louvers and/or screens.
- If the above issues are not resolved, the boiler must not be operated.



**WARNING!**

### FIRE DANGER

from flammable or combustible materials.

- Make sure that no flammable or combustible materials are stored near the boiler.

## 2 Product Description

### 2.1 Proper Application Description

The boiler can only be used as a hot water heating boiler for space heating, and domestic hot water heating using an indirect fired hot water tank for single and multiple family homes.

### 2.2 Product Description

The boiler is a low temperature oil fired model designed for maximum efficiency.

The boiler consists of the following components:

- Control System (Logamatic control or Honeywell aquastat)
- Boiler jacket panels
- Cast Iron Boiler block with Insulation
- Burner cover

The Logamatic control system monitors and controls the burner operation as well as several main components of the heating system.

As an alternative, the boiler can also be equipped with a Honeywell aquastat.

The boiler jacket serves as protection, insulation and noise control.

The cast iron boiler block transfers the heat produced by the burner to the boiler water. The insulation minimizes heat loss.

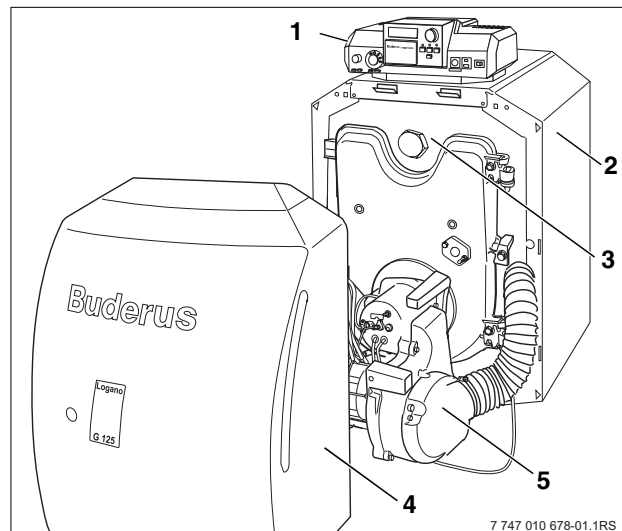

Fig. 1 G125 BE US/CA High Tech Oil Boiler

- 1 Control system (optional)
- 2 Boiler jacket panels
- 3 Cast Iron Boiler block with insulation
- 4 Burner cover
- 5 Burner

## 3 Operation of the Heating System

### 3.1 Prior to System Start-up

Check the following before engaging the system:

- That the system pressure is sufficient.
- That the main fuel supply valve is opened.
- That the boiler emergency switch is ON.

### 3.2 Testing of System Pressure, Filling and Venting of System

#### 3.2.1 When should you check the system pressure?

It is recommended to check the system pressure on newly installed systems frequently during the first week of operation, as the volume might be slightly reduced due to air pockets being eliminated from the system.

- Check the system pressure of a new system daily, and add boiler water when needed. Possibly vent the system at radiators if applicable.
- Later check the system pressure monthly, add boiler water when needed. Vent the system at radiators if applicable.

#### 3.2.2 Testing system pressure

The system pressure should be a minimum of 12 to 15 psi.

The target value for the system can be read on →Page 2 (To be filled out by the installing contractor).

- The actual pressure and temperature can be read at the pressure/temperature gauge.
- When the system pressure drops below 12 to 15 psi, adding water to the boiler system is recommended.

#### 3.2.3 Filling the System and Air Bleeding

Please ask your heating contractor or service company to demonstrate to you how to add boiler water to the system and how to vent the system.



**CAUTION!**

#### **HEALTH DANGER**

from contamination of drinking water with boiler water.

- Please request that your heating contractor or service company shows you how to properly add water to the boiler system.

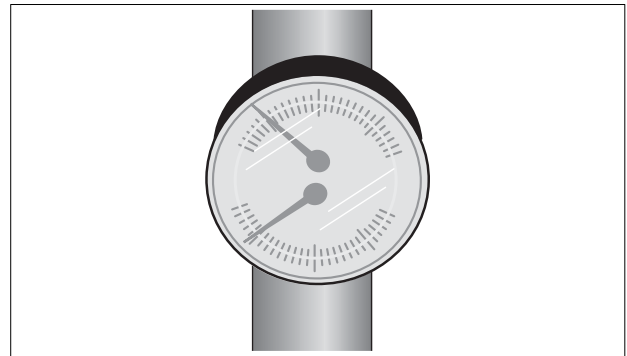

Fig. 2 Pressure/temperature gauge (located at the rear of the boiler).

**SYSTEM DAMAGE**

due to temperature swings.

**CAUTION!**

When the water is added to a hot boiler, thermal stresses can occur.

- Add fill water to the boiler when the boiler is cold (The boiler temperature must not exceed 100 °F).

- Fill the heating system slowly via the automatic feed valve. Pay close attention to the pressure gauge.
- Stop adding fill water, when the desired pressure is reached.
- Vent the system via radiator air bleeding valves where available.
- When the system pressure drops following the air venting, add additional water.

**SYSTEM DAMAGE**

due to frequent filling.

**CAUTION!**

When you have to add water on a regular basis, the system might get damaged due to lime stone build-up and corrosion.

- Check with your heating contractor if the boiler water requires treatment.
- Please inform your heating contractor if you frequently need to add water to the boiler.

### 3.3 Start-up using the Control System

Turn the system on using your control panel. The burner will automatically activate when you turn on the control panel. The burner can also be started up from the control panel. Further information can be obtained from the operating manual of the control panel or burner.

- Set the adjustable boiler aquastat to position "AUT" (ON).
- Turn the main switch to "I" (ON).



#### NOTICE

- You will find information regarding operation, e.g. setting of temperatures, in the → documentation of the respective controls.

#### Heating System Operation with Aquastat

- Turn boiler switch to "ON" position. This turns the system on.

### 3.4 Shutting down the System

#### With Buderus control (Fig. 3)

- Turn main control switch to "OFF" (Position "O"). This shuts off the boiler and all operating components.

#### With Aquastat (Fig. 4)

- Shut off boiler switch (Position "OFF"). This shuts off the entire heating system.
- Shut off oil supply by closing the main fuel valve.



#### CAUTION!

#### SYSTEM DAMAGE

from freezing.

When the heating system is not in operation, the system can freeze up.

- Keep your heating system in good operating order.
- If the system is not operational and temperatures in the building can get close to freezing, protect the system from freezing by draining the heating and DHW pipes at their lowest point.

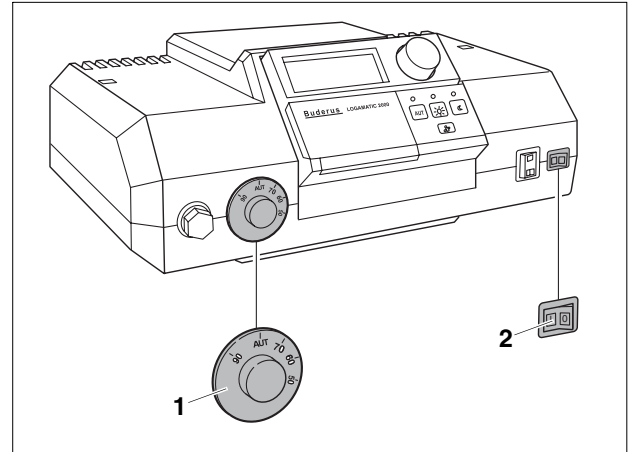

Fig. 3 Turning on the control panel (Logamatic 2000)

- 1 Adjustable Boiler Aquastat
- 2 Main Switch

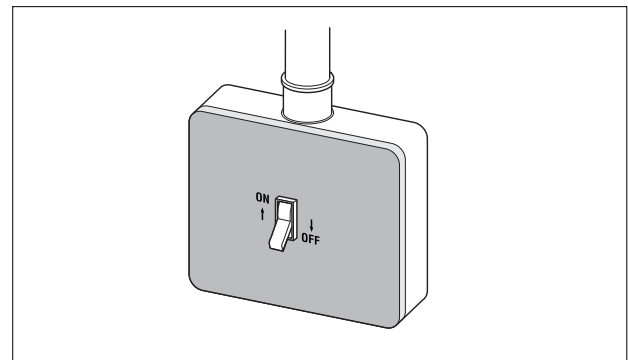

Fig. 4 Heating system operation with aquastat using main service switch (No Buderus control panel).

### 3.5 Emergency Situations

In case of an emergency, such as a fire, proceed as follows:

- Shut off oil supply using main shut-off valve.
- Shut off the system electrically with the main service switch or by disengaging the heating system circuit breaker.

### 3.6 Important Operational Information

#### The proper fuel

For trouble free operation, the heating system requires the correct fuel and fuel quality.



**CAUTION!**

#### SYSTEM DAMAGE

from incorrect fuel.

- Use only listed fuel.

Use of unlisted fuel can lead to service calls, can cause damage to burner, boiler and the venting system and may void Buderus' warranty.

#### Boiler Room



**CAUTION!**

#### BOILER DAMAGE

due to contaminated combustion air.

- Never use or store cleaning agents containing chlorine or hydro-carbons (eg. Spray cans, solvents, paints, cleaning agents) in the boiler room.
- Avoid dust generation and build-up.



**CAUTION!**

#### BOILER DAMAGE

from flooding.

- In case of flood conditions, disconnect the boiler electrically and fuel wise (→ Chapter 3.4, page 7).
- Have your contractor check your system, following flood conditions.
- Components, such as valves, control and electrical parts that have been in contact with water must be replaced by a heating contractor.

Use only the following fuel
<b>#2 Fuel oil ASTM D396-05 Type 2</b>
<hr/> Stamp/Date/Signature

### 3.7 Importance of regular maintenance

Heating systems require annual maintenance for the following reasons:

- To maintain high efficiency level and ensure efficient system operation (low energy use).
- To ensure high reliability of the system.
- To maintain low emissions.



**CAUTION!**

#### **SYSTEM DAMAGE**

due to incomplete cleaning or unqualified maintenance.

- Make sure to have your heating system serviced, cleaned and maintained annually by a certified contractor or heating company.
- Buderus recommends signing up for a service agreement for annual maintenance.

## 4 Trouble Shooting of your Heating System

Two types of failures can be identified:

- Burner failures and
- Failures of the control system and heating system.

The reset light will be lit on the burner to indicate a burner failure (→ refer to Burner Manual). The failure can typically be resolved by pressing the reset button on the burner.

Failures of the control system or heating system are typically shown on the control's display, provided the boiler is equipped with a digital control panel. Further information can be found in the → Operating Manual of the control.

### Resolving burner failures

- Press the burner reset button.



**CAUTION!**

#### SYSTEM DAMAGE

Frequent pressing of the reset button can lead to damage to the ignition system.

- Do not press the reset more than three times. If the burner does not function properly after three trials, review the burner manual for details. Contact your heating contractor or service company.



**CAUTION!**

#### SYSTEM DAMAGE

from freezing.

When the heating system is not in operation due to a failure, the system can freeze up.

- Have the failure corrected immediately and start up the system again.
- Protect the system from freezing by draining the heating and DHW pipes at their lowest point.

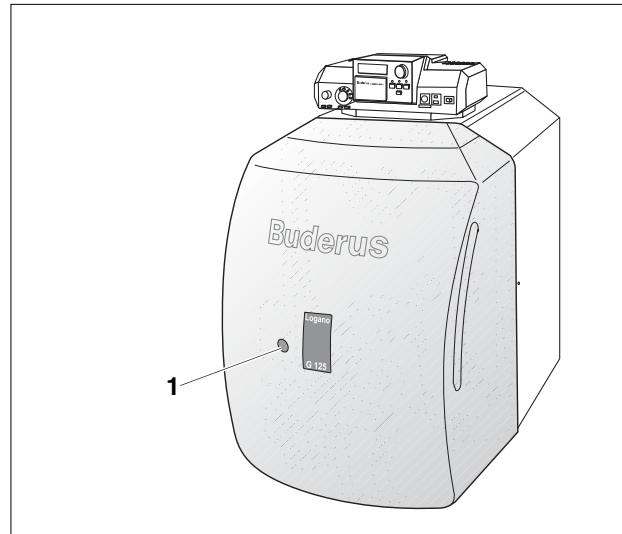

Fig. 5 Resetting the burner.

1 Reset button



BBT North America Corporation  
50 Wentworth Avenue  
Londonderry, NH 03053  
Tel. 603-552-1100  
Fax 603-584-1681  
[www.buderus.net](http://www.buderus.net)

Products manufactured by  
BBT Thermotechnik GmbH  
D-35573 Wetzlar  
[www.buderus.de](http://www.buderus.de)

BBT North America Corporation reserves the right  
to make changes without notice due to continuing  
engineering and technological advances.

**Buderus**