

HT-K - Horizontal Flue Gas System For GB125 Oil Condensing Boiler

For trained and certified
Installers

Please read carefully prior
to installation.

| | | |
|----------|--|-----------|
| 1 | General information | 3 |
| 1.1 | Standards, regulations and directives. | 3 |
| 1.2 | System certification | 3 |
| 2 | Safety | 4 |
| 2.1 | About these instructions | 4 |
| 2.2 | Intended use | 4 |
| 2.3 | Layout of the instructions | 4 |
| 2.4 | Please follow these instructions | 4 |
| 2.5 | Tools, materials and accessories | 4 |
| 2.6 | Disposal. | 4 |
| 3 | Product description, scope of delivery and technical data | 5 |
| 3.1 | HT-K Basic Kit (DN125/80) | 5 |
| 3.2 | Technical data | 5 |
| 4 | Notes on installation and operation. | 6 |
| 4.1 | Installation requirements for the boiler room. | 6 |
| 4.1.1 | Balanced flue operation (HT-K) | 6 |
| 4.2 | Condensate drain | 6 |
| 4.3 | Safety distances to combustible material. | 6 |
| 4.4 | Recommended vent/air intake terminal position | 6 |
| 4.5 | Instructions for inspection and clean-out sections | 8 |
| 4.5.1 | Inspection and clean-out sections | 8 |
| 4.5.2 | Arrangement of the inspection and clean-out section | 8 |
| 5 | Installing the flue gas system | 9 |
| 5.1 | General installation notes | 9 |
| 5.2 | Appliance connection. | 10 |
| 5.3 | Installation and final assembly | 10 |
| 6 | Inspecting the flue gas system | 11 |

1 General information

1.1 Standards, regulations and directives

It is the responsibility of the installer to ensure that the system corresponds to all current regulations and rules.

This flue gas system is only approved for the GB125. Use with other boilers is not permitted.

Only use parts of this flue gas system and do not combine it with other systems.

1.2 System certification

For Logano plus GB125 oil condensing boilers:

The GB125 is system-certified with this flue gas system for the USA and Canada.

An individual approval of the flue gas system is not required.

The flue gas system must be installed in accordance with these installation instructions. The maximum permissible overall length and the number of changes of direction are specified in the "Technical data" section.

In the Commonwealth of Massachusetts install CO detectors per 527 CMR 31.00.

2 Safety

2.1 About these instructions

These installation instructions contain important information for the safe and appropriate installation and start-up of the flue gas systems.

These installation instructions are designed for specialists, who - through their vocational training and experience - are knowledgeable in the handling of heating systems and oil installations.

2.2 Intended use

The basic kit HT-K may be used as flue gas system for Buderus oil condensing boilers with maximum flue gas temperatures of 248 °F (120 °C). Suitable are boilers of the types:

- Logano plus GB125-22/30/35

2.3 Layout of the instructions

Two levels of danger are identified and signified by the following terms:



WARNING!

RISK OF FATAL INJURY

Identifies possible dangers emanating from a product, which might cause serious injury or death if appropriate care is not taken.



WARNING!

RISK OF INJURY/SYSTEM DAMAGE

Indicates a potentially dangerous situation that could cause minor or moderately serious injuries and damage to property.

Additional symbols for identification of dangers and user instructions:



USER NOTE

User tips for optimal use of equipment and adjustment as well as other useful information.

2.4 Please follow these instructions



WARNING!

RISK OF FATAL INJURY

FROM FLUE GAS POISONING.

Insufficient ventilation or leaky flue gas lines may cause dangerous flue gas leaks.

- Make sure that air intake or exhaust air vents are not closed off or their size reduced.
- The boiler must not be operated until the obstruction has been removed.
- Inform the system user in writing of the fault and its associated dangers.



Only use original Buderus spare parts. Damage caused by the use of parts not supplied by Buderus is excluded from the Buderus warranty.

2.5 Tools, materials and accessories

For the installation of the boiler, you will require the standard tools used for central heating and oil and water systems.

2.6 Disposal

- Dispose of the packaging of the flue gas system in an environmentally responsible manner.
- Dispose of components of the flue gas system that are replaced through an authorized agent in an environmentally responsible manner.

3 Product description, scope of delivery and technical data

3.1 HT-K Basic Kit (DN125/80)

The HT-K flue gas system is a concentric pipe-in-pipe system of plastic and steel. The outer concentric pipe is a combustion air pipe, the inner pipe carries the flue gases.

Only one boiler may be connected to the flue pipe.

Before starting any installation work, check that all listed items are present.

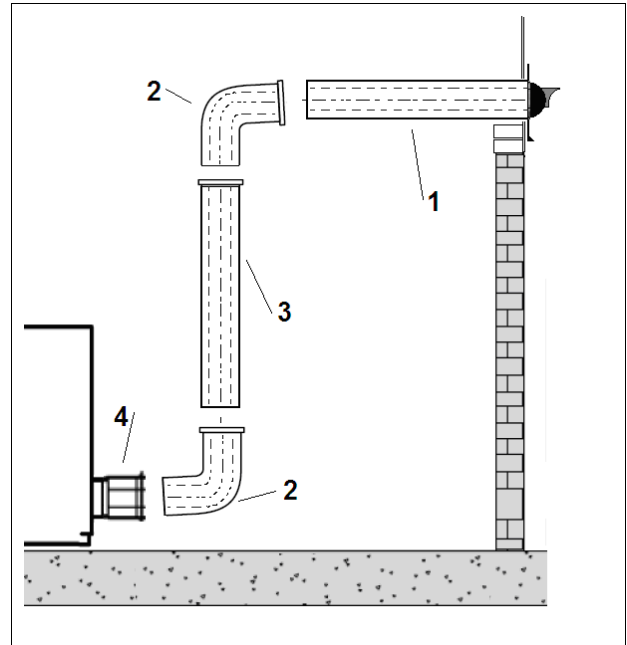

Fig. 1 Contents

| | | |
|---|---|-----|
| 1 | Concentric Termination | 1 × |
| 2 | Concentric elbow DN125/80 87° | 2 × |
| 3 | Concentric pipe 39" (1000 mm) | 1 × |
| 4 | Boiler adapter | |
| | CENTROCERIN® anti-seizing compound (not shown) | 1 × |

Purchase additional extension pieces to complete the installation.

3.2 Technical data

| Flue system | Logano plus GB125 | | |
|-------------|-------------------|----------------|----------------|
| | 22 | 30 | 35 |
| HT-K | 17 ft. (5.2 m) | 17 ft. (5.2 m) | 17 ft. (5.2 m) |

Tab. 1 Maximum overall lengths and minimum chimney flue diameters

Pipe changes of direction

The overall lengths apply for systems with one elbow.

An additional elbow (accessory) reduces the maximum vent length by 3 ft. (1 m).

4 Notes on installation and operation

4.1 Installation requirements for the boiler room

4.1.1 Balanced flue operation (HT-K)

The GB125 is designed for balanced flue operation only.

All combustion air is taken in from outside.

Installation and service of Buderus HT-K concentric vent systems must be performed by a qualified installer.

Never connect this concentric vent into a common vent system.

4.2 Condensate drain

The boiler has an integrated condensate drain in the secondary heat exchanger. The condensate from the vent pipe flows directly into the boiler's trap (siphon).

Follow local rules when draining condensate into municipal sewage systems.

It is not recommended to drain untreated condensate in septic systems.

In any case follow local codes and regulations.

Consult the boiler installation instructions for details on installing a condensate neutralizer.

- Slope horizontal vent pipe 1/4 inch per foot (20 mm per meter) toward the appliance

1. The vent system must be inspected annually for signs of damage or condensate leaks. If the vent system appears damaged the appliance must be turned off and the vent system repaired.

2. The horizontal termination may not be located above a public walkway, driveway or area where condensate or vapor could create a nuisance or hazard.

3. Ice can develop in regions of cold climate. A 1/4 inch per foot (20 mm per meter) pitch to the appliance is recommended (Buderus can not be held liable for personal injury or property damage due to ice formation).

4.3 Safety distances to combustible material

The design of the concentric venting system allows installation with zero (0", 0 mm) clearance. Therefore, no particular protective measures or safety distances are required for combustible material or furniture.

4.4 Recommended vent/air intake terminal position

Terminals should be so positioned as to avoid products of combustion entering openings into buildings or other flues or vents. The Buderus concentric vent is designed for indoor use only. Only the tip of the termination is protected from UV-radiation (direct sunlight). None of the other pipes or elbows may be installed outdoors.



VORSICHT!

Risk of Life from flue gas POISONING

Maintain 12" of clearance above the highest anticipated snow level or grade or whichever is greater.

Refer to your local codes for the snow level in your area.

Choice of installation site for side-wall flue termination

Choosing the right location for siting the terminal is critical to proper and safe operation of the appliance. Besides the minimum clearances (Fig. 2), the following rules must be observed:

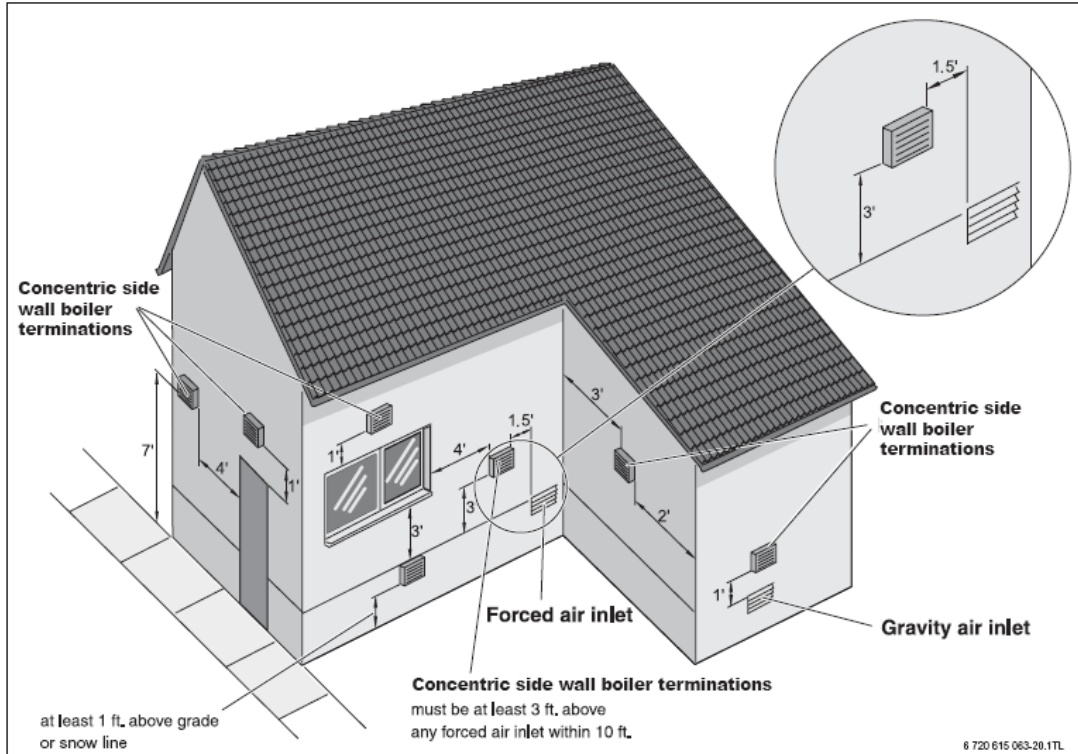

Fig. 2 Minimum clearances for side wall terminations

1. The termination should not face the prevailing wind direction.
2. The termination must be installed in such a way that the flue gases can disperse freely without re-entering the building.
3. The termination must be at least 2 ft (0.6 m) from adjacent buildings and it must not be possible for the flue gas to enter adjacent buildings.
4. Where the building adjoins public walkways, the termination must be located at least 7 ft (2.1 m) above ground. Make sure that freezing condensate does not constitute a nuisance or hazard.
5. The termination must never be located below building overhangs, roof eaves, porches, enclosed spaces or lower parts of the building which could prevent unrestricted outflow of the flue gases.
6. The termination must never be located within 3 ft (0.9 m) of inside corners of buildings and never less than 2 ft (0.6 m) from outside corners of buildings.
7. If there is a fan-assisted air intake vent within 10 ft (3.3 m), the termination must be at least 3 ft (0.9 m) above it.
8. The termination must be at least 4 ft (1.2 m) below, 1 ft (0.3 m) above or 4 ft (1.2 m) horizontally from doors, windows or air inlet vents.
9. The termination must be at least 1 ft (0.3 m) above ground and snow line, and protected from falling and accumulating snow, ice, leaves or debris.
10. The termination should be at least 3 ft (0.9 m) from any type of building opening, oil tank filling or venting apparatus, and 6 ft (1.8 m) from gas meters and similar equipment.
11. The position of the termination should be chosen so that all horizontal pipes slope downward to the boiler at $\frac{1}{4}$ " per ft (20 mm per meter). The flue terminal itself must also be sloped at $\frac{1}{4}$ " per ft (20 mm per meter) to the inside so that any condensate drains inward (Fig. 3).

4.5 Instructions for inspection and clean-out sections

4.5.1 Inspection and clean-out sections

Local codes and regulations may require an inspection and clean-out section to be installed close to the boiler.

Inspection and clean-out sections allow inspecting and cleaning the venting system without dismantling sections of it.

4.5.2 Arrangement of the inspection and clean-out section

An inspection and clean-out section must be installed sideways in the horizontal section of the flue gas pipe as the first section after the boiler adapter (Fig. 3, Item 1).

Keep area of at least 3 ft. x 3 ft. (1 m x 1 m) clearance in front of the inspection section for easy access.

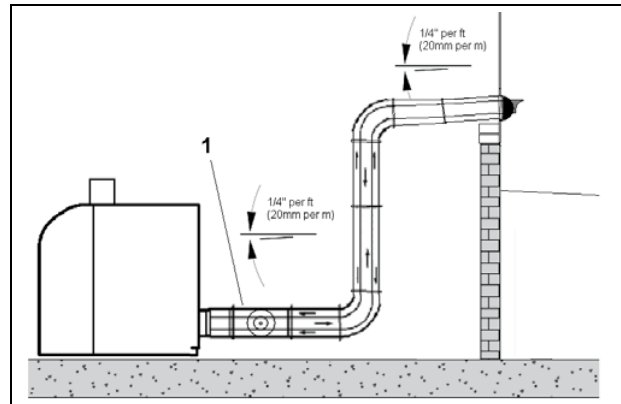

Fig. 3 Location of clean-out section and slope of pipes

1 Clean-out section

5 Installing the flue gas system

5.1 General installation notes



WARNING!

Risk of death from leaking flue gases

- Improper installation of vent system and components or failure to follow all installation instructions can result in property damage or serious injury.

Trimming pipes



WARNING!

RISK OF INJURY

- from sharp edges.
Wear work gloves.

- With concentric pipes, pull the inner pipe out of the outer pipe in the direction of the gasketed side.
- Trim pipes at a right angle to the required length x (Fig. 3).
- With concentric pipes, trim flue gas and air intake pipe to the same length.
- Carefully remove burrs from cut edges otherwise the gaskets might get damaged, which can result in the system no longer being air tight.
- Put the flue gas and air intake pipes together again.

Installing the pipe connection

Assemble the pipes so that the sleeve points in the direction of the flue gas stream, with the gasket on the far side of the pipe when viewed from the boiler. Only use original Buderus flue gas pipe gaskets!

- Coat the gaskets (Fig. 4, Item 1) with CENTROCERIN® anti-seizing compound.
- Push the flue gas pipes into one another (Fig. 4, Item 2) with a slight turning motion until the stop.

With concentric pipes, push the air intake pipe (outer pipe, Fig. 4, Item 3) together to ensure a tight fit.

Verify that the gaskets did not shift.

Loosening the pipe connection

- Pull the pipes out of one another while turning slightly.

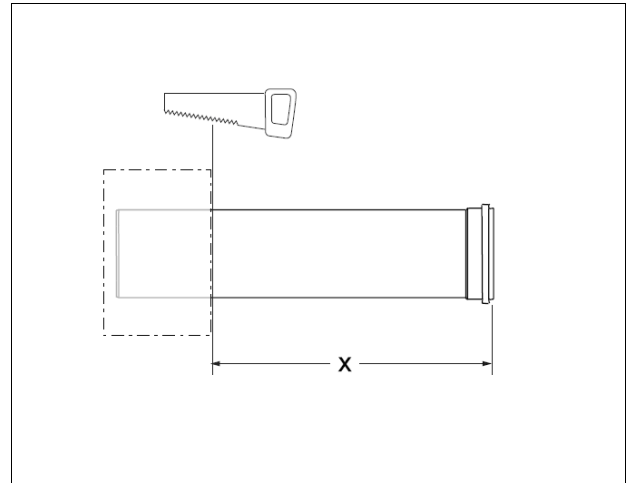

Fig. 4 Cutting the concentric pipe

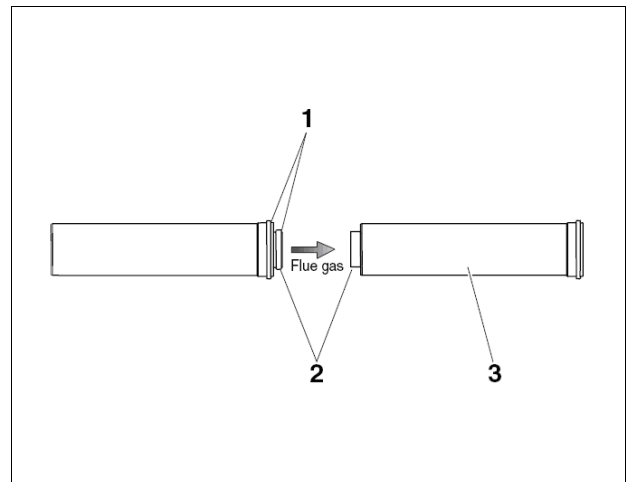

Fig. 5 Assembly of two concentric pipes

- 1 Location of the gaskets
- 2 Flue gas pipe
- 3 Outer combustion air pipe

5.2 Appliance connection

To install the appliance connector on the boiler identify the gasketed connection in the bottom right corner on the back of the boiler.

Apply CENTROCERIN® anti-seizing compound on the gasket of the secondary heat exchanger, and push the adapter on with a slight turning motion. The combustion air pipe should be oriented in a 10-o'clock position with all 3 predrilled screw holes visible.

Use the 3 brackets and self tapping screws in the pre-drilled screw holes to attach the adapter to the rear boiler panel.

Connect the combustion air hose to the adapter and secure with the provided hose clamp.

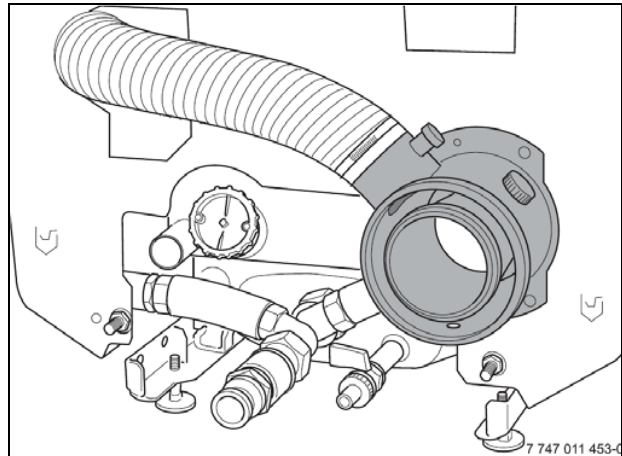

Fig. 6 Installing the boiler adapter

5.3 Installation and final assembly

Steps:

- (1) Identify location of the termination per the instructions of 4.4
- (2) Cut an opening in the wall slightly larger than black end of the termination.
- (3) Insert termination from outside and ensure it is slightly pitched to the inside.
- (4) Apply ample caulk to waterproof the penetration.
- (5) Install the foam gasket and flashing from the outside.
- (6) On the boiler install a clean out section immediately after the boiler adapter (if applicable).
- (7) Connect the termination with the clean out section using straight concentric pieces and concentric elbows as the installation site requires. Sections can be cut to length per the procedure shown in 5.1.
- (9) After cutting to the appropriate length, coat the gaskets with CENTROCERIN® anti-seizing compound and slide the pieces together by turning slightly.
- (8) Sections longer than 6 ft. (2 m) must be supported with bracing or clamps. Do not use the termination or the boiler adapter to support the venting system.

It is the installer's responsibility to ensure that the vent pipe is securely attached and supported as required by the site, and cannot accidentally disintegrate.

6 Inspecting the flue gas system

To make sure that no leaks occur during operation, the venting system must be checked for leaks before start-up. The flue gas line is sufficiently tight if the combustion air intake at the boiler adapter measures no higher than 0.2% CO₂, or a minimum of 20.6% O₂ (ring gap test).



WARNING!

Risk of flue gas poisoning

Leaky flue gas lines may cause dangerous flue gas leaks.

- Take the boiler out of operation until the leak in the flue gas line has been eliminated.

Carry out the measurement over several minutes in order to avoid measurement errors. If the measurement produces a higher CO₂ value or a lower O₂ value, then a pressure test is required.

United States and Canada

Bosch Thermotechnology Corp.
50 Wentworth Avenue
Londonderry, NH 03053
U.S.A.
Tel. 603-552-1100
Fax 603-584-1681
www.buderus.net

Products manufactured by
Bosch Thermotechnik GmbH
Sophienstrasse 30-32
D-35576 Wetzlar
www.buderus.de

Bosch Thermotechnology Corp. reserves the right
to make changes without notice due to continuing
engineering and technological advances.

Buderus