



## **Superior Equipment by Design**

- High Efficiency - Combustion Efficiencies Up To 88%
- Thermostream Design Eliminates Thermal Shock
- Flexible, Corrosion Resistant GL-180M Cast Iron
- Full Swing Reversible Burner Door for Excellent Serviceability
- 350 to 3,982 MBH Output

**Comfortable. Efficient. Intelligent Heating.**

# G315-G515-G615

## A Better Way to Heat

The Buderus commercial Thermostream boilers are designed with many physical attributes setting them above the competition and increasing their longevity and efficiency. The burner doors are field adjustable to swing fully open from either side, to enable the boilers to fit in any location. These boilers are shipped knocked down for easy transport, the G315 and the G515 can also be shipped as an assembled block. Due to the unique chamber design, no refractory materials are used. This reduces the number of service calls and maximizes heat transfer. Buderus precision castings eliminate the need for manual grinding. Precision beveled steel push nipples join cast iron sections and high temperature flue sealants are used to sustain pressurized operation.



The G315 and G515 come with a full 3 ½" of thermal insulation, and the G615 comes with a full 4" of thermal insulation to reduce standby heat loss. All Buderus cast iron commercial boilers are manufactured with the Buderus GL-180M cast iron with a silicon "barrier skin." To streamline the appearance of the boilers, the supply and return connections for the G315 are located at the rear of the boiler, while the G515/G615 have top supply and a rear return. These boilers are for use with hot water and can be installed with gas, oil or dual fuel burners.

## Intelligent Heating – by design

Buderus, the world leader in heating technology, manufactures the highest quality boilers based on centuries of experience. With its innovative design and quality manufacturing, a Buderus boiler will outlast and out-perform virtually any other commercial hot water boiler system in the world.

The G315, G515 and G615 are designed to maximize the heating value of every ounce of fuel and are built with the highest quality materials. Established in 1731, Buderus uses state-of-the-art techniques in the design and manufacturing of its boilers.

## Thermostream Design

The Buderus developed **Thermostream** principle is proven for higher efficiency and improved system reliability in high volume heating systems. Condensation and thermal shock are made impossible by design, as cool return water mixes internally and is preheated with supply water before exposure to directly heated surfaces. This process eliminates hot and cold spots in the boiler and balances water flow throughout all boiler sections. The **Thermostream** design permits continuous low temperature operation under normal return water without requiring a minimum boiler return temperature. Internal water circulation and injection into each boiler section combined with deflection plates ensure condensate free boiler operation—even under no flow conditions.



## Design Benefits

- Eliminates the need for bypass loop or shunt pump.
- Eliminates hot and cold spots in the boiler.
- Minimizes thermal stresses in each section.
- Allows operation at low return water temperatures without thermal shock concerns.
- Minimum supply temperature of 122° F with standard control.
- Ensures balanced water flow through all boiler sections.

1-800-283-3787

283-3787

## Boiler Construction

The boiler sections are assembled with beveled, surface profiled push nipples for long, trouble-free watertight operation. Boiler flue ways are manufactured to be gas tight with tongue and groove section design and elastic, high temperature resistant sealing rope. This seal is fully pressed into the groove during assembly to allow positive pressure operation. A permanent dry door gasket ensures repeated positive sealing of the full swing burner door. Because flue gases cannot escape through the seams between boiler sections, the boilers are able to retain heat more efficiently.

## GL-180M Gray Cast Iron:



Buderus GL-180M silicone injected, gray cast iron obtains its superior material characteristics primarily from a high carbon (graphite) and silicone content. Buderus GL-180M gray cast iron has excellent corrosion resistance, exceptional casting characteristics, 40% greater flexibility and elasticity as well as high thermal conductivity. Buderus developed the special substances that are impregnated during the casting process to improve the mechanical properties of cast iron. The graphite precipitates into smaller, modified flakes which produce GL-180M cast iron with 40% greater elasticity and a high silicone barrier for corrosion protection. All sections are heat treated to relieve thermal stresses. Additional elements further enhance the properties of the GL-180M. The graphite appears in two different forms in the microstructure: nodular form producing excellent tensile strength and great elasticity and graphite flakes producing excellent corrosion resistance against acidic combustion products.

thermal stresses. Additional elements further enhance the properties of the GL-180M. The graphite appears in two different forms in the microstructure: nodular form producing excellent tensile strength and great elasticity and graphite flakes producing excellent corrosion resistance against acidic combustion products.

## Full Three Pass Design – for High Efficiency

Buderus developed the full three pass system to increase the heat transfer and efficiency of boilers. This design allows more heat to be transferred during all three passes, unlike conventional boilers that only use one pass to transfer heat. This system maximizes the total possible heat available with the lowest fuel consumption possible. To greatly decrease standby loss Buderus has manufactured an either 3 ½ or 4" thick thermal insulation.

## Parallel Piping

Boilers shall be piped in a reverse return arrangement to ensure equal flow through each boiler. A small thermal bypass shall be installed immediately after the FK supply sensor in order to create flow past the sensor when the system pump (PH) is off.

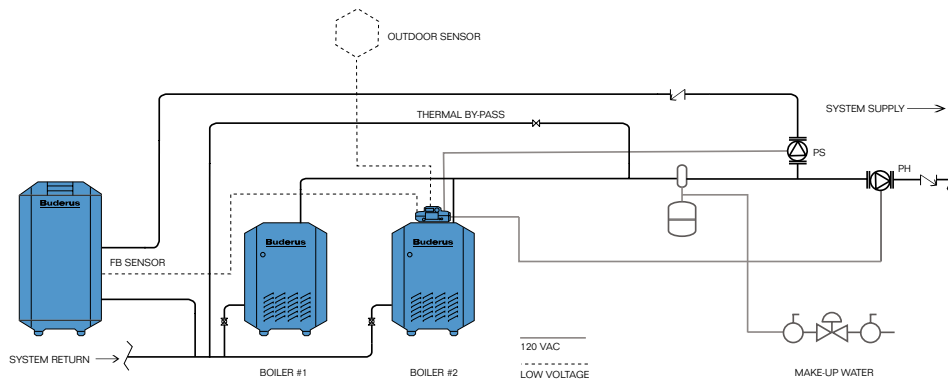

NOTE: This drawing is conceptual in nature and does not purport to address all design, installation or safety considerations.

## The Three-Pass Boiler is Designed for:

- Optimized combustion with positive pressure-fired boilers and tailored chamber geometry — no need for a heat-consuming refractory or target wall eliminating the need for costly repairs.
- Minimal stack losses with the modified three-pass flue design's large heat transfer areas.
- Low standby losses with a full 3½" to 4" jacket of thermal insulation around the entire block —even underneath the boiler!

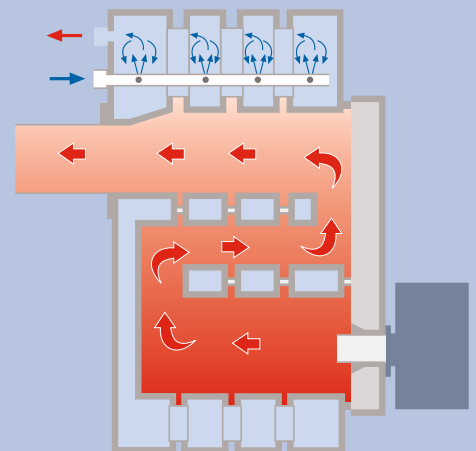

## How it works.

The flame fires into the first chamber. Then the flue products flow through the second pass to the front of the boiler. From there they reverse direction again — moving through the third pass to the back, and finally exiting via the flue connection into the chimney. Because the gases are held in the boiler longer this allows the cast iron to absorb the maximum amount of heat, resulting in a lower stack temperature and a higher efficiency.

## Complete Your System

Once you have a Buderus boiler, you can add a Buderus indirect fired hot water tank, an optional Buderus Logamatic Control or both. The Logamatic Control maximizes your comfort and fuel savings. It will also accommodate specialized heating applications such as radiant flooring. Combined, this premium heating system will provide years of exceptional comfort and economy.

## Convenient Logamatic Control

Logamatic Controls can be used to adjust the firing rates of burners in multi-boiler systems. Controls can be pre-programmed with automatic night and day functions and set to trigger automatic adjustments based on shifts in outdoor or indoor temperatures. An optional module is available for direct communication with building management systems.



### The 4000 Series - Multiple Boilers

The intelligent regulation of energy is the heart of any heating system. A Logamatic Control provides the ability to make finer adjustments than are possible by manually turning the boiler off and on or relying on traditional thermostats. Multiple design innovations increase the versatility of Buderus Logamatic Controls including the automatic adjustment between various modes of operation. A change in modes can be set to correspond with time, date or temperature. Modes can also be changed manually. All Logamatic Controls now include summer, winter and vacation modes which effectively regulate energy consumption. This regulation is effectual in single or multi-boiler systems, with any heat source and in accordance with one or multiple heating zones.



### The 2107 - Single Boiler

The Buderus Logamatic Controls, designed to work with all Buderus boilers, significantly increase the effectiveness of your heating system. The Controls easily maintain a comfortable environment by measuring indoor and outdoor temperatures in order to automatically and effectively regulate the temperature of the boiler. This allows the boiler to use less fuel while keeping the exact temperature you want. The Logamatic Controls also include the convenience of a setback feature for nighttime as well as a domestic hot water priority option. So, no matter how hard the heating has to work on a cold day, there will always be hot water for showers. All control functions are able to be customized by you. Additionally, the Buderus Logamatic R2107 is designed with a built-in self diagnostic system to aid in maintenance and reduce service costs.

## 4000 Series Logamatic Control



### Integrated multi-boiler system controller with the following features and optional control modules:

- Outdoor reset, staged burner operation.
- Control of single, two-stage and modulating burners. (Up to 3 boilers)
- Automatic and load/switch dependent burner rotation.
- Operation of boiler pumps, 2-way valves, 3 or 4-way valves and system pumps.
- BMS interface capability (list protocols).
- External load capability: DHW and other on-demand loads.
- Self diagnostics and system parameter display.

Model	G315/5	G315/6	G315/7	G315/8	G315/9
<b>Performance Data</b>					
Gross Output MBH	350	454	559	663	768
# of Sections	5	6	7	8	9
Max Input Gas MBH	433	556	678	801	924
Max Input Oil	3.0	3.85	4.7	5.6	6.4
Net IBR MBH	304	395	486	577	668
Boiler HP	10.4	13.6	16.6	19.8	22.9
Max Operating Pressure (psi)	87	87	87	87	87
Combustion Efficiency Oil	86.8%	86.9%	87%	87.1%	87.1%
Combustion Efficiency Gas	84.2%	84.3%	84.4%	84.4%	84.4%
<b>Piping Connections</b>					
Vent Connection Size	7"	7"	7"	7"	7"
Supply	3"	3"	3"	3"	3"
Return	3"	3"	3"	3"	3"
<b>Physical Dimensions</b>					
Overall Boiler Length (L <sub>G</sub> )	44 1/4"	50 1/2"	56 3/4"	63 1/4"	69 1/2"
Boiler Block Length (L <sub>K</sub> )	38 1/4"	44 1/2"	50 3/4"	57"	63 1/2"
Boiler Door Thickness	5"	5"	5"	5"	5"
Minimum Boiler Width (BE)	28"	28"	28"	28"	28"
Height	40 3/4"	40 3/4"	40 3/4"	40 3/4"	40 3/4"
Fire Box Depth (LF)	31"	37 1/2"	43 3/4"	50"	56 1/4"
Fire Box Diameter	15 3/4"	15 3/4"	15 3/4"	15 3/4"	15 3/4"
Fire Box Volume (cu. ft.)	5.19	6.39	7.59	8.79	9.99
Dry Weight (lbs)	1,197	1,391	1,585	1,779	1,973
Water Content (gal)	37.8	45.2	52.6	60	67.4
Operating Weight (lbs)	1,512	1,768	2,024	2,280	2,545

## G315 Foundation Dimensions

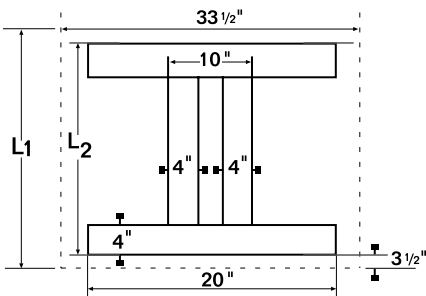

Boiler Model	315/5	315/6	315/7	315/8	315/9
Foundation Length L1	36"	42 1/4"	48 1/2"	54 1/4"	61"
Flat Plate Length L2	28 3/4"	35"	41 1/4"	47 1/2"	54"

The boiler must be placed on a smooth, level concrete base, 33 1/2" wide. Cement in the base or place on its top either 4" x 1/4" flat steel plates or 4" x 2" x 1/4" angle irons for boiler support. Dimensions L1 and L2 are specified in the table above.

315 Section Weights in lbs		
Front	Intermediate	Rear
199	199	191

Approval Numbers
MEA 356-98-E
CRN No# 616.TC



Buderus recommends the use of Beckett, Gordon Piatt, Power Flame and Riello burners for oil/gas firing (Buderus stocks Riello and Beckett burners).

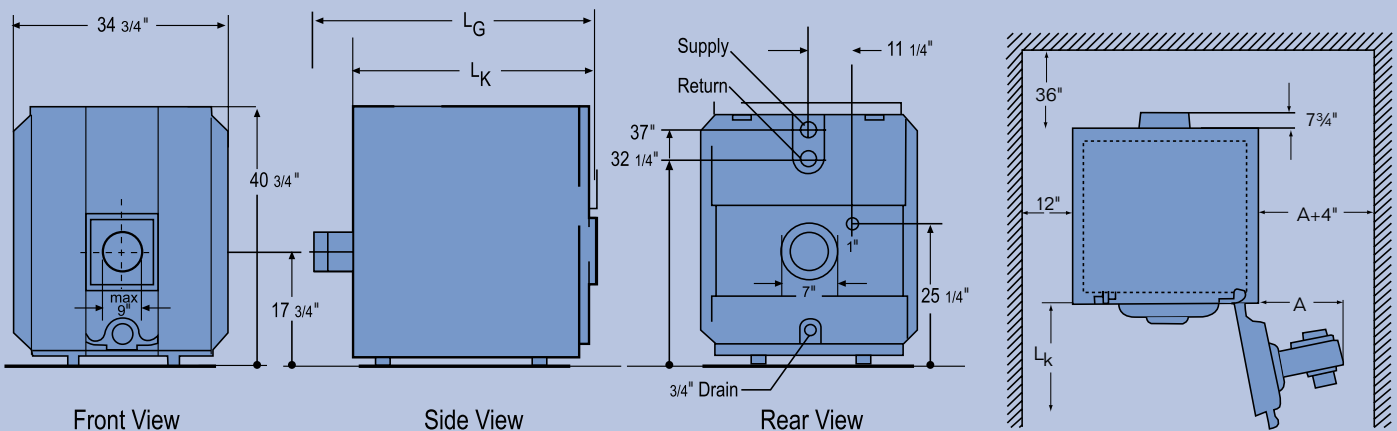

# G515

Model	G515/7	G515/8	G515/9	G515/10	G515/11	G515/12
<b>Performance Data</b>						
Gross Output MBH	818	1,009	1,200	1,391	1,582	1,773
# of Sections	7	8	9	10	11	12
Max Input Gas MBH	995	1,216	1,438	1,660	1,881	2,103
Max Input Oil GPH	6.9	8.4	10	11.6	13	14.6
Net IBR MBH	711	877	1,043	1,210	1,376	1,542
Boiler HP	24.5	30.2	35.9	41.6	47.3	53
Max Operating Pressure (psi)	87	87	87	87	87	87
Combustion Efficiency Oil	88.2%	88.2%	88.1%	88.1%	88.1%	88.1%
Combustion Efficiency Gas	85.6%	85.5%	85.5%	85.5%	85.4%	85.4%
<b>Piping Connections</b>						
Vent Connection Size	10"	10"	10"	10"	10"	10"
Supply	4"	4"	4"	4"	4"	4"
Return	4"	4"	4"	4"	4"	4"
<b>Physical Dimensions</b>						
Overall Boiler Length (L <sub>G</sub> )	62 <sup>1</sup> / <sub>4</sub> "	69	75 <sup>3</sup> / <sub>4</sub> "	82 <sup>1</sup> / <sub>2</sub> "	89 <sup>1</sup> / <sub>4</sub> "	95 <sup>3</sup> / <sub>4</sub> "
Boiler Block Length (L <sub>K</sub> )	54 <sup>1</sup> / <sub>2</sub> "	61	67 <sup>1</sup> / <sub>2</sub> "	74 <sup>1</sup> / <sub>4</sub> "	81"	87 <sup>1</sup> / <sub>2</sub> "
Boiler Door Thickness	5"	5"	5"	5"	5"	5"
Minimum Boiler Width (BE)	33"	33"	33"	33"	33"	33"
Height	52 <sup>1</sup> / <sub>4</sub> "	52 <sup>1</sup> / <sub>4</sub> "	52 <sup>1</sup> / <sub>4</sub> "	52 <sup>1</sup> / <sub>4</sub> "	52 <sup>1</sup> / <sub>4</sub> "	52 <sup>1</sup> / <sub>4</sub> "
Fire Box Depth (LF)	45 <sup>3</sup> / <sub>4</sub> "	52 <sup>1</sup> / <sub>2</sub> "	59 <sup>1</sup> / <sub>4</sub> "	66"	72 <sup>1</sup> / <sub>2</sub> "	79 <sup>1</sup> / <sub>4</sub> "
Fire Box Diameter	20 <sup>1</sup> / <sub>4</sub> "	20 <sup>1</sup> / <sub>4</sub> "	20 <sup>1</sup> / <sub>4</sub> "	20 <sup>1</sup> / <sub>4</sub> "	20 <sup>1</sup> / <sub>4</sub> "	20 <sup>1</sup> / <sub>4</sub> "
Fire Box Volume (cu. ft.)	14.87	17.16	19.46	21.75	24.05	26.31
Dry Weight (lbs)	2,731	3,059	3,505	3,864	4,188	4,541
Water Content (gal)	68.2	77.7	87.2	96.7	106.2	115.7
Operating Weight (lbs)	3,300	3,707	4,233	4,671	5,074	5,506

## G515 Foundation Dimensions

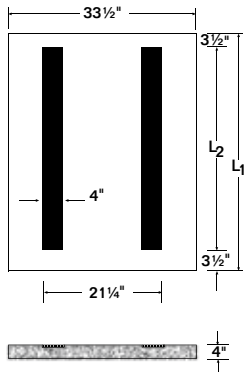

Boiler Model	515/7	515/8	515/9	515/10	515/11	515/12
Foundation Length L1	53 <sup>1</sup> / <sub>2</sub> "	60 <sup>1</sup> / <sub>4</sub> "	67"	73 <sup>1</sup> / <sub>2</sub> "	80 <sup>1</sup> / <sub>4</sub> "	87"
Flat Plate Length L2	46 <sup>3</sup> / <sub>4</sub> "	53 <sup>1</sup> / <sub>2</sub> "	60 <sup>1</sup> / <sub>4</sub> "	67"	73 <sup>1</sup> / <sub>2</sub> "	80 <sup>1</sup> / <sub>4</sub> "

515 Section Weights in lbs		
Front	Intermediate	Rear
326	331	357

Approval Numbers
MEA 293-97-E
CRN No# 1530.9C



Buderus recommends the use of Beckett, Gordon Piatt, Power Flame and Riello burners for oil/gas firing (Buderus stocks Riello and Beckett burners).

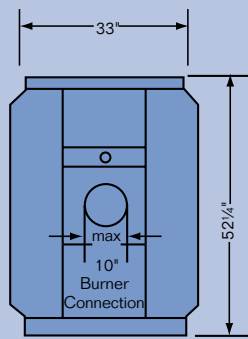

Front View

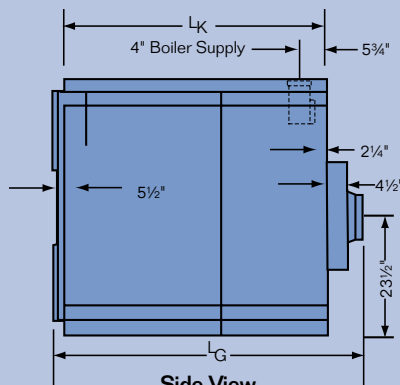

Side View

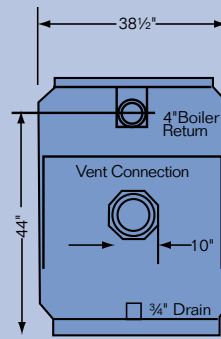

Rear View

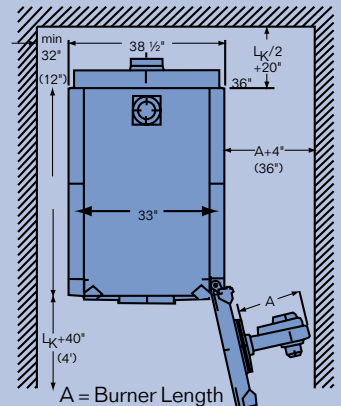

A = Burner Length

# G615

Model	G615/9	G615/10	G615/11	G615/12	G615/13	G615/14	G615/15	G615/16
<b>Performance Data</b>								
Gross Output MBH	1,951	2,242	2,532	2,822	3,112	3,402	3,692	3,982
# of Sections	9	10	11	12	13	14	15	16
Max Input Gas MBH	2,309	2,670	3,031	3392	3,753	4,113	4,474	4,835
Max Input Oil GPH	16	18.5	21	23.5	26	28.5	31	33.5
Net IBR MBH	1,697	1,950	2,202	2,454	2,706	2,958	3,210	3,463
Boiler HP	58.3	66.9	75.6	84.3	92.9	101.6	110.3	118.9
Max Operating Pressure (psi)	87	87	87	87	87	87	87	87
Combustion Efficiency Oil	86.7%	86.7%	86.6%	86.5%	86.5%	86.5%	86.5%	86.5%
Combustion Efficiency Gas	84.1%	84.1%	84%	84%	83.9	83.9%	83.9%	83.9%
<b>Piping Connections</b>								
Vent Connection Size	14"	14"	14"	14"	14"	14"	14"	14"
Supply	6"	6"	6"	6"	6"	6"	6"	6"
Return	6"	6"	6"	6"	6"	6"	6"	6"
<b>Physical Dimensions</b>								
Overall Boiler Length (L <sub>G</sub> )	75¾"	82½"	89¼"	96"	102½"	109¼"	116"	122¾"
Boiler Block Length (L <sub>K</sub> )	71"	77¾"	84½"	91"	97¾"	104½"	111¼"	117¾"
Boiler Door Thickness	5"	5"	5"	5"	5"	5"	5"	5"
Minimum Boiler Width (BE)	50½"	50½"	50½"	50½"	50½"	50½"	50½"	50½"
Height	62¾"	62¾"	62¾"	62¾"	62¾"	62¾"	62¾"	62¾"
Fire Box Depth (LF)	60"	66¾"	73½"	80"	86¾"	93½"	100¼"	106¾"
Fire Box Diameter	26¾"	26¾"	26¾"	26¾"	26¾"	26¾"	26¾"	26¾"
Fire Box Volume (cu. ft.)	23.56	26.21	29.07	31.46	34.08	36.72	39.34	41.97
Dry Weight (lbs)	5,510	6,045	6,580	7,110	7,645	8,160	8,799	9,125
Water Content (gal)	144	160	176	192	208	224	240	256
Operating Weight (lbs)	6,740	7,390	8,050	8,720	9,390	10,040	10,720	11,280

## G615 Foundation Dimensions

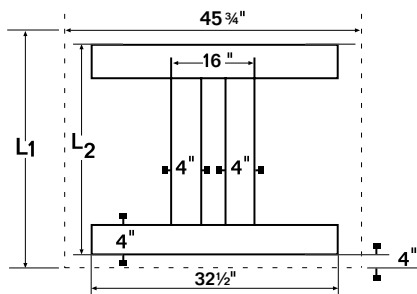

Boiler Model	615/9	615/10	615/11	615/12	615/13	615/14	615/15	615/15
Foundation Length L <sub>1</sub>	65¾"	72½"	79¼"	86"	92¾"	99¼"	106"	112½"
Flat Plate Length L <sub>2</sub>	58"	64½"	71¼"	78"	84½"	91¼"	98"	104¾"

615 Section Weights in lbs		
Front	Intermediate	Rear
565	545	657

Approval Numbers
MEA 67-01-E
CRN No# 1529.9C



Buderus recommends the use of Beckett, Gordon Piatt, Power Flame and Riello burners for oil/gas firing (Buderus stocks Riello and Beckett burners).

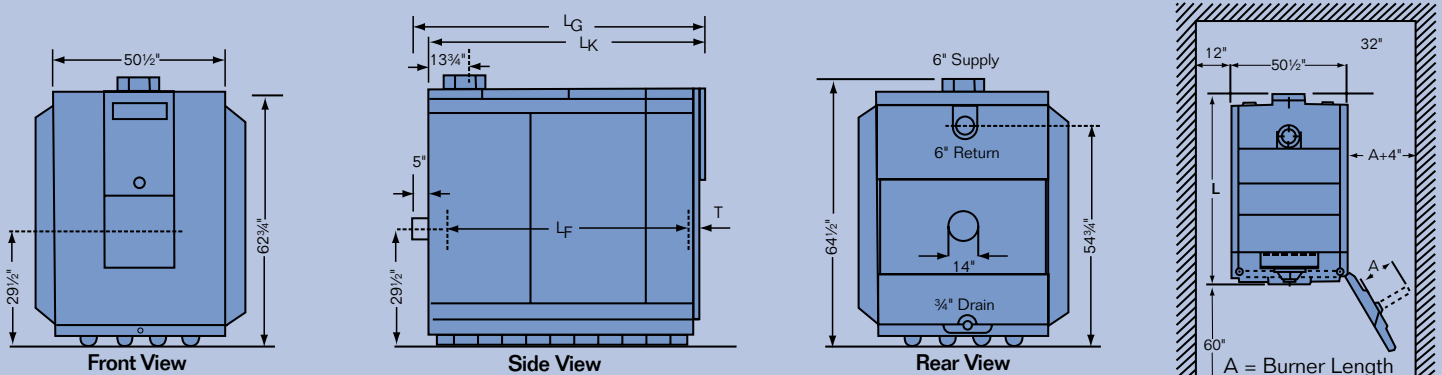

# G315 | G515 | G615

## Cast Iron Commercial Boilers

### A Tradition of Excellence

Buderus has been working with cast iron since 1731. In fact, Buderus produced the world's first low-temperature hydronic heating systems. Today, Buderus products are acknowledged as the world standard in high-efficiency, low emissions hydronic heating. All Buderus products are designed to meet strict safety and environmental regulations.

Buderus boilers are quickly and easily installed, will outlast and outperform virtually any other commercial hot water heating system, and are designed for easy access and service for maintaining the highest possible efficiencies throughout the lifespan of operation.

### Commercial Boiler Specifications:

- 1) There shall be provided and installed a quantity of \_\_ G315, G515 or G615 Buderus sectional cast iron hot water boiler(s) with a total gross output rating of \_\_MBH, suitable for forced draft firing with No. 2 fuel oil, natural gas, or propane. Maximum operating pressure of the boiler(s) shall be 87 psi. They shall bear the ASME stamp and IBR rating.
- 2) Boiler(s) shall be fabricated with GL-180M high silicone cast iron. They shall be of wet base, double wall, sectional construction with precision machined steel push nipples. Boiler(s) shall have a 5 year warranty against defects in the heat exchanger.
- 3) Boiler(s) shall be of full three pass design, capable of achieving combustion efficiencies up to 88% on oil and up to 85.6% on gas at full firing rate. Boiler(s) shall contain no refractory material or combustion target wall.
- 4) Boiler(s) shall be capable of sustained operation at any return water temperature without any means external to the boiler to temper or preheat return water. When operating with standard high temperature controls a water temperature of 122° F must be reached within ten minutes at the boiler supply during burner operation.
- 5) Access to boiler firesides for inspection and service shall be through a fully insulation and jacketed door, field adjustable for left or right hinging. The seal between door and boiler casing shall be a permanent dry gasket for repeated positive sealing. All flue passages shall be accessible only through the front door and removable rear clean-out covers.
- 6) Boiler(s) shall be furnished with a heavy-gauge baked enamel jacket with a full 3 ½ or 4 insulation on top and on all sides, flanged water connections and a cast iron flue collector for long life.

### Operational Requirements for the G315, G515 and the G615

- Maintain minimum 122° F supply temperature with standard high temperature controls during burner operation within 10 minutes after burner starts up.
- No additional requirements for firing with 2-stage or full modulation burners (gas or oil).
- No minimum return water temperature and no minimum flow requirement.
- Boiler(s) shall nor require any means or return water temperature control or minimum flow condition.

### Superior Design

- Designed to operate at any return water temperature
- Full swing burner door for easy and quick, thorough cleaning.
- No refractory parts for reduced maintenance.
- Boiler fully serviced and cleaned from the front.
- Cast iron breaching for long life.
- Thermostream design increases efficiency and system reliability.
- High efficiency through full three pass boiler design.
- No thermal shock as result of unique Thermostream boiler design.
- No minimum water temperature.
- Savings in overall equipment costs, installations and annual operating costs.
- High combustion and thermal efficiencies.

#### Gross Outputs:

<b>G315</b>	350 - 768 MBTU/Hr
<b>G515</b>	818 - 1,773 MBTU/Hr
<b>G615</b>	1,951 - 3,982 MBTU/Hr

# Buderus

Bosch Thermotechnology Corp.  
50 Wentworth Ave  
Londonderry, NH 03053  
Tel: (603) 552-1100  
Fax: (603) 584-1681

Subject to change without notice  
© 2008 Bosch Thermotechnology Corp.  
Part Number 44499017 02/08