

Assembly, Maintenance and Operating Instructions

Buderus G615 Boiler

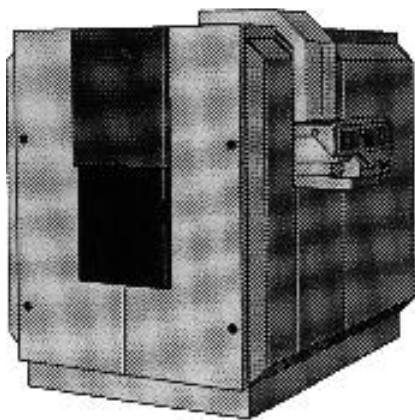

Logano G615

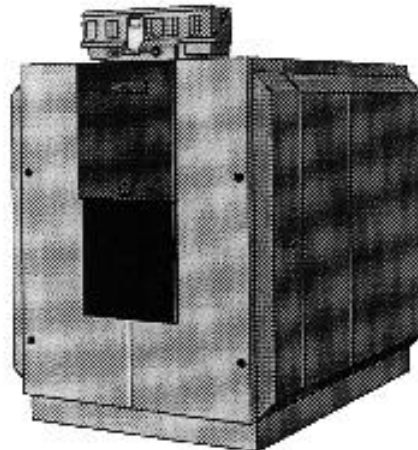

Logano G615











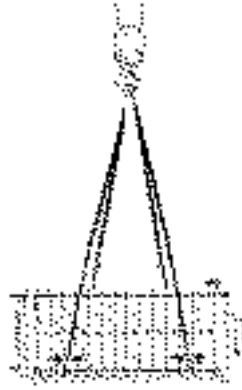



Save These Instructions!

This assembly, maintenance and operating manual must be kept near the boiler!

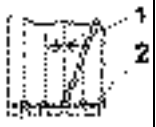
TABLE OF CONTENTS

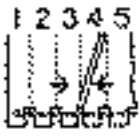
1	Boiler Transport Directions	3
2	General Guidelines	4
3	Boiler Operating and Technical Data	5-6
4	Boiler Foundation and Minimum Boiler Clearances	7
5	Assembly Tools/Tools Req'd for Boiler Assembly	8
6	Boiler Assembly	9-16
7	Hydrostatic Test	17
8	Installation of Boiler Components	18-20
9	Installation of Insulation & Boiler Jacket Panels	21-26
10	Buderus Control Panel Installation	27
11	Maintenance Instructions	28-30
12	Supply Temperature Control	31
13	Shipping Components Breakdown	32



	G615 Weights and Technical Data										
	Gross Output	MBH	1,951	2,242	2,532	2,822	3,112	3,402	3,692	3,982	
	Number of Boiler Sections		9	10	11	12	13	14	15	16	
	Net Weight	Lbs.	5510	6045	6580	7110	7645	8160	8700	9125	
	Use 4 straps or cables with each a minimum capacity of 12,000 lbs. Stacking of boiler blocks is permissible provided the boiler is secured to a pallet.										
	When using multiple straps, one must assume that only two straps are supporting the weight.										
	Maximum permissible strap angle = 45°. Place straps at the bottom of the block always between tie bars and boiler block and between markings on the boiler block.										
	Strap Location for different boiler models										
	Gross Output	MBH	1,951	2,242	2,532	2,822	3,112	3,402	3,692	3,982	
	Number of Boiler Sections		9	10	11	12	13	14	15	16	
	Strap location between sections	(measured from front or back)	2-3					3-4			
	Remove transport blocking pieces from the top and bottom nipple ports only after boiler is put in final location.										
	A lifting crane must be operated by qualified personnel.										
	When transporting the boiler block by truck, make sure to strap the block down.										

2 General Guidelines

Installation, maintenance and service of this boiler must only be carried out by a qualified contractor. The assembly sequence is essential to reliable operation of the boiler and associated heating system. The boiler can be assembled, hydrostatically tested and operated without boiler insulation and jacket panels. These items can be installed at a later date without disrupting boiler operation.

All work shall be performed in strict accordance with the requirements of state and local regulating agencies and codes dealing with boiler installations. Initial start-up must be performed by qualified personnel. After start-up the owner or its representative should be instructed about the boiler operation and be given the assembly and maintenance manual.

Boiler cleaning and maintenance must be carried out once annually. This includes an overall check of the heating system. Any discrepancies must be corrected immediately.

NOTE: To perform the hydrostatic pressure test after the boiler is assembled, several, 3/4" plugs 6" blanking flanges and a 3/4" air vent are needed. These items are *not* furnished with the boiler.

NOTE: This manual is for reference only. The manual does NOT purport to address all design, installation and safety considerations. It is the responsibility of the user of this manual to determine the applicability and safety of each individual application and ensure its compliance with local building codes.

It is expected that the user/installer is a licensed heating contractor with knowledge of accepted industry practices for the installation and maintenance of the equipment and various applications of the equipment involved.

G615 Component breakdown

The G615 boiler can be delivered as an assembled block or in knockdown version. Verify that you received the components listed below. Refer to Section 13 for item-by-item description.

Follow the boiler block handling instructions on the inside cover of this manual in case of an assembled boiler block.

Unassembled Boiler

1	Pallet	Front, rear, mid-section with supply connection and burner door.
2-5	Pallets	Required number of mid-sections
1	Box	Base unit: common boiler accessories
1	Box	Model specific assembly parts
1	Box	Jacket assembly parts
1	Box	Jacket panel "A"
1	Box	Jacket panel "B"
1	Plastic bag	Insulation blanket
1	Bundle	Model specific tie bars with spring assemblies
1	Box	Supply manifold, 6" return header
1	Box	Stack damper (optional)

Assembled Boiler

1	Pallet	Assembled boiler block
1	Box	Base unit: common boiler accessories
1	Box	Jacket assembly parts
1	Box	Jacket panel "A"
1	Box	Jacket panel "B"
1	Plastic bag	Insulation blanket
1	Box	Supply manifold, 6" return header
1	Box	Stack damper (optional)

Boiler operating ratings

Maximum supply temperature: 248°F (120°C)
 Maximum operating pressure: 80 psi

Operational requirements for G615 boilers

Type of control	Min. boiler flow	Min. return water temperature †	Interrupted boiler operation	Min. supply temp. during burner operation ‡
Standard high limits	No requirement	None	No requirement	122°F (oil firing) 140°F (gas firing)
Logamatic: reset	No requirement	None	No requirement	122°F (oil/gas firing)

† In normal heating applications, the G615 boiler does not require a minimum return water temperature. In snow melt applications with ice water return temperatures, a minimum supply temperature of 160°F must be maintained.

‡ The listed supply temperature must be reached within 10 minutes after burner start-up and maintained to ensure condensate free operation.

Water quality requirements

Fill water requirement: water with alkalinity < 200 mg/li for initial system filling.

Make-up water requirement: water with alkalinity < 30 mg/li

System water requirements:

pH value (@ 77°F): 9.0 - 10.0
 Acid capacity: 3.0 - 50 mg/li
 Oxygen (O₂): .01%
 Phosphate (P₂O₅): 2.5 %
 Sodium sulfate (Na₂SO₃): 1 - 4%

For overall system protection, it is recommended to install a filter and sludge removal system in the boiler return piping.

Any approved (based on application testing at burner manufacturer's facilities) oil, gas or dual fuel burner can fire into G615 boilers. Burners with low fire start or two stage firing are recommended. The high fire setting on the burner should match the rated output of the boiler to prevent condensation in the heat exchanger. The CO volume percent in undiluted, dry flue gas should not exceed .01% (100 ppm).

3 Boiler Operating & Technical Data

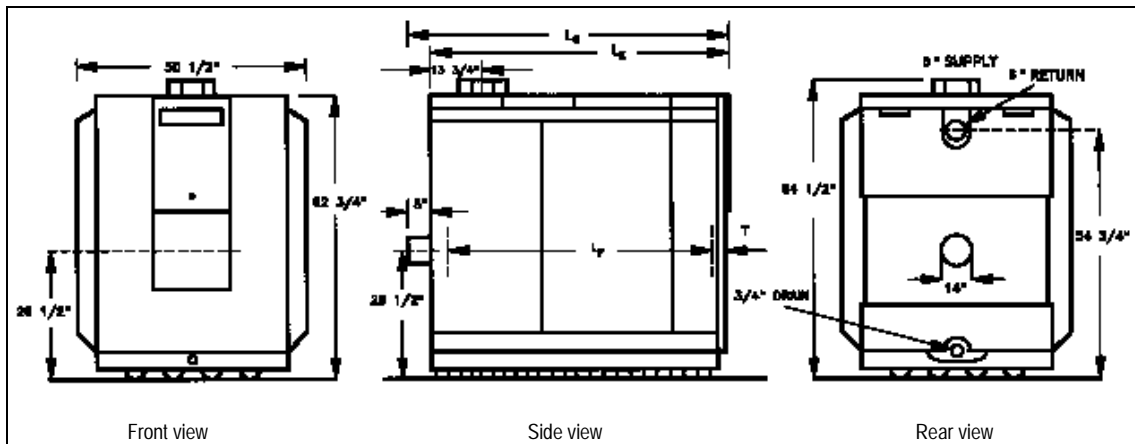

Fig. 1: Schematic Drawings

Table 1: Boiler Dimensions

Boiler Model	615/9	615/10	615/11	615/12	615/13	615/14	615/15	615/16
Gross Output, MBH	1951	2242	2532	2822	3112	3402	3692	3982
Number of Sections	9	10	11	12	13	14	15	16
Overall Boiler Length, Inches L_G	75 $\frac{3}{4}$	82 $\frac{1}{2}$	89 $\frac{1}{4}$	96	102 $\frac{1}{2}$	109 $\frac{1}{4}$	116	122 $\frac{3}{4}$
Boiler Block Length, Inches L_K	71	77 $\frac{3}{4}$	84 $\frac{1}{2}$	91	97 $\frac{3}{4}$	104 $\frac{1}{2}$	111 $\frac{1}{4}$	117 $\frac{3}{4}$
Fire Box Depth, Inches L_F	60	66 $\frac{3}{4}$	73 $\frac{1}{2}$	80	86 $\frac{3}{4}$	93 $\frac{1}{2}$	100 $\frac{1}{4}$	106 $\frac{3}{4}$
Fire Box Diameter, Inches	26 $\frac{3}{4}$	26 $\frac{3}{4}$	26 $\frac{3}{4}$	26 $\frac{3}{4}$	26 $\frac{3}{4}$	26 $\frac{3}{4}$	26 $\frac{3}{4}$	26 $\frac{3}{4}$
Total Gas Volume, cu. ft.	23.56	26.21	29.07	31.46	34.08	36.72	39.34	41.97
Dry Weight, Lbs.	5510	6045	6580	7110	7645	8160	8700	9125
Water Content, Gal.	144	160	176	192	208	224	240	256
Operating Weight, Lbs.	6740	7390	8050	8720	9390	10040	10720	11280
Vent Connection Size, Inches	14	14	14	14	14	14	14	14
Door Thickness, Inches	5 $\frac{3}{8}$	5 $\frac{3}{8}$	5 $\frac{3}{8}$	5 $\frac{3}{8}$	5 $\frac{3}{8}$	5 $\frac{3}{8}$	5 $\frac{3}{8}$	5 $\frac{3}{8}$
Width, Inches	50 $\frac{1}{2}$	50 $\frac{1}{2}$	50 $\frac{1}{2}$	50 $\frac{1}{2}$	50 $\frac{1}{2}$	50 $\frac{1}{2}$	50 $\frac{1}{2}$	50 $\frac{1}{2}$
Height, Inches	62 $\frac{3}{4}$	62 $\frac{3}{4}$	62 $\frac{3}{4}$	62 $\frac{3}{4}$	62 $\frac{3}{4}$	62 $\frac{3}{4}$	62 $\frac{3}{4}$	62 $\frac{3}{4}$

Table 2: Technical Specifications

Boiler Model	615/9	615/10	615/11	615/12	615/13	615/14	615/15	615/16
Gross Output, MBH	1951	2242	2532	2822	3112	3402	3692	3982
Number of Sections	9	10	11	12	13	14	15	16
Boiler HP	58.3	66.9	75.6	84.3	92.9	101.6	110.3	118.9
NETIBR Rating, MBH	1697	1950	2202	2454	2706	2958	3210	3463
Oil Firing Rate, GPH	16.0	18.5	21.0	23.5	26.0	28.5	31.0	33.5
Max Gas Input, MBH	2309	2670	3031	3392	3753	4113	4474	4835
Fire Side Heating surface, sq. ft.	253.50	284.28	314.95	345.72	376.49	407.16	437.93	468.60
Combustion Efficiency Oil, %	86.7	86.7	86.6	86.6	86.5	86.5	86.5	86.5
Combustion Efficiency Gas, %	84.1	84.1	84.0	84.0	83.9	83.9	83.9	83.9
Overfire Press I.W.C.	.8	.85	1.2	1.63	1.15	1.3	1.4	1.5
Fireside Press. Drop, In. W.C.	1.09	1.49	1.93	1.85	1.85	1.93	2.09	2.33
Waterside Press. Drop, Ft. of Head	3.8	3.1	3.3	3.2	3.4	3.1	3.0	3.5

Boiler Foundation and Minimum Boiler Clearances 4

Boiler foundation preparations

It is required that the boiler is placed on a level, smooth concrete base, of sufficient strength. The width of the platform must be 45 3/4". Length L1 is the platform length. It is required to cement in either a 4" x 1/4" flat steel plate or a 4" x 2" x 1/4" angle iron, as shown in Figure 2; Table 3 shows dimensions.

NOTE: Use suitable equipment and great care when moving the cast iron sections to the boiler room.

Table 3: Foundation Dimensions and Steel Strip Lengths.

Boiler Model	Foundation Length L1	Strip Spacing L2	Steel Strip Length L3
G615/9	65 3/4"	58"	50"
G615/10	72 1/2"	64 1/2"	56 3/4"
G615/11	79 1/4"	71 1/4"	63 1/2"
G615/12	86"	78"	70"
G615/13	92 1/2"	84 1/2"	76 3/4"
G615/14	99 1/4"	91 1/4"	83 1/2"
G615/15	106"	98"	90"
G615/16	112 1/2"	104 3/4"	96 3/4"

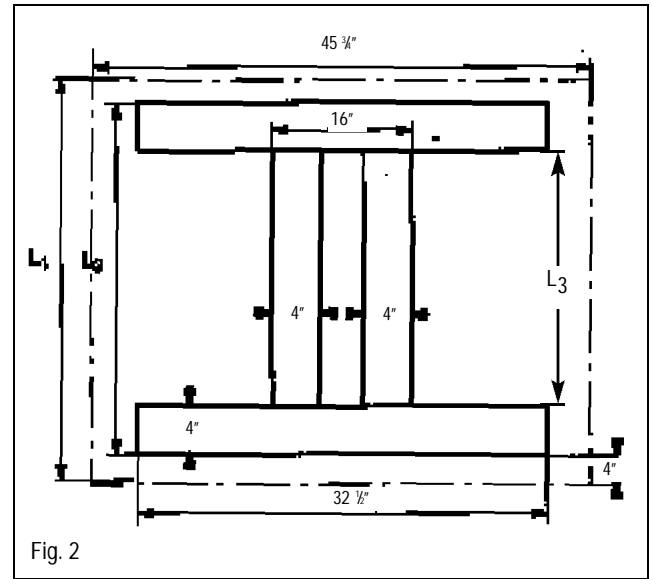

Recommended and Absolute Minimum Clearances

Recommended wall clearances for easy opening of burner door, ample access for boiler assembly and maintenance are listed below, as well as absolute minimum clearances. **Numbers in brackets list the absolute minimum clearances required.** (see Fig. 3 for details).

Model	Side Clearance	β Clearance †	(A)Front Clearance	Rear Clearance
G615/9	16" (12")	A + 4" (12")	90" (55")	45" (32")
G615/10	16" (12")	A + 4" (12")	90" (55")	45" (32")
G615/11	16" (12")	A + 4" (12")	90" (55")	45" (32")
G615/12	16" (12")	A + 4" (12")	90" (55")	45" (32")
G615/13	16" (12")	A + 4" (12")	120" (60")	45" (32")
G615/14	16" (12")	A + 4" (12")	120" (60")	45" (32")
G615/15	16" (12")	A + 4" (12")	120" (60")	45" (32")
G615/16	16" (12")	A + 4" (12")	120" (60")	45" (32")

AB: Burner Length (In).

† Minimum clearance of 12" requires removal of burner prior to swinging burner door open.

Note: The use of segmented cleaning brushes is required in case of the minimum listed front clearance.

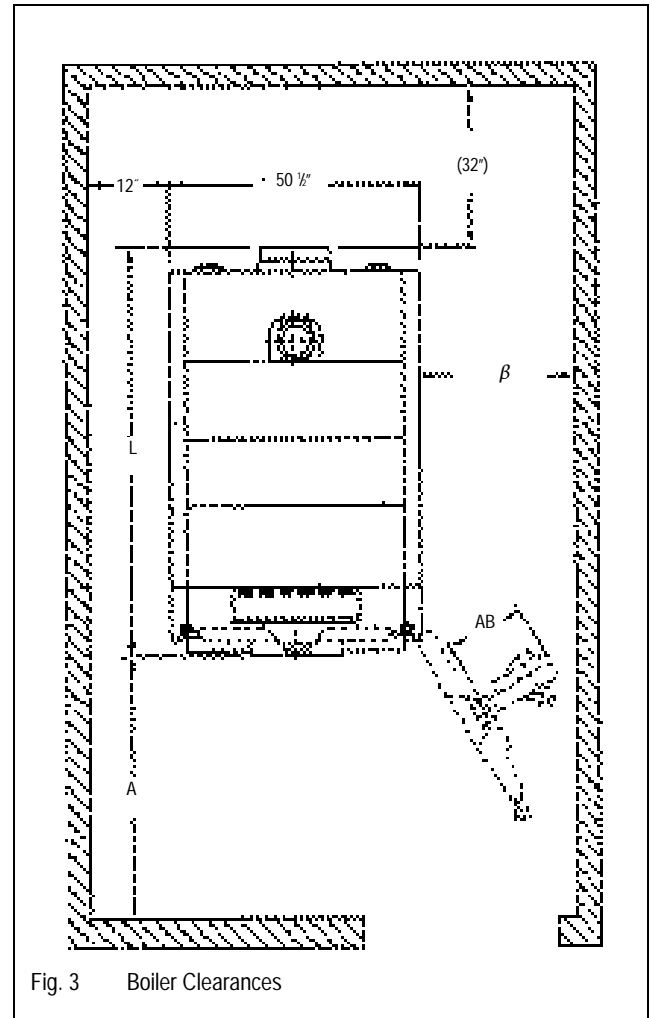

5 Assembly Tools/Tools Req'd for Boiler Assembly

Assembly tools and auxiliary assembly materials

- ✓ Boiler assembly tool set 2.2 (Fig. 4) or 2.3 (Fig. 5)
- ✓ Wooden or rubber mallet
- ✓ Half-round rough file
- ✓ Flat head and Phillips screwdrivers
- ✓ Flat chisel, steel strips for boiler support
- ✓ Metric wrenches sizes 13, 19, 24, 36 and socket size 19 (US equivalent sizes may also be used)
- ✓ Cleaning rags, machine oil, paint thinner, level, steel wire brush, tape measure, chalk.

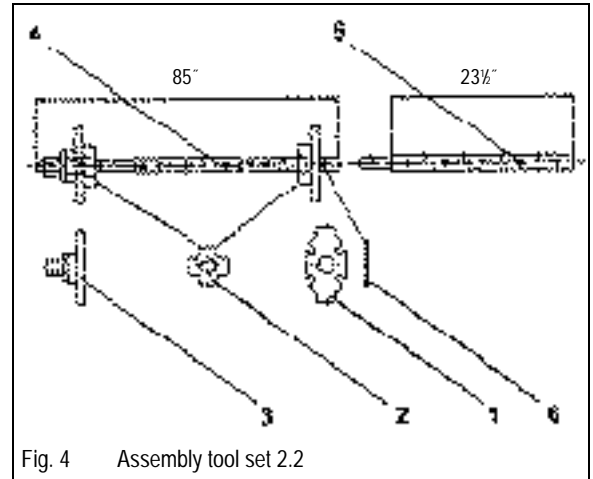

Fig. 4 Assembly tool set 2.2

Assembly Tool Set 2.2

Boiler Model	Assembly tools per nipple port	Extension pieces per nipple port	Total Length (in.)
G615/9-10	1	0	85
G615/11-14	1	1	109
G615/15-16	1	2	132

Assembly Tool Set 2.3 (packaged complete in toolbox).

Boiler Model	Assembly tools per nipple port	Extension pieces per nipple port	Total Length (in.)
G615/9-16	1	3	121

Legend for Figs. 4 and 5

- 1 - Stop flange
- 2 - Small pressure flanges
- 3 - Pressure bearing flange
- 4 - Assembly rod
- 5 - Extension piece
- 6 - Locking pin (tool set 2.2)
- 7 - Locking wedge (tool set 2.3)

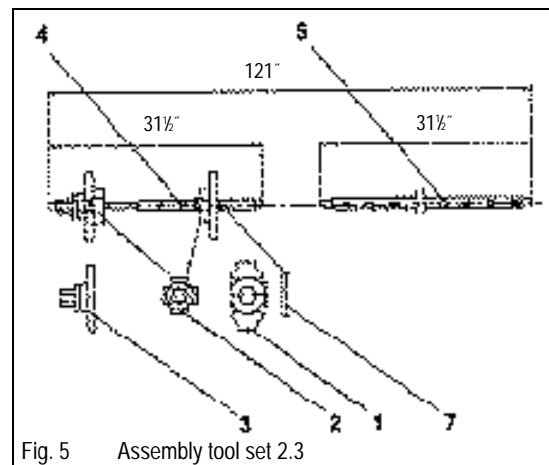

Fig. 5 Assembly tool set 2.3

6 Boiler Assembly

Assembled boiler block installation

The assembled block has been hydro-statically tested at the factory. Follow foundation detail and boiler clearances instructions on page 7. Then go to page 15 for the installation of insulation and boiler jacket panels.

Unassembled boiler installation

The boiler assembly always proceeds from the rear to the front; beginning with the rear section. The front section is always installed last. The mid-section with the supply connection is always installed directly following the rear section. Arrows located on the side of each section must always point towards the rear of the boiler as shown in Figure 6.

Legend

- 1 - Boiler foundation
- 2 - Flue collector
- 3 - Rear section
- 4 - Mid section with supply connection
- 5 - Mid sections
- 6 - tie bar (4 total)
- 7 - Arrow
- 8 - Front section
- 9 - Burner door with burner mounting plate

Assembly of individual boiler sections

- Remove the nuts and washers from the rear and front sections prior to boiler assembly.
- Note the arrow marking on each section. These arrows are located on the top left and right of each section and must point to the rear during boiler assembly (Fig. 6).
- Assemble the boiler on a smooth hard surface with flat steel plates underneath to permit easy sliding of sections.
- Position and align the rear section upright in final location and secure it from falling over (Fig. 7).
- To reduce the risk of injuries, support the boiler section or secure it with an overhead lifting device.

Buderus Hydronic Systems can supply at a rental fee the G615 support bracket set as shown in Fig. 7.

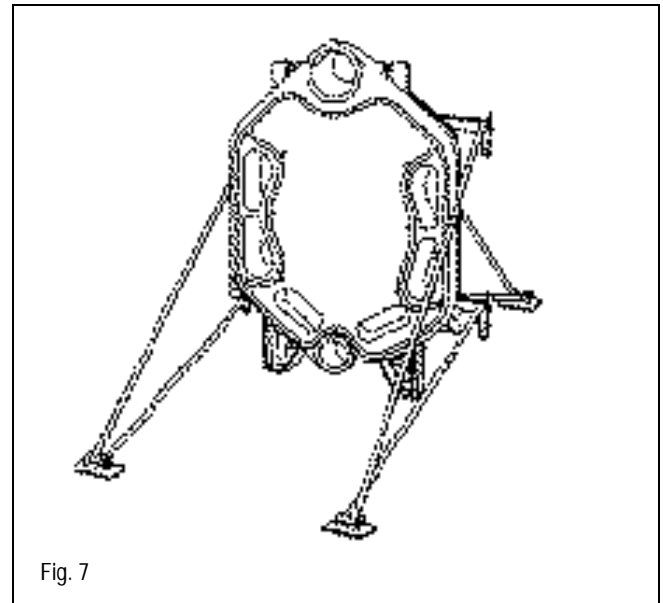
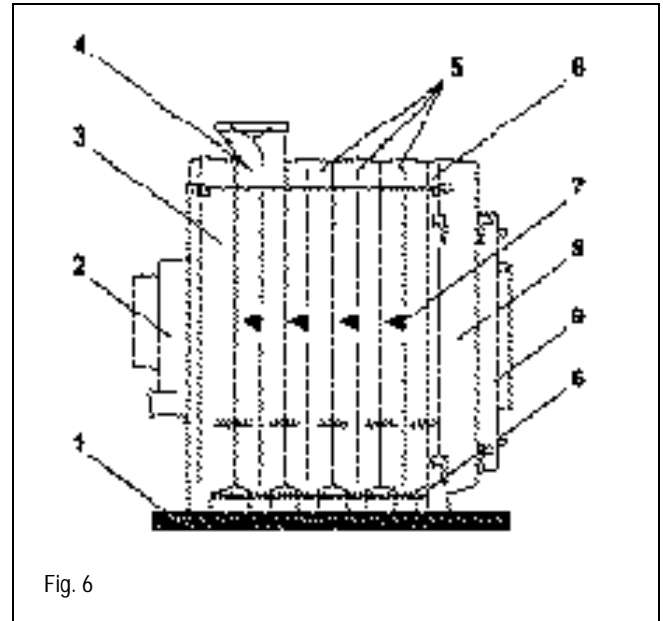

6 Boiler Assembly

CAUTION: The work area must be well ventilated during boiler assembly.

WARNING: Keep Buderus Haftgrund 181 primer away from flame! Do not smoke during assembly! *Do not* pour Buderus Haftgrund 181 primer down open drains!

- File off any burrs from the nipple ports (Fig. 8).
- Clean the sealing surfaces of the nipple ports with a rag soaked in thinner or gasoline. Wipe dry (Fig. 9: 1,2).
- Evenly coat the nipple port sealing surfaces with the orange sealing compound (Leinolmennige) using the brush provided (Fig. 9).
- Clean a set of push nipples with a rag soaked in thinner. Wipe dry. A set consists of the 181/170 mm top nipple and the 119/50 mm bottom nipple.
- Evenly coat the outer surface of each push nipple with the orange sealing compound.
- Insert the coated side of the nipples into the ports.
- Set nipples in place by tapping evenly with a rubber or wooden mallet. Make sure the nipples remain perfectly aligned with the boiler section (Fig. 10).

NOTE: *If a burr on the push nipple occurred during nipple insertion, file it off immediately!*

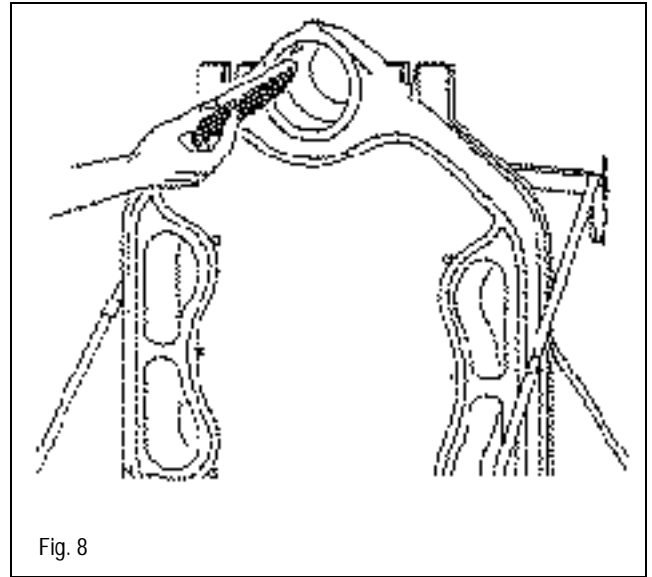

Fig. 8

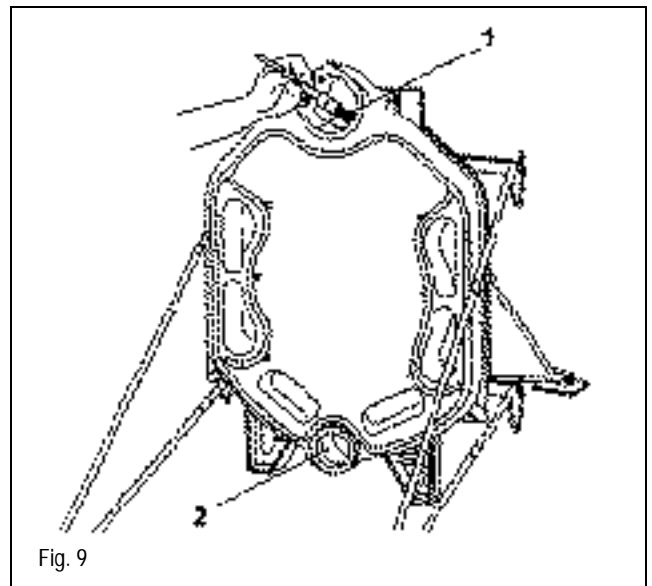

Fig. 9

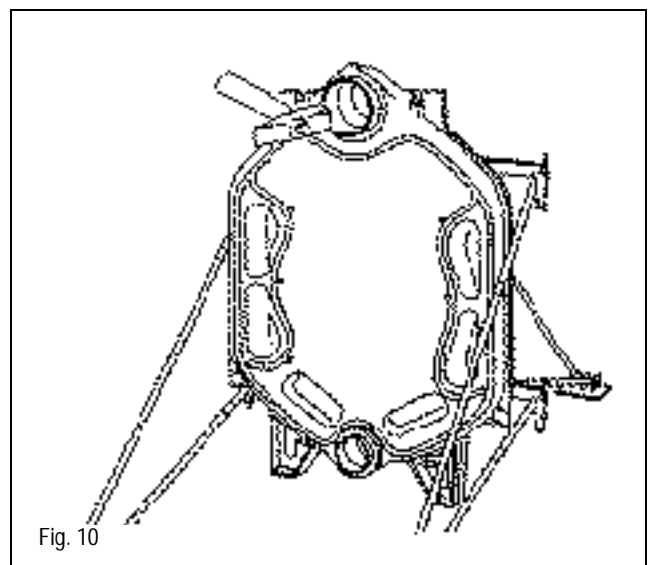
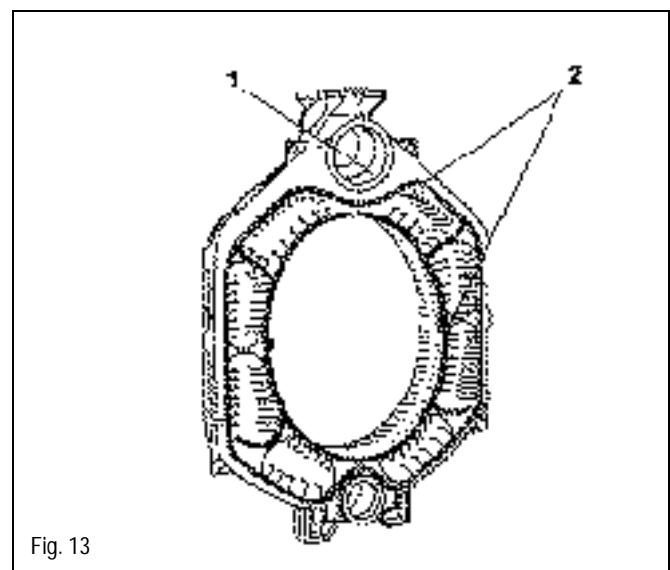
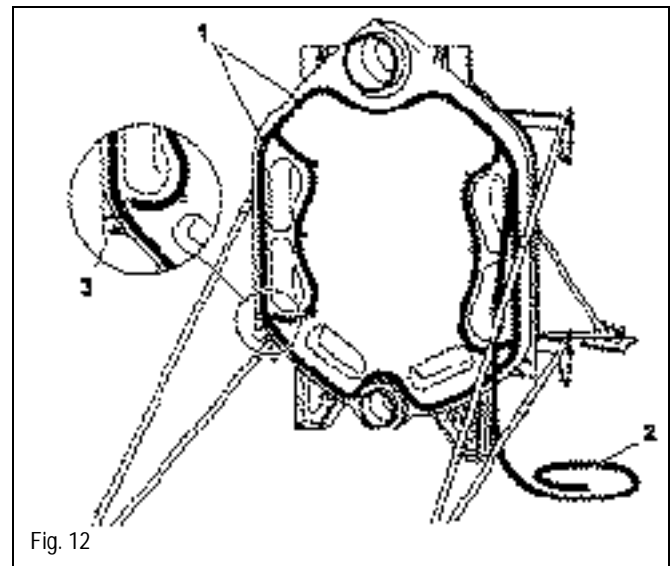
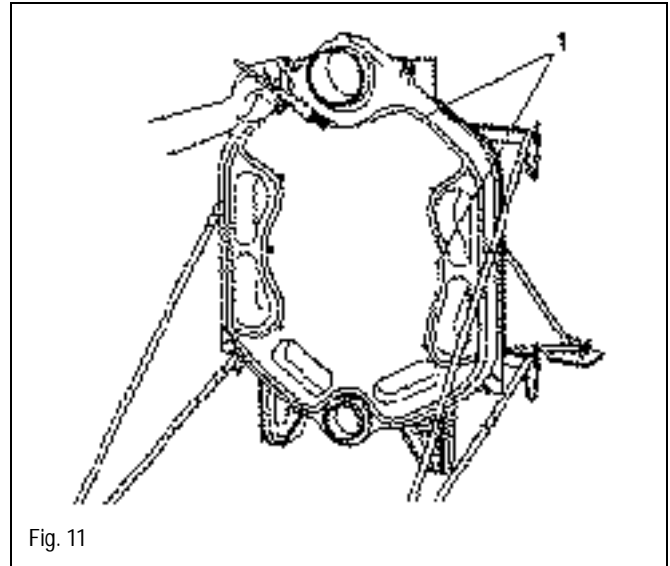

Fig. 10

- Clean the sealing grooves for sealing the flue side of the boiler using a steel wire brush. Make sure surfaces are dry, clean and free of any oily residues.
- Apply the Buderus Haftgrund Primer 181 to all sealing grooves using a small paint brush (Fig. 11).
- The sealing of the flueway of each section is achieved with the sealing cord. The sealing cord can be installed 5 to 15 minutes after the application of the primer.
- Insert the elastic sealing cord (“Dichtschnur”) into the sealing groove only on the front side of the rear section. Start at the top (1) and press lightly to adhere to the Primer 181 (Fig. 12).
- Unroll sealing cord and remove paper backing during installation. Cut sealing cord to length with a pair of scissors or knife (2). Butt sealing cord ends tightly together or overlap cord ends 1” for proper sealing. Maintain a small gap at location (3), on both sides. Fig. 12.
- Now place the intermediate section with supply connection upright and secure from falling. Brace section or secure with an overhead chain and hook.
- File off any burrs from the nipple ports.
- Clean nipple ports with a rag soaked in cleaning agent (1). (Fig. 13).
- Coat the nipple ports with orange push nipple paint. (Fig.13)
- Lightly brush flue side grooves on rear side of mid-section with wire brush and clean with rags (2).



NOTE: The grooves must be clean and dry.

This completes the preparation of the joint between the rear section and the first intermediate section.

- Check:*
1. Both push nipples installed evenly with the rear section and nipples and ports fully coated with orange sealing compound.
 2. Sealing cord is properly installed in all sealing grooves.

- Position intermediate section in front of rear section and hang from upper push nipple. It may be necessary to lift up the intermediate section at the bottom with a bar. Arrow markings must point to the rear. (Fig. 14).
- After aligning ports with push nipples, tap against the intermediate section with the mallet to seat it on the push nipple. (Fig. 14).

6 Boiler Assembly

Pull sections together with boiler assembly tool

- Place assembly rods (1,2) through upper and lower ports (Fig. 15).
- Slide large spacer flanges (4) on tools and secure with locking pins (Tool set 2.2) or locking wedge (Tool set 2.3).
- Thread the pressure flanges (3) on the rods.
- Lock flanges on assembly rods by hand tightening assembly tools.
- Ensure that the tools are centered in the ports by having flanges properly located.
- Use socket wrenches provided to draw sections together evenly. Stop tightening when boiler sections butt metal to metal. Unscrew assembly tools. Oil pressure flange and tool threads on a regular basis.

NOTE: Inspect seating to ensure nipples are seated square. Never draw more than one section at a time to avoid damage to the push nipples and ports.

NOTE: Stop tightening once adjoining sections meet. Further tightening can damage the sections.

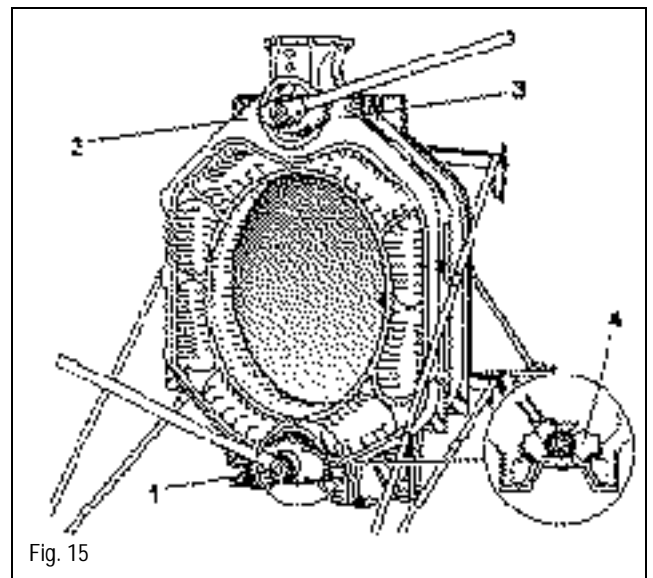
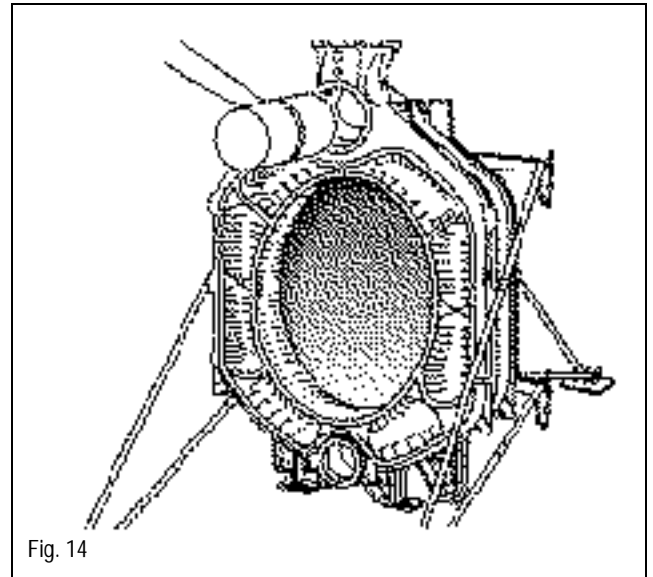

- Loosen and remove assembly tools.
- Verify proper seating of push nipples.

NOTE: When using the sectional assembly tool 2.3, verify that the assembly tool pieces always remain fully engaged, and tighten them as needed. If these pieces do not remain fully engaged, it will result damage to the assembly tool. (Fig. 16).

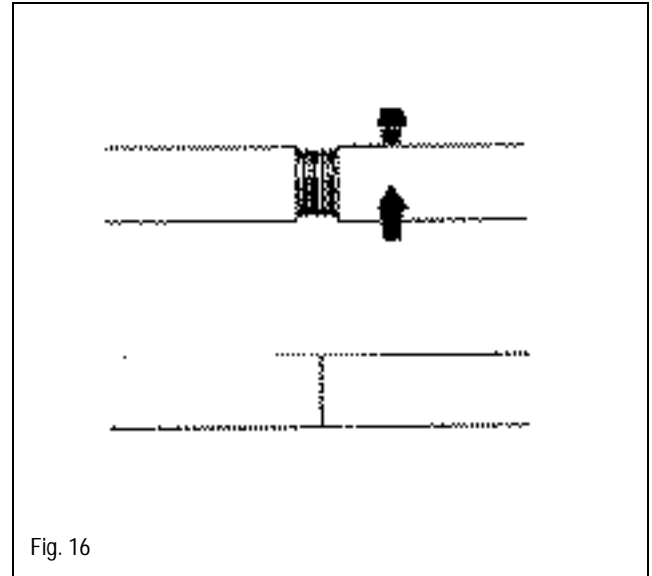

Fig. 16

Fig. 17 shows the intermediate section with supply connection. Prepare nipple ports and sealing grooves and install pushnipples and sealing cord. Again, leave a small opening between the sealing cords at location (1), Fig. 17.

Steel wedges (2) are supplied with each boiler for leveling after the boiler is fully assembled and put in its final place.

- Repeat boiler assembly procedure for subsequent sections as detailed on pages 9-11.

NOTE: After the boiler block has been drawn together, loosen the tools, but do not remove.

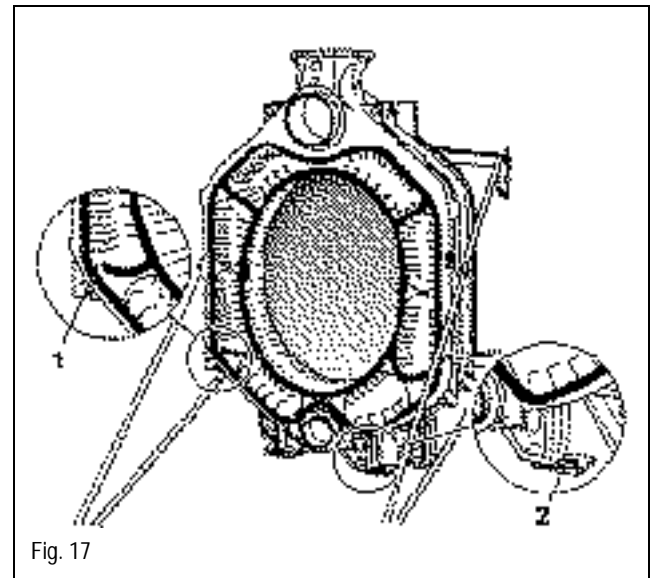

Fig. 17

- Install tie bars in the cast iron slots on the left and right sides of the (2) upper and lower (1) nipple ports (Fig. 18).
- Slide one spring assembly (3) on each tie bar at the rear section. Do not disassemble the spring assemblies! Place a washer and nut at both ends of each tie bar.
- Hand tighten each nut first; then tighten the tie bar nuts on one end by 1 to 1½ turns with a wrench.
- Level the boiler horizontally and vertically. Now, remove the assembly tools.

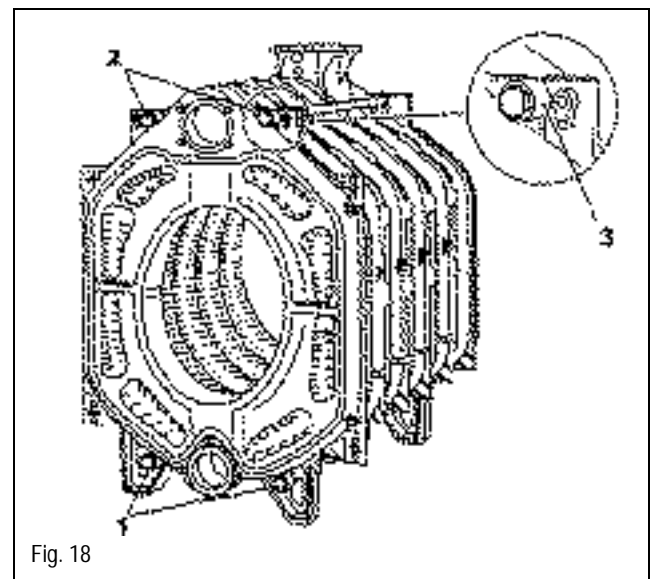

Fig. 18

6 Boiler Assembly

Final Placement of assembled block.

- Cut straps (1) and remove block from pallet. (2)(Fig. 19).
- Refer to G615 Transport Directions for details on moving an assembled G615 boiler block.
- Place boiler block on the foundation. Use the furnished wedges to level boiler and properly support each boiler leg.
- After final placement, remove the supplied transport hardware from the top and bottom nipple ports. (Fig. 20).

NOTE: The insulation of distribution header, flow blocking pipe, supply manifold and control wells must be done for both unassembled and assembled boiler blocks.

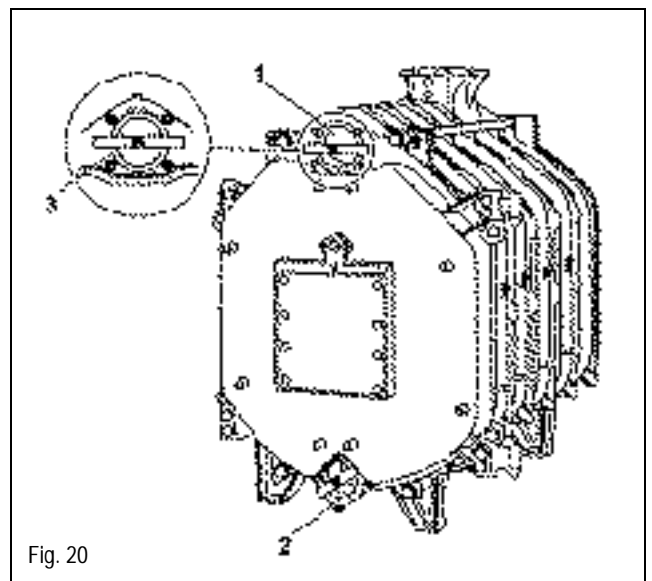
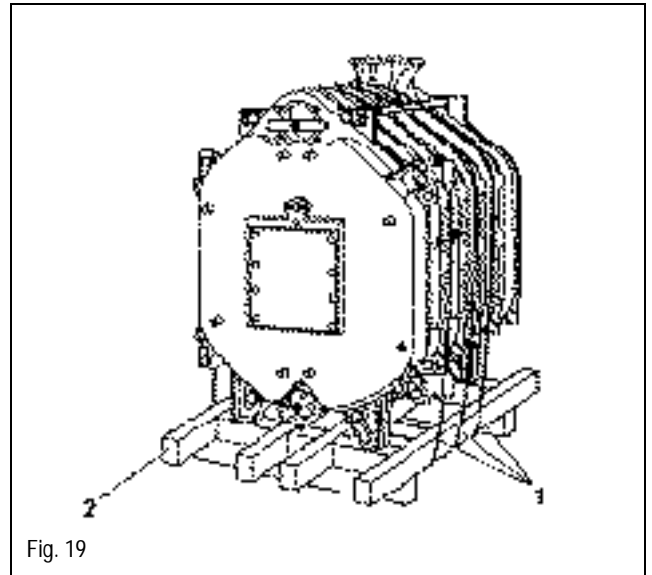

Return header pipe installation.

(Packaged with jacket assembly parts).

Top front connection: return header pipe.

- Slide gasket (1) over return header pipe (4) assembly (Fig. 21).
- Slide header pipe into top front connection (Fig. 21). (G615/9-11 requires 2 pieces, G615/12-16 3 pieces). Secure pieces to each other during insertion.

NOTE: Place tab (3) of header pipe into the provision (5) on the front section. This tab assures proper orientation of the header pipe internally.

- Slide blanking flange (2) on studs, install washers and nuts and tighten securely.
- Install gasket and 6" return header on return connection. Blank off.
- Blank off bottom rear connection with gasket and flange, install 3/4" boiler drain (Fig. 24)

Top supply connection = boiler supply.

- Place gasket and USA supply manifold on supply connection. Plug all ports using aquastat wells or plugs. Blank off 6" supply connection. (Blanking flange not supplied) (Fig. 23).
- Install 3/4" well in upper tapping, install 1/2" well in lower tapping in supply connection. (Fig. 22).

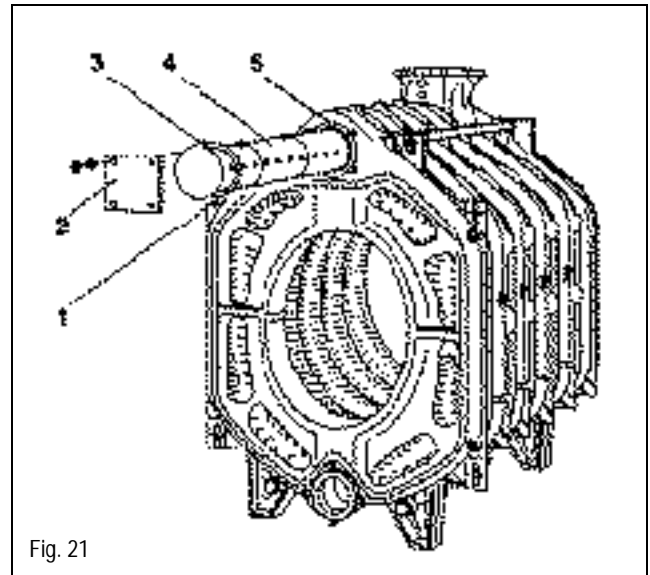

Fig. 21

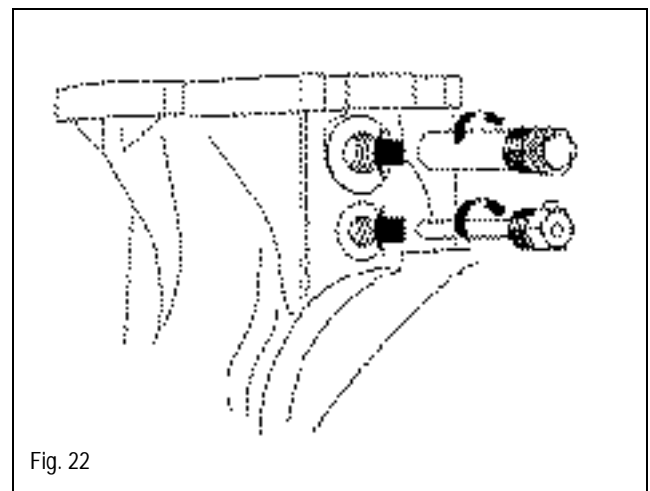

Fig. 22

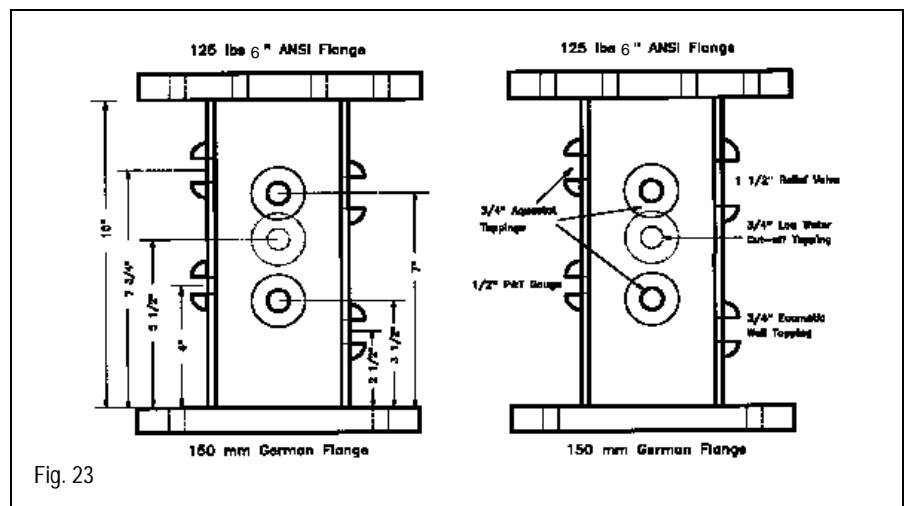

Fig. 23

6 Boiler Assembly

Bottom rear connection: boiler drain installation

- Install gasket and 130 mm blanking flange (1) with $\frac{3}{4}$ " drain connection. (Fig. 24).
- Install $\frac{3}{4}$ " drain.

Top rear connection: boiler return

- Install gasket and 5" return manifold on top rear connection.
- Install washers and nuts and tighten evenly. (Fig. 24).

Bottom front connection: flow blocking pipe installation.

- **First insert the section of blanking tube carrying the spring (L₃) into the bottom nipple port (Fig. 25).**
- Then hook the other sections of blanking pipe (L₂) together as shown in the detail drawing (Fig. 25).
- Finally, insert the section of blanking tube (L₁) carrying the handle.
- Seal off the bottom nipple port with the gasket (3) and blind flange (4).

The number of sections of blanking pipe (L₁, L₂, L₃) which any given boiler will have, and their lengths, can be seen from the table below.

Table 4: Flow Control Elements Arrangement

Elements	615/9	615/10	615/11	615/12	615/13	615/14	615/15	615/16
L1 19"	1			1		1		
L1 25½"		1	1		1		1	1
L2 20"	1	1		2	2			3
L2 26¾"			1			2	2	
L3 17¾"	1	1	1	1	1	1	1	1

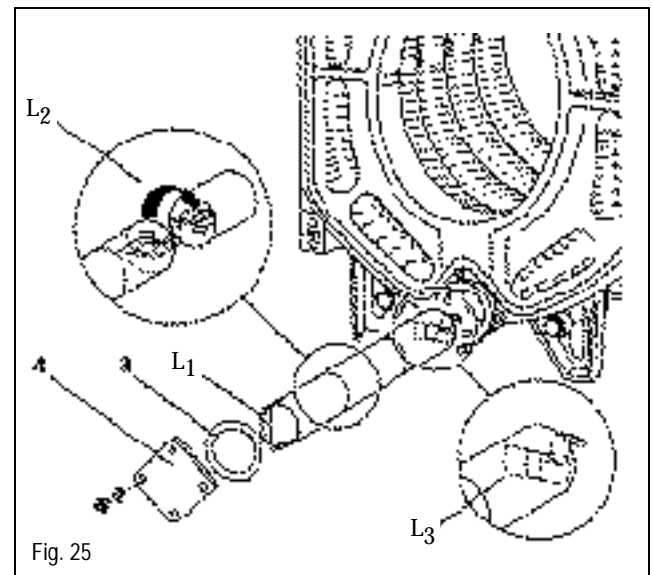
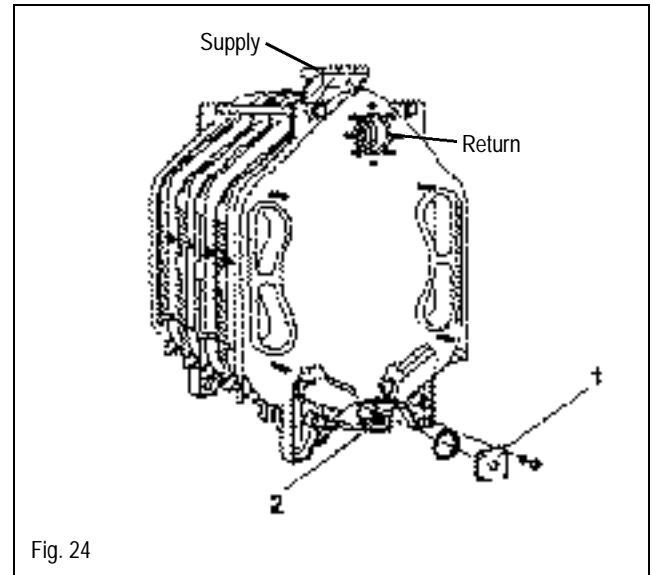

Hydro-static Test

A hydro-static test is only required for boilers assembled on site. The following instructions apply only for knock-down boilers.

- Close off supply return and connections. (Blanking flanges are not provided; use system shut-offs).
- Close off all control tappings.

NOTE: Ensure that during the hydro-static test no pressure sensitive controls are installed on the boiler.

- A pop-off relief valve is recommended on the cold water feed to prevent over-pressurization.
- Install an air vent on the supply manifold.
- Fill the boiler. Vent the boiler at the air vent until water appears. Close the vent and pressurize the boiler.
- The assembled boiler shall be subjected to a hydrostatic test pressure not less than 1 ½ times the maximum allowable working pressure. The maximum test pressure shall not exceed the required test pressure by more than 10 psi.
- If a nipple port connection is leaking, bleed off test pressure, drain water through the fill/drain valve, remove the four tie bars, the return header pipe and flow control elements from the lower front connection.
- Split the boiler at the leaking joint by driving chisels at the top and bottom between the sections (Fig. 26).
- Remove old nipples and clean ports as shown on page 9. Reinstall flue sealing material. Sealing material can be reused. Reassemble per instructions on page 9-12.

NOTE: Always use new push nipples when reassembling the boiler.

- Repeat the hydrostatic test to ensure no leaks.
- Install relief valve after the hydrostatic test.

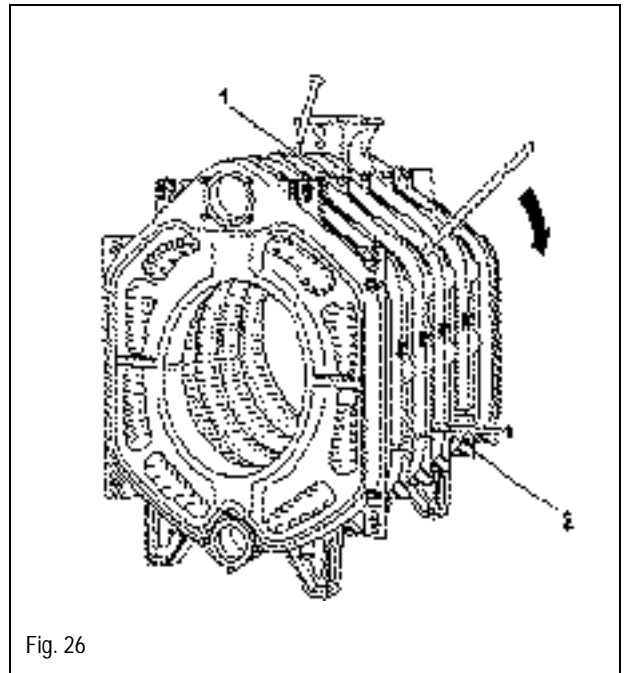

Fig. 26

8 Installation of Boiler Components

Assembly of boiler components: The flue collector, rear clean out covers and burner door are already installed on an assembled block.

Burner Door Installation

- The door hinge supports are factory installed on the right side. Remove to left side for a left swinging door.
- Based on a right swinging door, secure the door hinges on the right side of the front section using 2 M12x50 bolts (Fig. 27). For a left swinging door, mount door hinges on left side of the front section.
- Using “Silastik” glue, secure the GP 18 mm rope in the front section grooves (Fig. 27). The ends must meet on the side in the middle (2).
- Hang the burner door at the hinge supports on the hinges.
- Close burner door and secure with 4 M16x140 burner door bolts. Tighten these bolts crosswise and evenly (Fig. 27).

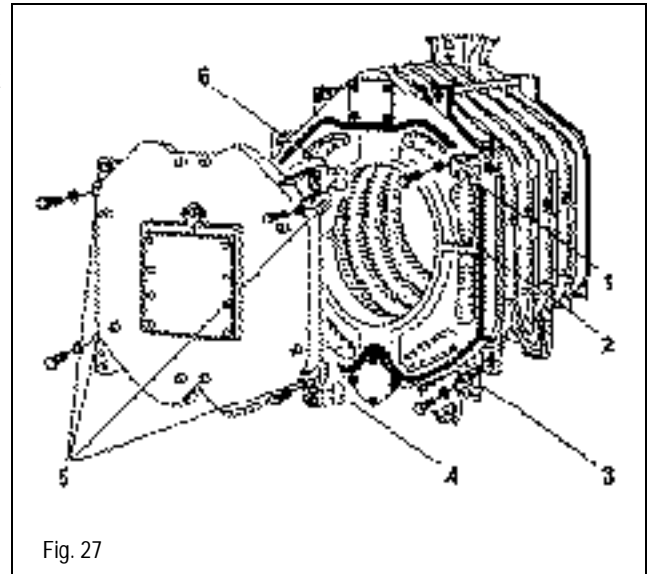

Fig. 27

Flue gas collector installation

- Glue the GP gasket (1,2) (5 ft length) into the flue grooves (5) at the rear section using the “Silastik” labeled tube. (Fig. 28).

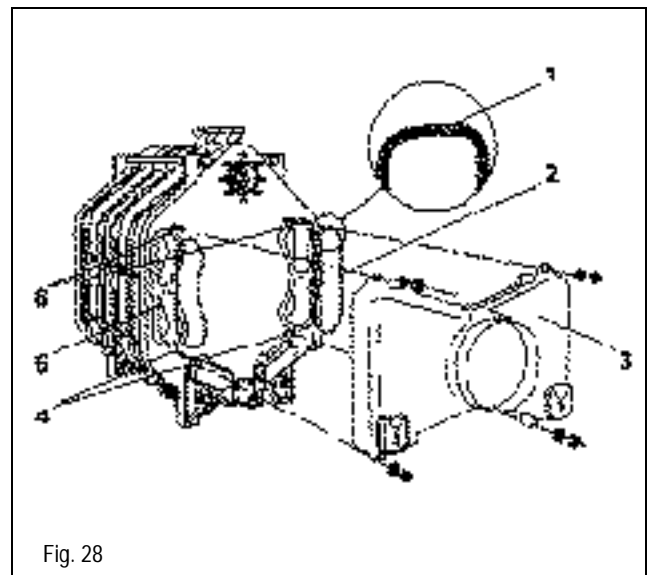

Fig. 28

NOTE: The GP gasket is a silicone coated pliable dry gasket.

- Place the flue collector (3) on the four studs (4,6) located at the rear section and tighten evenly with washers and nuts (Fig. 28).

Installation of rear section clean out covers

- Glue a GP gasket (about 30" long) in the grooves located at the bottom of the rear section (Fig. 29).
- Place clean-out covers (3,4) on studs provided (Fig. 29). Secure evenly with washers and nuts.
- Secure clean-out covers (1,2) on flue collectors (Fig. 29).

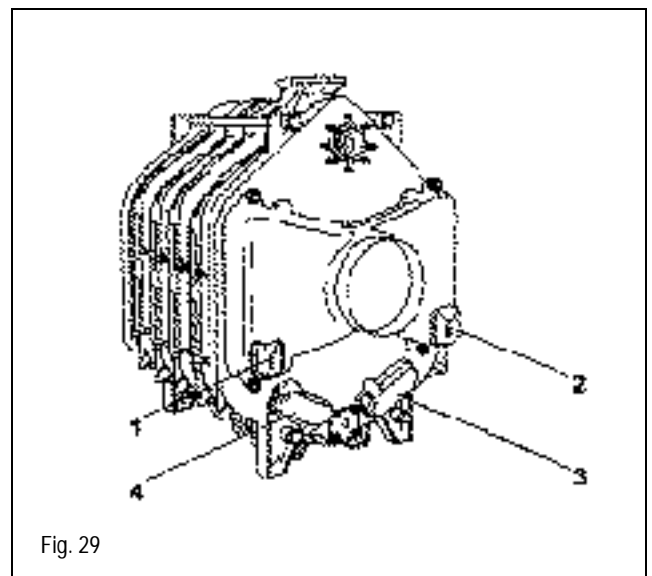

Fig. 29

Flue gas Baffle plates

The G615 boilers have two different styles of flue gas baffle plates. German wording is cast into every baffle. The “Sichel” baffle has a grated profile, the “Wellen” baffle has a curved profile. Install the baffles per schematics shown and per Table 5.

NOTE: The “Sichel” baffle consists of two parts that must be latched together. See Fig. 30 (1) and 31 (1) before latching, and Fig. 32 (2) after latching.

Table 5: Baffle Arrangement

Boiler Model	No. & Baffle Type	No. & Baffle Type	No. & Baffle Type	No. & Baffle Type
	Top Left	Top Right	Bottom Left	Bottom Right
G615/9	2-grated	2-grated	2-grated	2-grated
G615/10	2-grated	2-grated	2-grated	2-grated
G615/11	2-grated	2-grated	2-grated	2-grated
G615/12	1-curved	1-curved	2-grated	2-grated
G615/13	2-grated	2-grated	1-curved	1-curved
G615/14	1-curved	1-curved	1-curved	1-curved
G615/15	0	0	1-curved	1-curved
G615/16	0	0	0	0

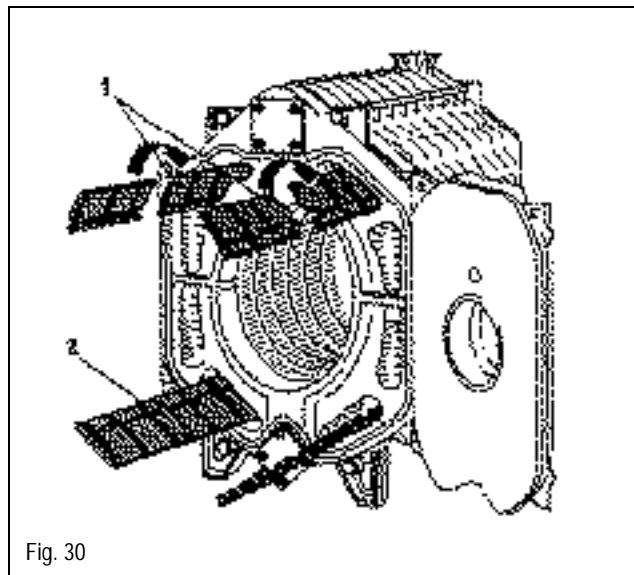

Fig. 30

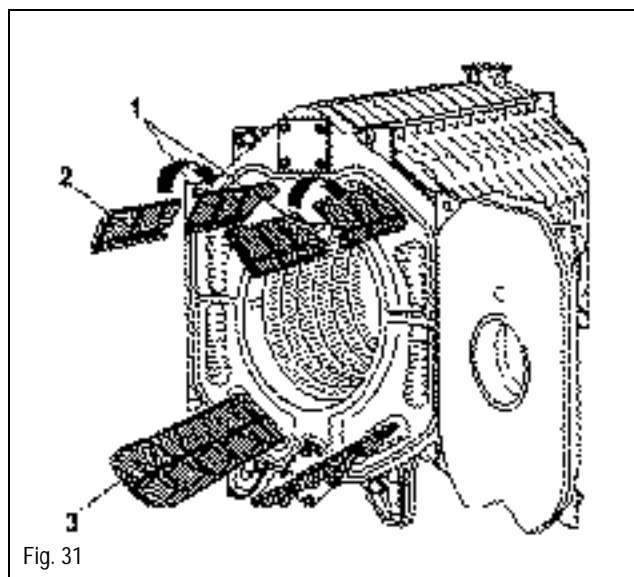

Fig. 31

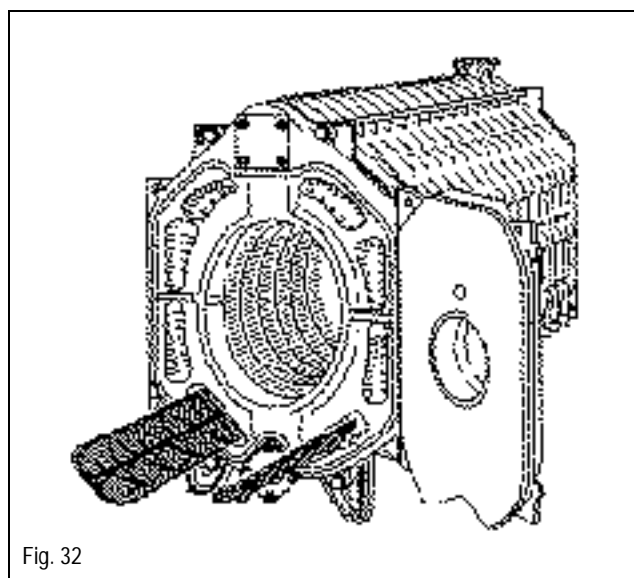

Fig. 32

8 Installation of Boiler Components

- Cut the furnished burner door mounting plate (1) per specifications supplied by burner manufacturer. Burner plate will be cut to specs if burner is purchased through Buderus Hydronic Systems (Fig. 33).
- Secure burner mounting plate to burner door using $\frac{1}{2}$ " diameter dry gasket for sealing.
- Mount burner to burner plate.
- Open burner door. Cut supplied blast tube insulation ring (2) to match the blast tube diameter (Fig. 33).
- Slide the ring (3) around the blast tube (4) to fill out the space between blast tube and burner door insulation.
- Connect the over fire measuring port to a part on the burner, to prevent build-up of contaminants on the sight glass.

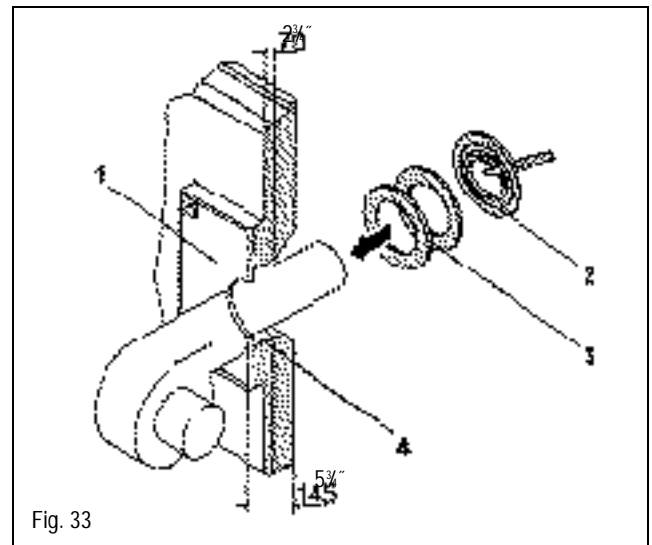

Fig. 33

Flue Collector locking band and flue outlets damper installation

Buderus Hydronic Systems can optionally provide a flue outlet damper.

Buderus Hydronic Systems recommends the use of a flue collector locking band to secure the flue outlet damper to the flue collector.

- Slide the manual flue outlet damper up to the edge step of the flue connection.
- Place the locking band around the stack damper and flue connection (Not Shown).
- Put two clamps over the locking band; one placed over the flue connection, the other placed over the damper. Tighten both clamps.

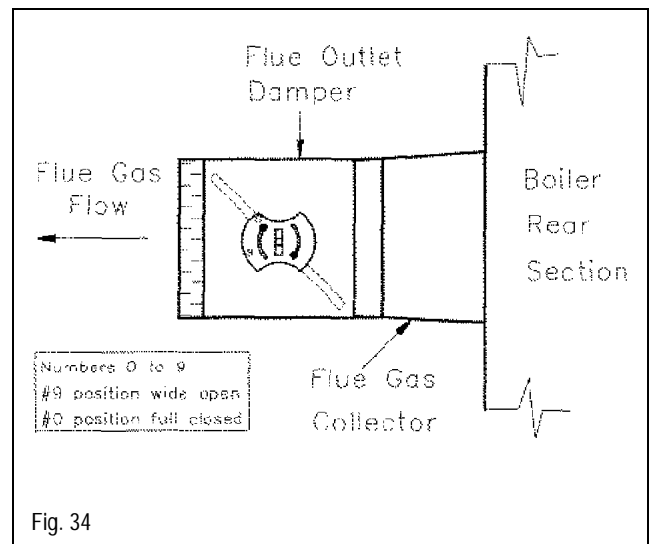

Fig. 34

NOTE: The locking clamps should be snug and evenly secured. Check clamps and retighten them after initial boiler operation.

- During burner start-up procedure, set the flue outlet damper in a fixed position to ensure a +.10 In. W.C. breaching pressure measured before the stack damper. Lock stack damper blade in place (Fig. 34).

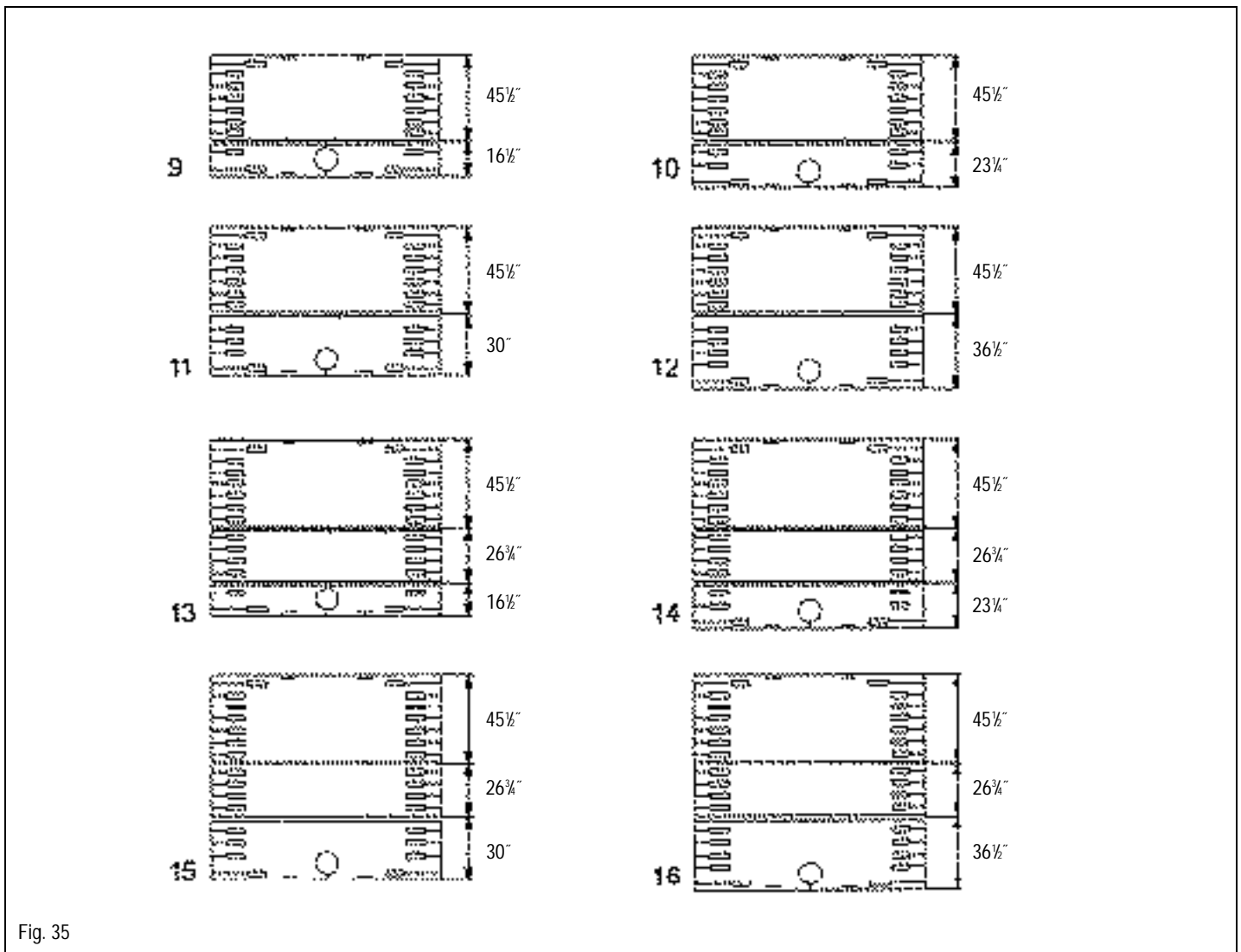

Fig. 35

Insulation blankets

- Install the installation blankets as shown in Figure 35.
- The number next to each sketch corresponds to the number of cast iron sections.
- Push insulation blankets (1) near the bottom of the boiler in between the cast iron legs. The legs fit into the cutouts of the blanket pieces. (Fig. 36)

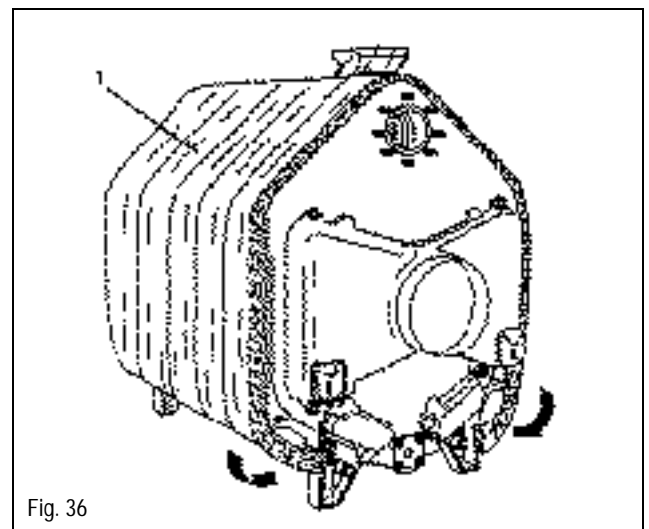
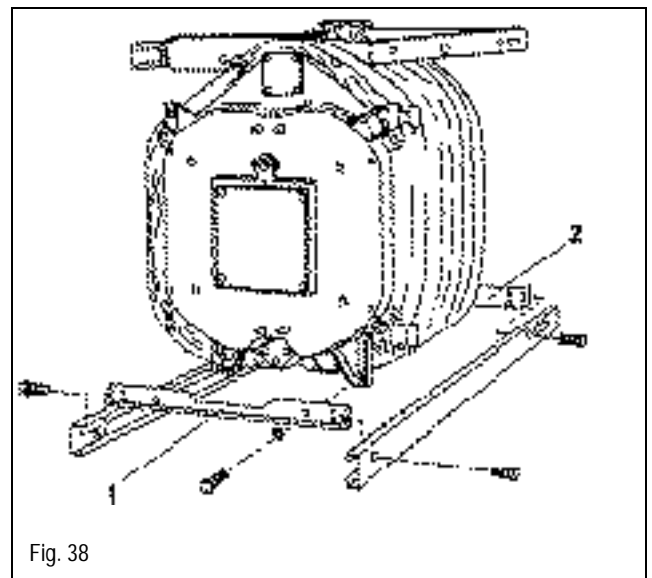
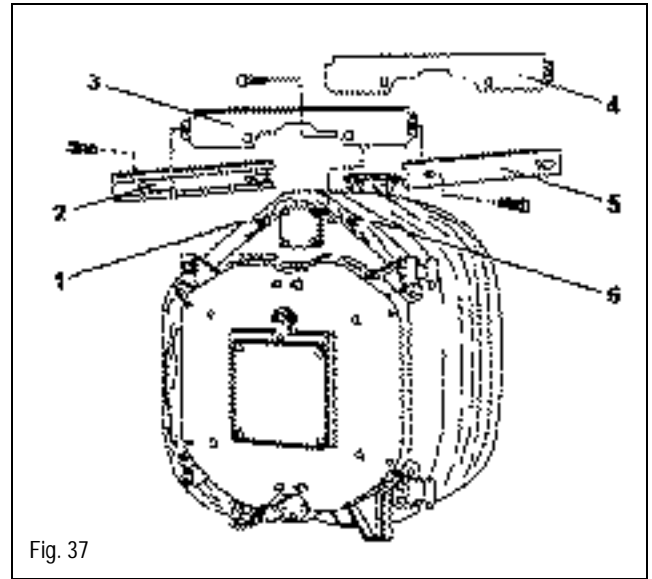

Fig. 36

9 Installation of Insulation & Boiler Jacket Panels

Installation of brackets for mounting of jacket panels

- Place the top front cross bracket (3) on the cast iron (1,6) tabs at the front section and secure with 2 M 8x12 bolts (Fig. 37). The top edge of the bracket must face forward.
- Place the top rear cross bracket (4) on the cast iron tabs at the rear section and secure with 2 M 8x12 bolts (Fig. 37). The top edge of the bracket must face to the rear.
- Place the longitudinal brackets (2,5) from the side on the top cross brackets and secure with sheet metal screws. The slotted openings must be at the rear of the boiler and the edges must point inward .
- Secure the bottom cross bracket (1) with M 8x12 bolts to front section legs (Fig. 38)
- Secure the bottom rear cross bracket (2) with M 8x12 bolts to rear section legs (Fig. 38).



- Place the longitudinal brackets (4,5) from the side on the bottom cross brackets and secure with sheet metal screws. Slotted openings must be at the rear of the boiler and the edges must point inward. (Fig. 39).
- Slide rear insulation piece (2) with the cut-out for the return connection pointed upward on the flue collector (Fig. 39).
- Attach this insulation with 2 springs to top cross bracket (1). (Fig. 39).
- Close the slit of the insulation below flue collector with 2 springs (3) (Fig. 39).
- Use 2 springs on each side to secure this insulation to insulation blanket (Fig. 39).

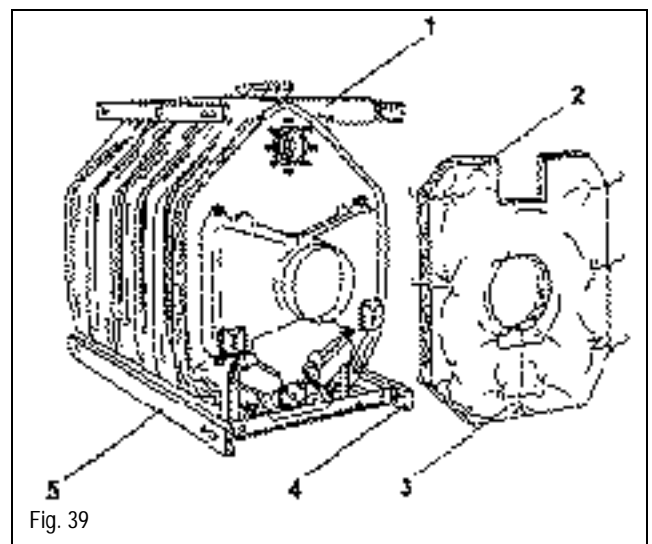

- Slide the top front insulation piece (1) on the top front cross bracket (Fig. 40).
- Support this piece with 3 springs (2) to insulation blanket (Fig. 40).
- Install bottom front cover (3) between the longitudinal brackets and secure with screws. (Fig. 41).
- Install bottom rear cover in similar manner.

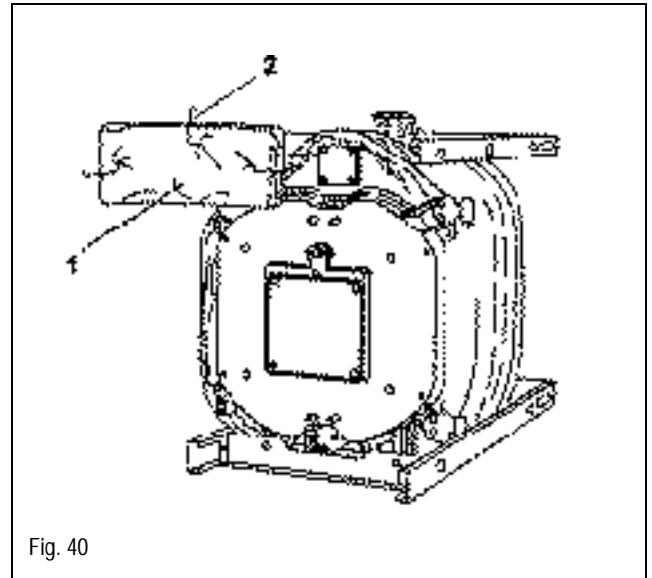

Fig. 40

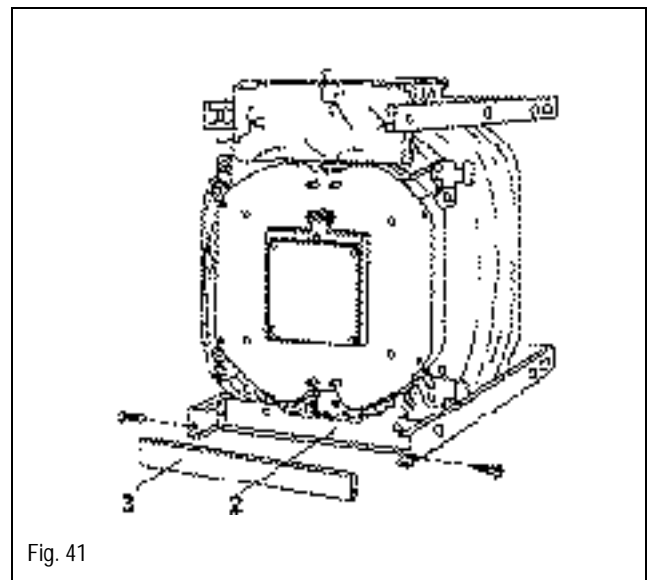

Fig. 41

Installation of jacket panels

- Install all side and top panels according to Fig. 46.
- Install side panels from front to back.
- Put bottom edge of first side panel (1) behind lower longitudinal bracket (3). Lift panel slightly and engage the tabs near the top edge of the panel in the slots of the top longitudinal bracket (2). (Fig. 42).

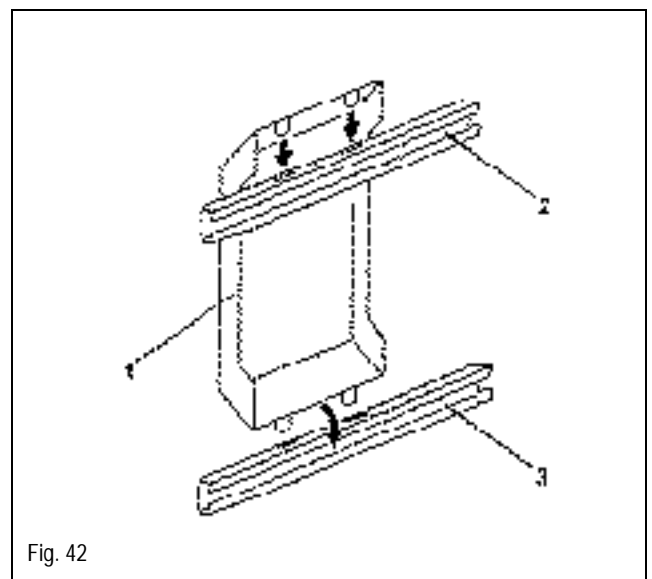
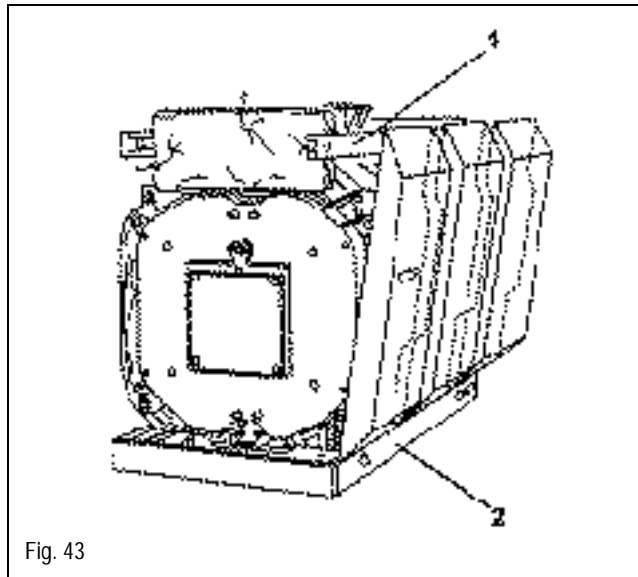

Fig. 42

9 Installation of Insulation & Boiler Jacket Panels

- Install remaining panels in similar fashion. (Fig. 43).



- Engage the lower tabs (1) of front top panel (with knockouts for mounting of Logamatic control) into the top front slots (2) of the upper longitudinal brackets. (Fig. 44).
- Slide top cover forward and secure rear side with 2 sheet metal screws to the side panels. (Fig. 44).

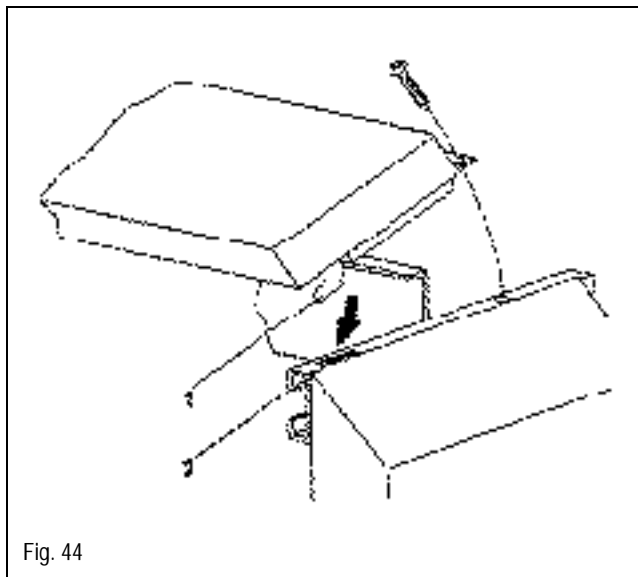

- Slide a 16" wide top (2) next with the edge forward under the first top panel (1). (Fig. 45).

NOTE: In case a Buderus control panel is installed on the boiler, route the boiler sensor and capillaries on top of the insulation to the supply manifold. Refer to the Logamatic manuals for additional details.

- Refer to Figure 46 for proper sequence of remaining top panels. Place the rear so that the cut-out of the panel engages the rear cross bracket.

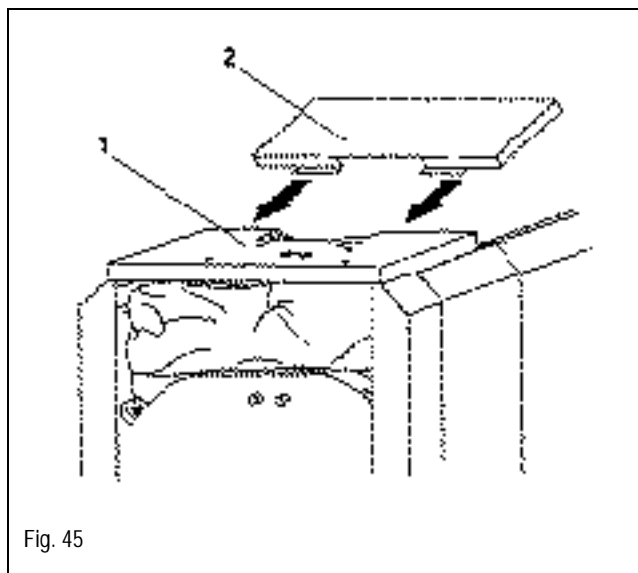

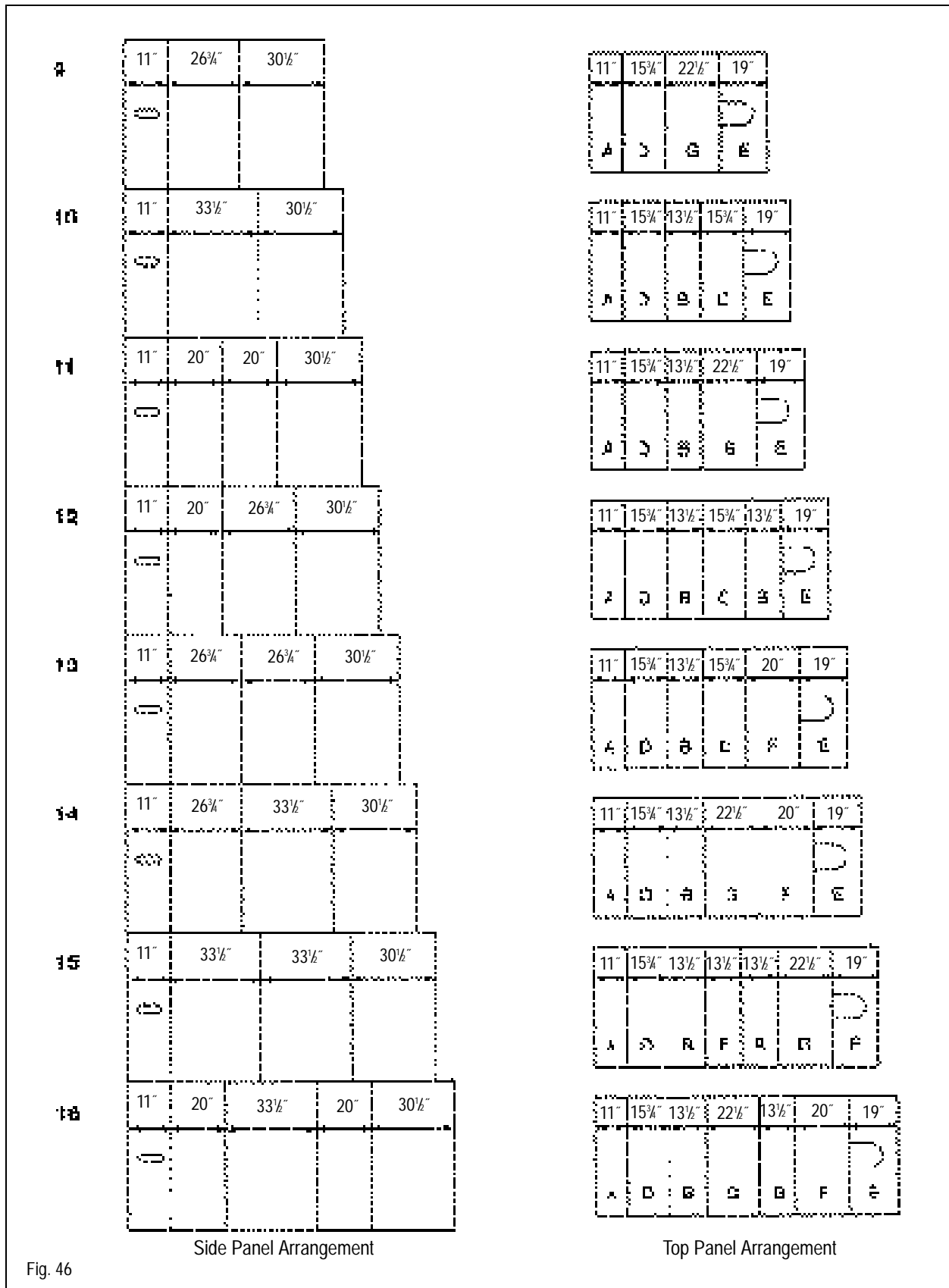

10 Installation of Insulation and Jacket Components

- Secure the top rear panel (1) with sheet metal screws to the rear top panel and side panels.(Fig. 47).
- Secure bottom rear panel 2 with the cut-out for boiler drain pointed down with sheet metal screws to side panels (Fig. 47).

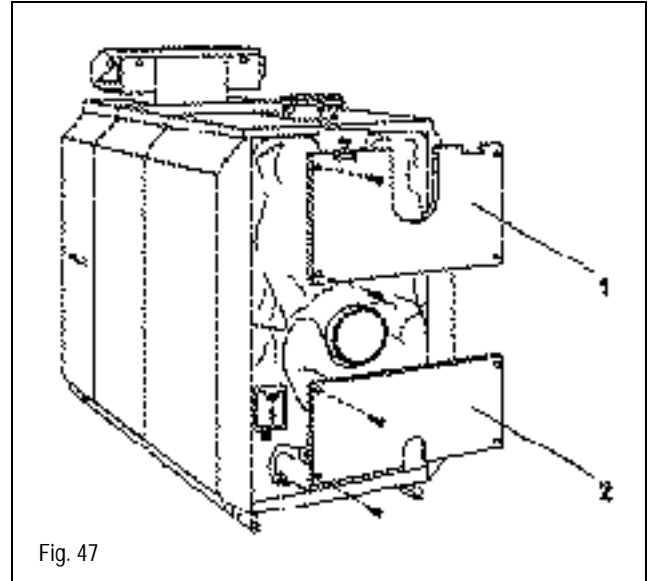

- Secure left and right hand front panels with 4 M 8 x 12 screws each to cast iron support points located on burner door (Fig. 48)
- Hang the burner door panel cover (2) in front panel knock-outs (Fig. 48).
- Attach the boiler rating plate to left or right side of the boiler jacket.
- Close off the four openings in the front panels with sealing plugs (1,3). (Fig. 48).

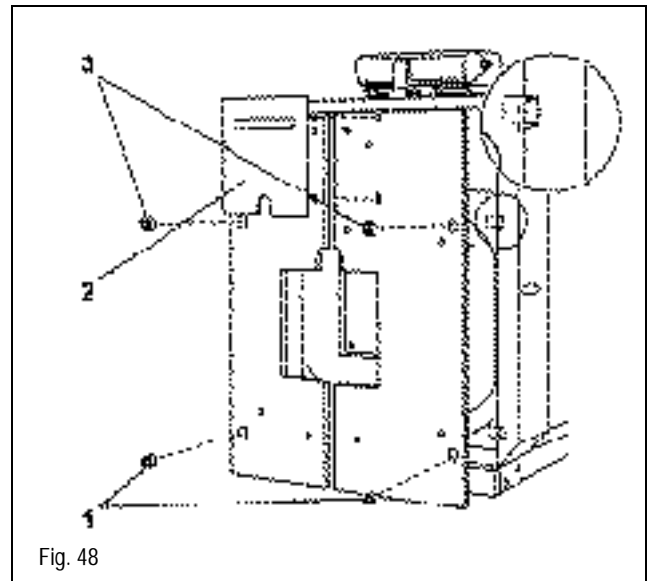

NOTE: The burner door bolts are visible after removal of these plugs. The first front side panel (with the hand opening) must be removed before the burner door can be opened.

Buderus Control Panel

Installation of a Buderus control panel.

- Remove 2 top screws from control panel housing (1). (Fig. 49).
- Mount control on top of boiler by engaging bottom front tabs (4,5) into oval knock-outs. Pull control forward, press down on rear part of control and snap plastic hooks (2) in the rear into square knock-outs (3,7). (Fig. 49).
- Secure control panel with 2 screws to top of jacket panel (Fig.50).
- Unroll boiler sensor bundle carefully and route on top of insulation to Logamatic well placed in supply connection.
- Place Logamatic well into $\frac{3}{8}$ " tapping (1) in boiler supply connection.
- Refer to control panel manuals for wiring instructions.

NOTE: Install all electrical wiring per local code.

- Use plastic strain reliefs (4) to secure wiring to Logamatic by pushing plastic tabs over (Fig. 50). Install top housing with 2 screws.
- Lock sensor bundle in place with metal clip (2)(Fig. 51)
Do NOT kink capillaries!

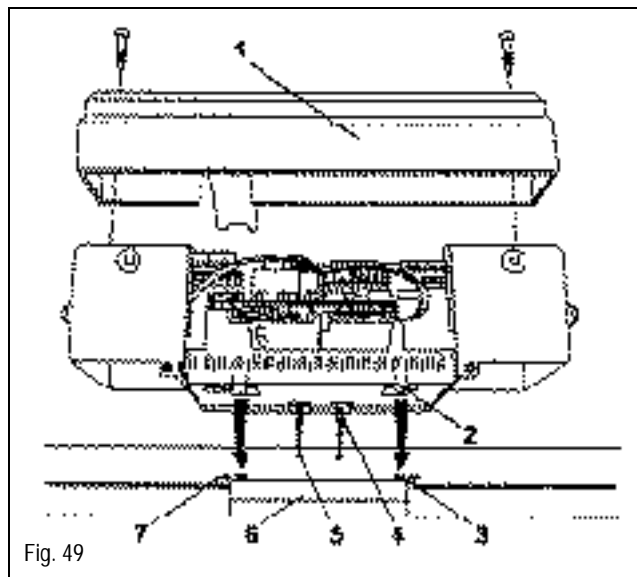

Fig. 49

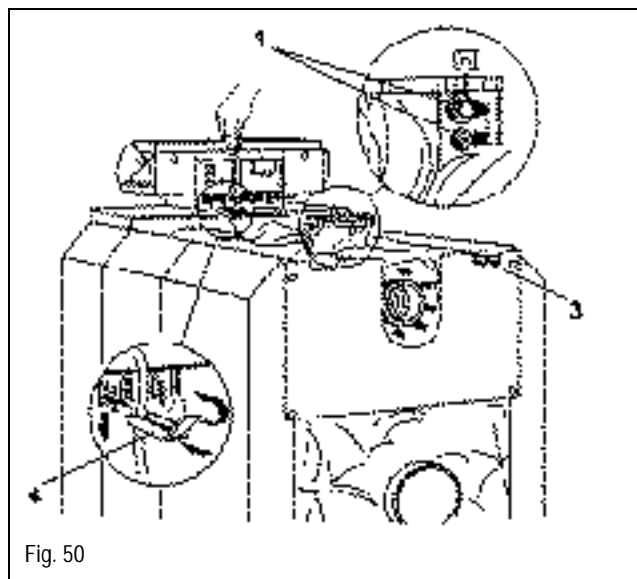

Fig. 50

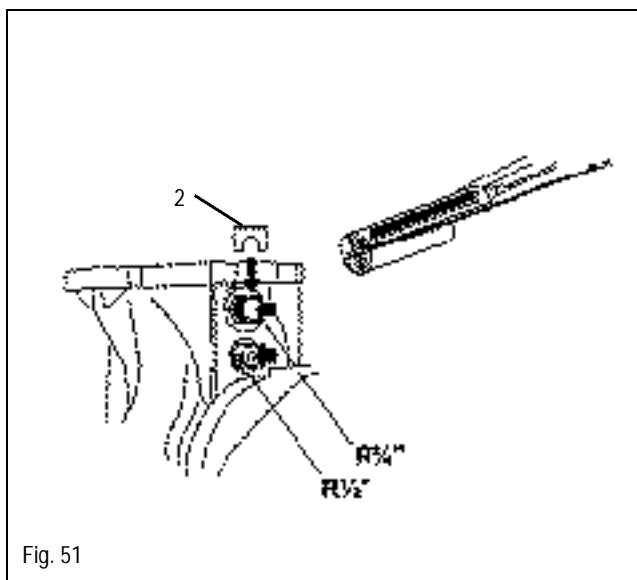

Fig. 51

11 Maintenance Instructions

Important for maximum fuel efficiency:

- Burner operation should be monitored on a regular basis. Pay particular attention to combustion efficiency, CO₂ level and ensure soot-free operation.
- Clean the heat exchanger on an annual basis. Cleaning brushes are available from Buderus Hydronic Systems, Inc.
- We strongly recommend a service contract with your heating contractor, fuel supplier or burner service company to ensure long term, trouble-free and efficient operation.

Boiler cleaning with brushes

- Disconnect electricity. (Disconnect main system switch and padlock open to prevent burner from being energized during service).
- Disconnect the fuel supply and electrical wires to the burner.
- Lift up at the hand holes the front left and right side panels (1,2) slightly and remove (Fig. 52).

NOTE: The burner door front panels (4) do not need to be removed.

- Remove plastic covers from the four burner door bolts.
- Remove burner door bolts (3,5) and open burner door (Fig 52).

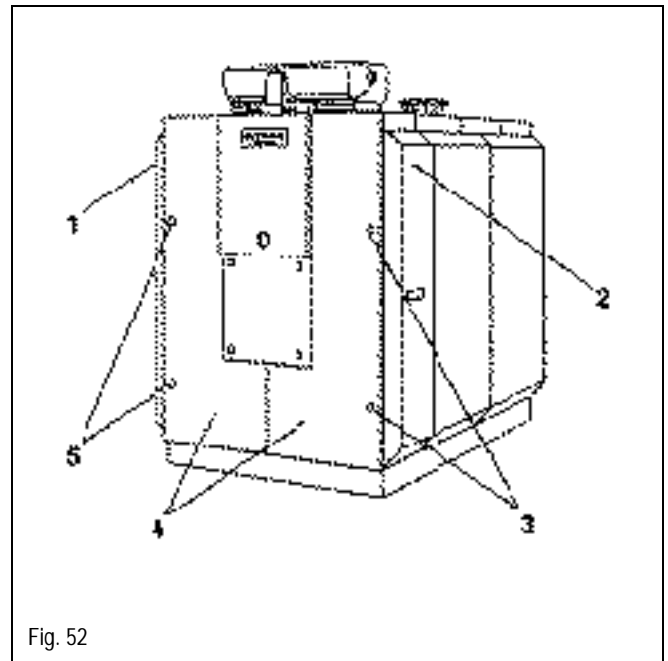

Fig. 52

- Remove all baffles (1-4) (if present) from the heat exchanger. Record where each baffle was located (Fig. 53).

NOTE: The G615/16 does not have baffle plates. Refer to Table 5 on page 19 for details.

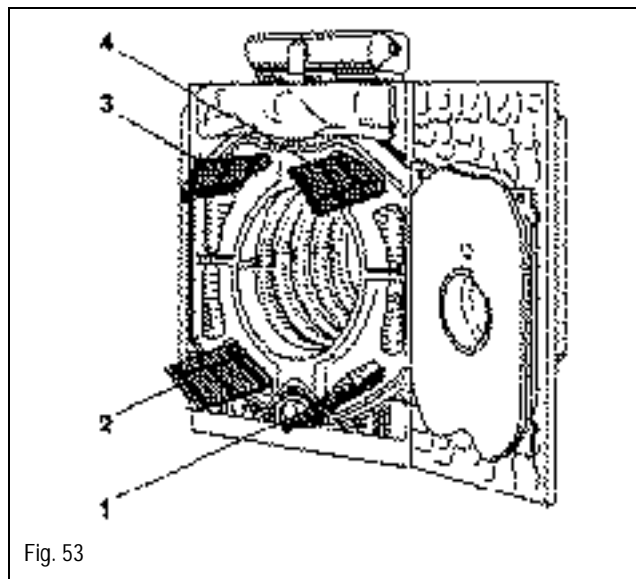

Fig. 53

- Remove bottom rear panel to gain access to rear clean-out covers (Fig. 54).
- Remove springs underneath flue collector from insulation, flap insulation pieces (1,2) up and secure temporarily with these springs to upper insulation.
- Remove clean-out covers (3) from the rear section and flue collector (Fig. 54).

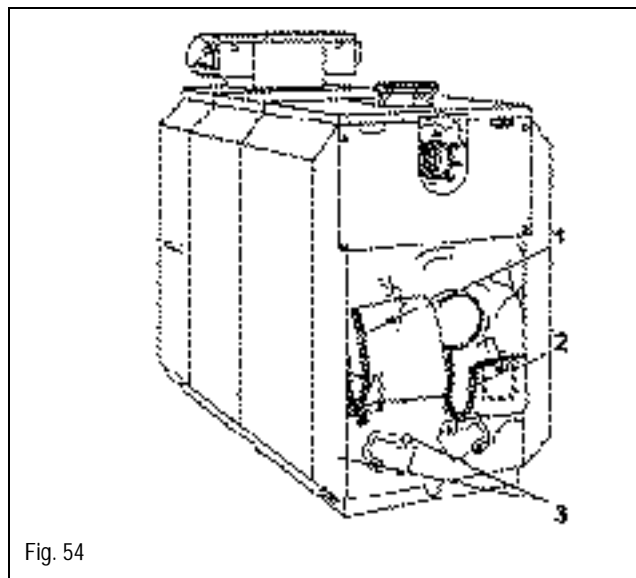

Fig. 54

- Refer to Figure 55 and the table below for cleaning brush selection.

Boiler Model	Brush No.	Brush Size	Application Area	Handle Selection	Length of Handles
G615/9-11	4	ø3" x 4 1/4"	2nd+3rd Pass	A+K	80"
	5	ø2 1/4" x 3"	2nd+3rd Pass		
	8	ø8" x 3"	Main Chamber		
G615/12-14	4	ø3" x 4 1/4"	2nd+3rd Pass	A+K	100"
	5	ø2 1/4" x 3"	2nd+3rd Pass		
	8	ø8" x 3"	Main Chamber		
G615/15-16	4	ø3" x 4 1/4"	2nd+3rd Pass	A+K	40" + 80"
	5	ø2 1/4" x 3"	2nd+3rd Pass		
	8	ø8" x 3"	Main Chamber		

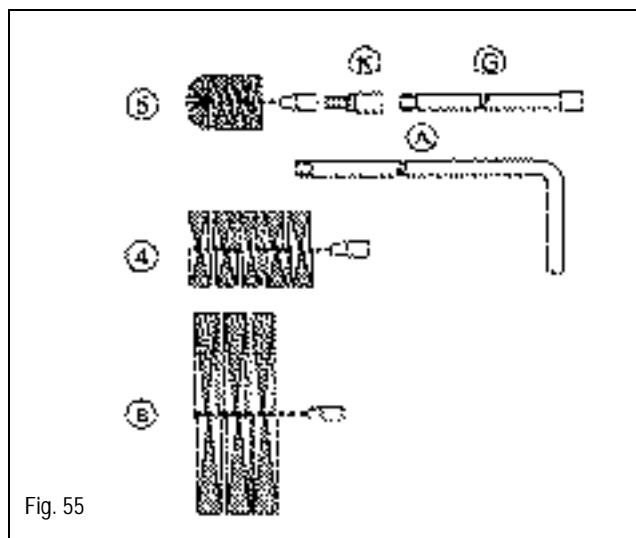

Fig. 55

11 Maintenance Instructions

- Use brush No.'s 4 and 5 to brush all secondary and tertiary flue passages (1,3) (Fig. 56).
- Brush the main combustion chamber (2) with brush No.8 (Fig. 56).
- Remove combustion by-products from the front and from the flue gas collector (Fig. 54 and 56).
- Clean the lower flue passages from the front with brushes No.'s 4 and 5 (Fig. 56).
- Remove combustion by-products from all flue passages and main combustion chamber.
- Check all pliable sealing ropes. If a rope is damaged or brittle, replace it.
- Clean baffle plates with brushes.
- Insert baffle plates. Refer to Table 5 page 19 for proper placement.
- Reinstall clean-out covers and close burner door. Tighten bolts evenly. Remount jacket panels and screw in place.
- Put rear insulation piece back in place and pull together under flue collector with springs (1) (Fig. 57).

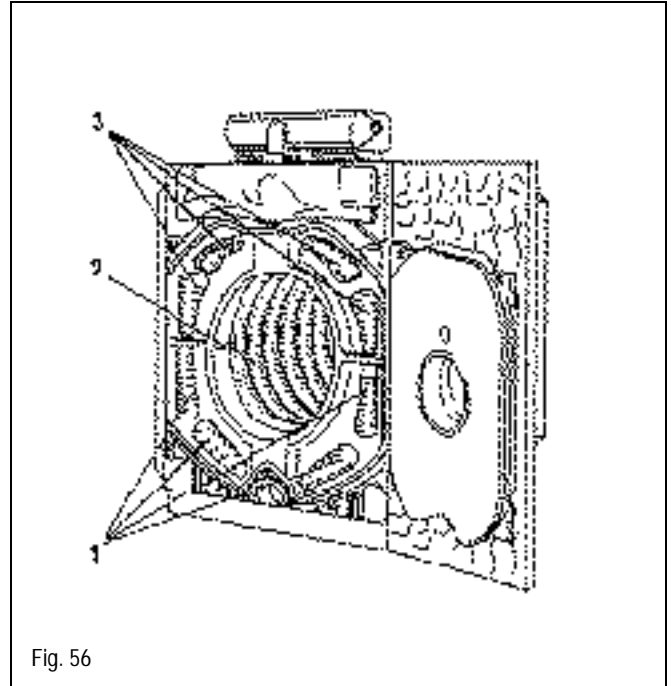

Fig. 56

Wet cleaning procedure

- Follow the above procedure for accessing the boiler to perform a wet cleaning of the boiler. Follow cleaning agent instructions.

Water level control

- Maintain system water pressure within the required levels.
- Verify system water level; add water and vent as needed. Automatically add water to system and vent during operation. Determine and correct problem if continuous make-up water must be added to the system.

NOTE: Continuous make-up water indicates a leak in the system. This causes corrosive damage to all system components and must be solved immediately.

Warranty voided if problem is not corrected.

Fill and make-up water requirements

- Fill and make-up water must comply with the requirements listed on page 5.
- Additional information is supplied on the enclosed "Water Preparations Requirements" sheet.

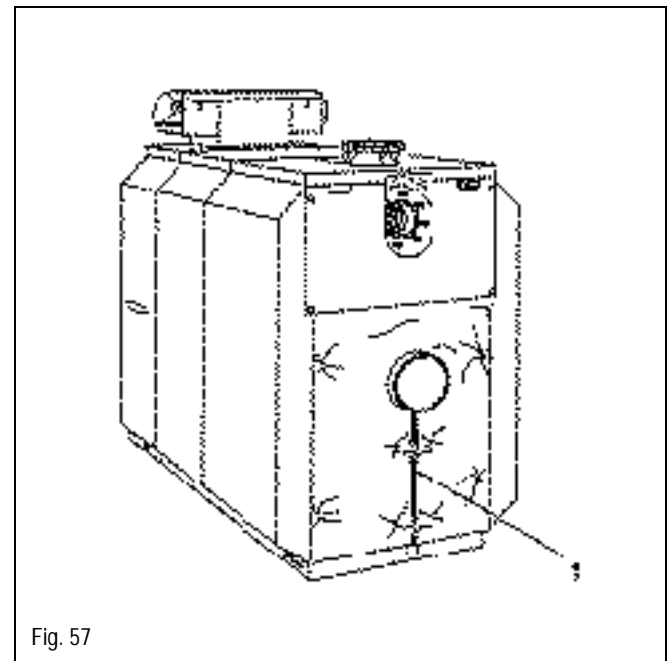
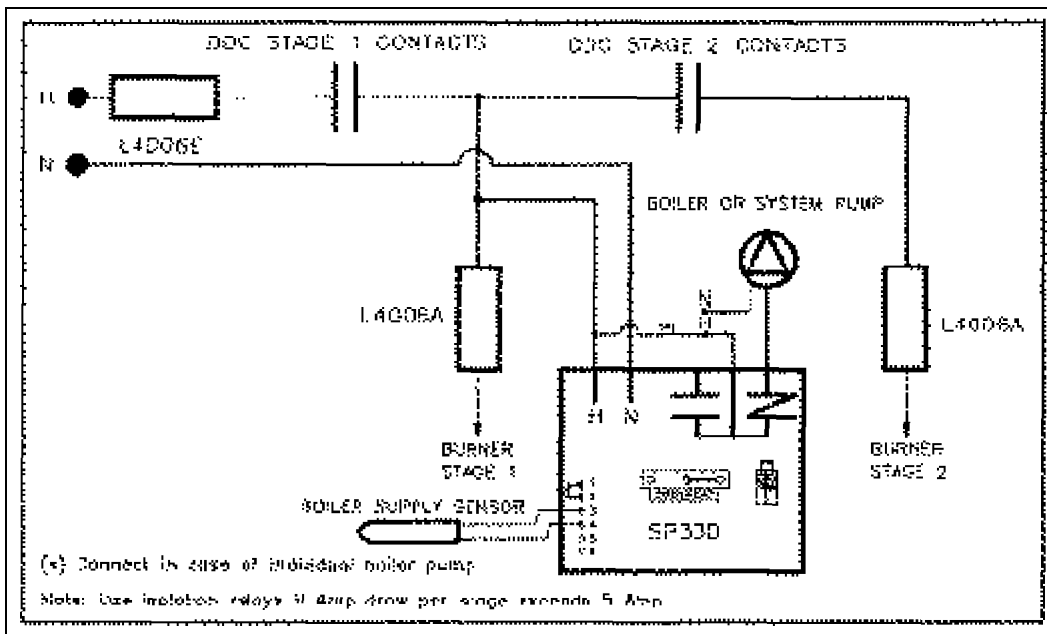

Fig. 57

Supply temperature control

An “Open-On-Rise” aquastat is required to interrupt water circulation through the boiler to prevent the supply temperature from dropping below 122°F during burner operation. The aquastat is to temporarily stop operation of the main system pump (or individual boiler pumps in case of a multiple boiler installation).

Refer to Figure 58 for a typical control schematic for a single boiler with supply temperature control. Control components can be furnished by Buderus Hydronic Systems, Inc.



13 Shipping Component Breakdown

Component Reference List for G615 Boilers

Boiler Model	Part Number	/9	/10	/11	/12	/13	/14	/15	/16
Item:	63170020	1	1	1	1	1	1	1	1
Standard Pallet (Front, Rear, supply, sections & door)									
Midsections (3)	5189870	2	1	2	3	2	3	4	3
Midsections (2)	5189869	0	2	1	0	2	1	0	2
Base unit box G615/9-16	63130018	1	1	1	1	1	1	1	1
Assembly Box (Model specific)		63130070	63130072	63130074	63130076	63130078	63130080	63130082	63130084
Jacket Assembly Parts (Model specific)		5621912-1	5621914-1	5621916-1	5621918-1	5621920-1	5621922-1	5621924-1	5621926-1
Jacket Pack A	5932787	1	1	1	1	1	1	1	1
Jacket Pack B (Model specific)		5932770-1	5932772-1	5932774-1	5932776-1	5932778-1	5932780-1	5932782-1	5932784-1
Tie Bars (Model specific)		5128120-1	5128122-1	5128124-1	5128126-1	5128128-1	5128130-1	5128132-1	5128134-1
Insulation (Model specific)		63240092	63240094	63240096	63240098	63240092 5932818	63240094 5932818	63240096 5932818	63240098 5932818
6" manifold, 6" flange & controls		1	1	1	1	1	1	1	1

Heating Contractor:

PRODUCTS MANUFACTURED BY

BBT Thermotechnik GmbH
35573 Wetzlar
www.buderus.de

Buderus

BBT North America Corporation
50 Wentworth Avenue
Londonderry, NH 03053
Tel: 603-552-1100 • Fax: 603-584-1681
www.buderus.net

*BBT North America Corporation reserves the right to make changes without notice
due to continuing engineering and technological advances.*